



Operation and Maintenance Manual

335F Excavator

KNE 1-UP (335F L)
SGJ 1-UP (335F L)
FEP 1-UP (335F L)

Language: Original Instructions

Important Safety Information

Most accidents that involve product operation, maintenance and repair are caused by failure to observe basic safety rules or precautions. An accident can often be avoided by recognizing potentially hazardous situations before an accident occurs. A person must be alert to potential hazards, including human factors that can affect safety. This person should also have the necessary training, skills and tools to perform these functions properly.

Improper operation, lubrication, maintenance or repair of this product can be dangerous and could result in injury or death.

Do not operate or perform any lubrication, maintenance or repair on this product, until you verify that you are authorized to perform this work, and have read and understood the operation, lubrication, maintenance and repair information.

Safety precautions and warnings are provided in this manual and on the product. If these hazard warnings are not heeded, bodily injury or death could occur to you or to other persons.

The hazards are identified by the "Safety Alert Symbol" and followed by a "Signal Word" such as "DANGER", "WARNING" or "CAUTION". The Safety Alert "WARNING" label is shown below.



The meaning of this safety alert symbol is as follows:

Attention! Become Alert! Your Safety is Involved.

The message that appears under the warning explains the hazard and can be either written or pictorially presented.

A non-exhaustive list of operations that may cause product damage are identified by "NOTICE" labels on the product and in this publication.

Caterpillar cannot anticipate every possible circumstance that might involve a potential hazard. The warnings in this publication and on the product are, therefore, not all inclusive. You must not use this product in any manner different from that considered by this manual without first satisfying yourself that you have considered all safety rules and precautions applicable to the operation of the product in the location of use, including site-specific rules and precautions applicable to the worksite. If a tool, procedure, work method or operating technique that is not specifically recommended by Caterpillar is used, you must satisfy yourself that it is safe for you and for others. You should also ensure that you are authorized to perform this work, and that the product will not be damaged or become unsafe by the operation, lubrication, maintenance or repair procedures that you intend to use.

The information, specifications, and illustrations in this publication are on the basis of information that was available at the time that the publication was written. The specifications, torques, pressures, measurements, adjustments, illustrations, and other items can change at any time. These changes can affect the service that is given to the product. Obtain the complete and most current information before you start any job. Cat dealers have the most current information available.



When replacement parts are required for this product Caterpillar recommends using Cat replacement parts.

Failure to follow this warning may lead to premature failures, product damage, personal injury or death.

In the United States, the maintenance, replacement, or repair of the emission control devices and systems may be performed by any repair establishment or individual of the owner's choosing.

Table of Contents

Foreword	5	Sound Information and Vibration Information .	42
Safety Section		Operator Station	45
Safety Messages	7	Guards (Operator Protection)	45
Additional Messages	18	Product Information Section	
General Hazard Information.....	25	General Information	47
Crushing Prevention and Cutting Prevention..	27	Identification Information.....	96
Burn Prevention.....	28	Operation Section	
Fire Prevention and Explosion Prevention.....	29	Before Operation	99
Fire Safety	32	Machine Operation	101
Fire Extinguisher Location.....	33	Engine Starting.....	164
Track Information	33	Operation.....	167
Electrical Storm Injury Prevention	33	Operating Techniques	172
Before Starting Engine	33	Parking	203
Visibility Information	33	Transportation Information	207
Restricted Visibility	34	Towing Information	214
Engine Starting.....	36	Engine Starting (Alternate Methods).....	217
Before Operation.....	36	Maintenance Section	
Work Tools.....	36	Maintenance Access	220
Operation.....	37	Lubricant Viscosities and Refill Capacities ...	222
Engine Stopping	40	Maintenance Support	232
Lifting Objects.....	40	Maintenance Interval Schedule.....	239
Demolition	40	Warranty Section	
Parking	41	Warranty Information.....	323
Slope Operation	41	Reference Information Section	
Equipment Lowering with Engine Stopped	42	Reference Materials	324
		Index Section	

Index..... 325

Foreword

California Proposition 65 Warning

Diesel engine exhaust and some of its constituents are known to the State of California to cause cancer, birth defects, and other reproductive harm.



WARNING – This product can expose you to chemicals including ethylene glycol, which is known to the State of California to cause birth defects or other reproductive harm. For more information go to:

www.P65Warnings.ca.gov

Do not ingest this chemical. Wash hands after handling to avoid incidental ingestion.



WARNING – This product can expose you to chemicals including lead and lead compounds, which are known to the State of California to cause cancer, birth defects, or other reproductive harm. For more information go to:

www.P65Warnings.ca.gov

Wash hands after handling components that may contain lead.

Literature Information

This manual should be stored in the operator's compartment in the literature holder or seat back literature storage area.

This manual contains safety information, operation instructions, transportation information, lubrication information, and maintenance information.

Some photographs or illustrations in this publication show details or attachments that can be different from your machine. Guards and covers might have been removed for illustrative purposes.

Continuing improvement and advancement of product design might have caused changes to your machine which are not included in this publication. Read, study, and keep this manual with the machine.

Whenever a question arises regarding your machine, or this publication, please consult your Cat dealer for the latest available information.

Safety

The safety section lists basic safety precautions. In addition, this section identifies the text and locations of warning signs and labels used on the machine.

Read and understand the basic precautions listed in the safety section before operating or performing lubrication, maintenance, and repair on this machine.

Operation

The operation section is a reference for the new operator and a refresher for the experienced operator. This section includes a discussion of gauges, switches, machine controls, attachment controls, transportation, and towing information.

Photographs and illustrations guide the operator through correct procedures of checking, starting, operating, and stopping the machine.

Operating techniques outlined in this publication are basic. Skill and techniques develop as the operator gains knowledge of the machine and its capabilities.

Maintenance

The maintenance section is a guide to equipment care. The Maintenance Interval Schedule (MIS) lists the items to be maintained at a specific service interval. Items without specific intervals are listed under the "When Required" service interval. The Maintenance Interval Schedule lists the page number for the step-by-step instructions required to accomplish the scheduled maintenance. Use the Maintenance Interval Schedule as an index or "one safe source" for all maintenance procedures.

Maintenance Intervals

Use the service hour meter to determine servicing intervals. Calendar intervals shown (daily, weekly, monthly, etc.) can be used instead of service hour meter intervals if the calendar intervals provide more convenient servicing schedules and approximate the indicated service hour meter reading. Perform the recommended service at the interval that occurs first.

Under severe, dusty, or wet operating conditions, more frequent lubrication than is specified in the maintenance intervals chart might be necessary.

Perform service on items at multiples of the original requirement. For example, at every 500 service hours or 3 months, also service those items listed under every 250 service hours or monthly and every 10 service hours or daily.

Certified Engine Maintenance

Proper maintenance and repair are essential to keep the engine and machine systems operating correctly. As the heavy-duty off-road diesel engine owner, you are responsible for the performance of the required maintenance listed in the Owner Manual, Operation and Maintenance Manual, and Service Manual.

It is prohibited for any person engaged in the business of repairing, servicing, selling, leasing, or trading engines or machines to remove, alter, or to render inoperative, any emission-related device or element of design installed on or in an engine or machine that is in compliance with all applicable regulations of the intended country to which it has been shipped. Certain elements of the machine and engine such as the exhaust system, fuel system, electrical system, intake air system, and cooling system may be emission-related and should not be altered unless approved by Caterpillar.

Machine Capacity

Additional attachments or modifications may exceed machine design capacity which can adversely affect performance characteristics. Included would be stability and system certifications such as brakes, steering, and rollover protective structures (ROPS). Contact your Cat dealer for further information.

Product Identification Number

Effective First Quarter 2001 the Product Identification Number (PIN) has changed from 8 to 17 characters. To provide uniform equipment identification, construction equipment manufacturers are moving to comply with the latest version of the product identification numbering standard. Non-road machine PINs are defined by ISO 10261. The new PIN format will apply to all machines and generator sets. The PIN plates and frame marking will display the 17 character PIN. The new format will look like the following:

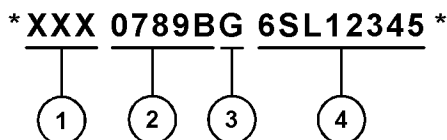

Illustration 1

g03891925

Where:

1. World Manufacturing Code (characters 1-3)

2. Machine Descriptor (characters 4-8)

3. Check Character (character 9)

4. Machine Indicator Section (MIS) or Product Sequence Number (characters 10-17). These were previously referred to as the Serial Number.

Machines and generator sets produced before First Quarter 2001 will maintain their 8 character PIN format.

Components such as engines, transmissions, axles, and work tools will continue to use an 8 character Serial Number (S/N).

Safety Section

i05967681

Safety Messages

SMCS Code: 7000; 7405

There are several specific safety messages on this machine. The exact location of the hazards and the description of the hazards are reviewed in this section. Please become familiarized with all safety messages.

Make sure that all of the safety messages are legible. Clean the safety messages or replace the safety messages if you cannot read the words. Replace the illustrations if the illustrations are not visible. When you clean the safety messages, use a cloth, water, and soap. Do not use solvent, gasoline, or other harsh chemicals to clean the safety messages. Solvents, gasoline, or harsh chemicals could loosen the adhesive that secures the safety message. Loose adhesive will allow the safety message to fall.

Replace any safety message that is damaged, or missing. If a safety message is attached to a part that is replaced, install a safety message on the replacement part. Any Caterpillar dealer can provide new safety messages.

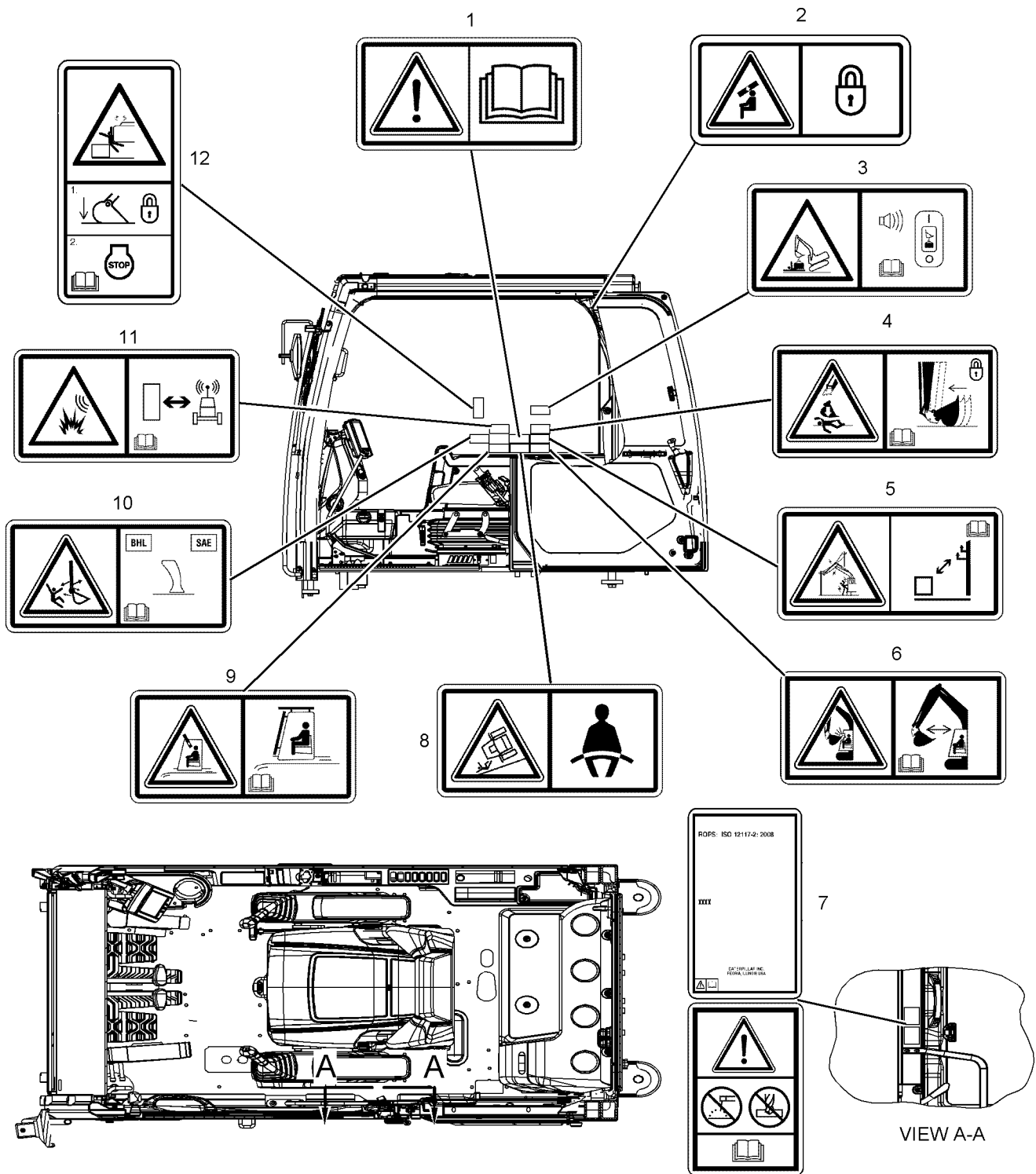

Illustration 2

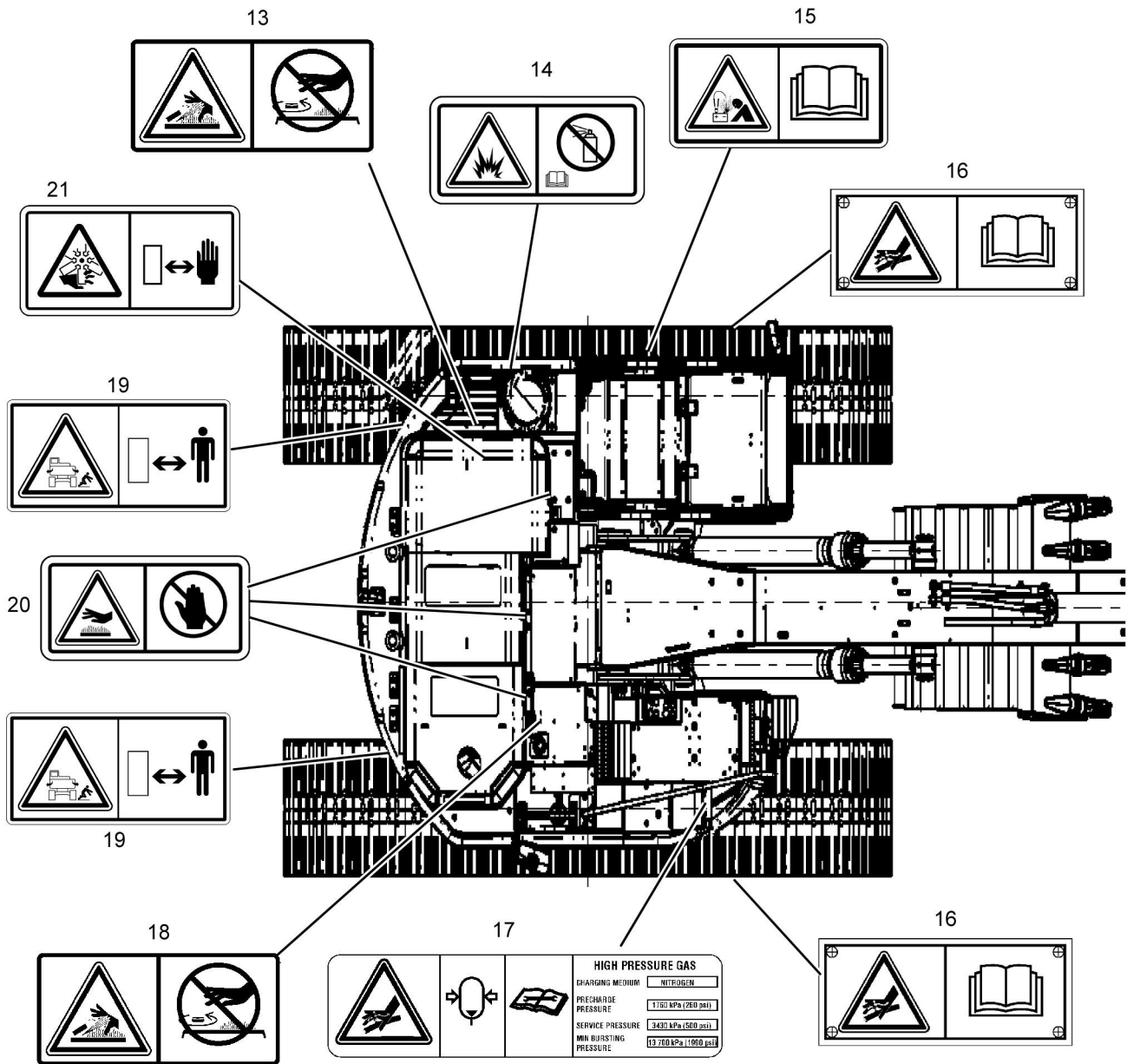

Illustration 3

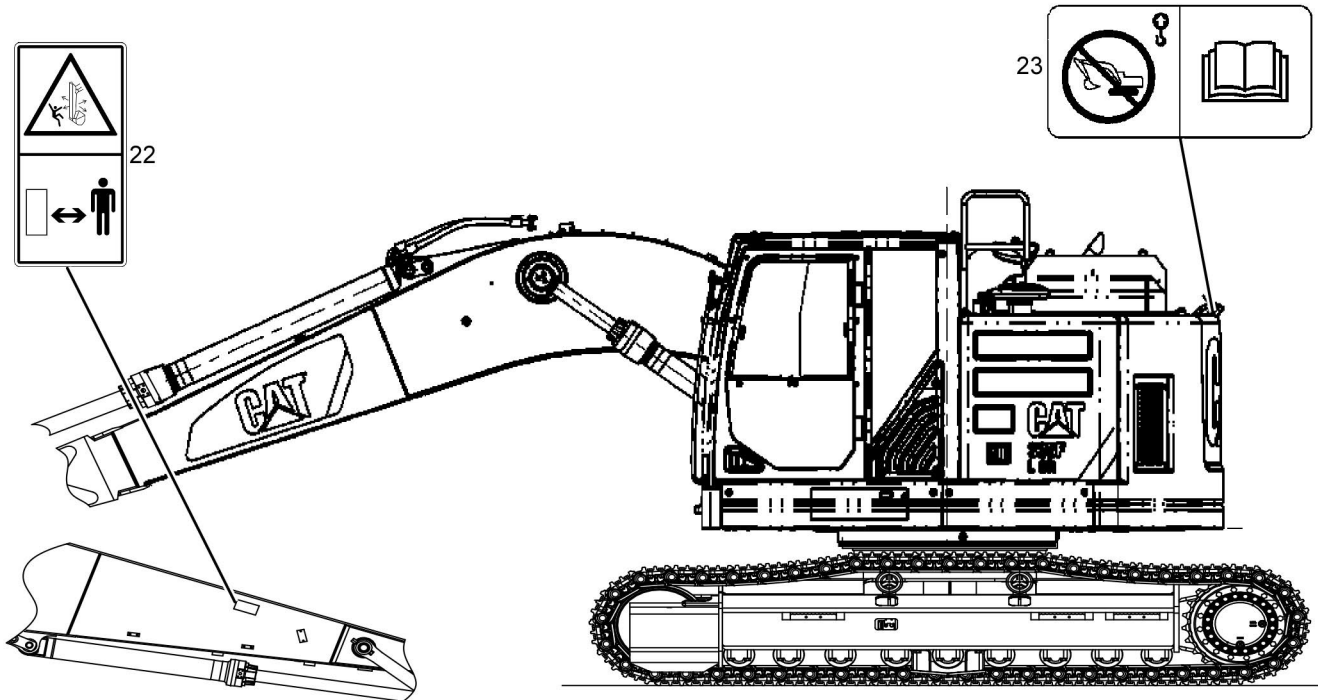

Illustration 4

g03741737

Do Not Operate (1)

This safety message is located in the cab on the right side window.

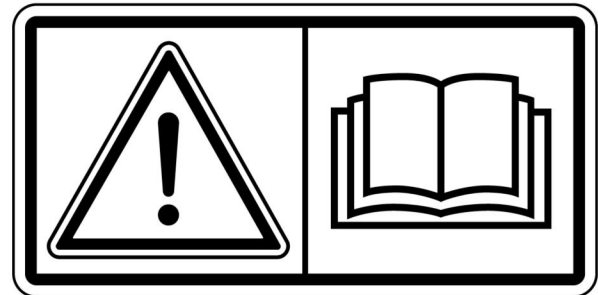

Illustration 5

g01370904

WARNING

Do not operate or work on this machine unless you have read and understand the instructions and warnings in the Operation and Maintenance Manual. Failure to follow the instructions or heed the warnings could result in injury or death. Contact any Caterpillar dealer for replacement manuals. Proper care is your responsibility.

Crushing Hazard (2)

This safety message is located in the rear of the cab.



Illustration 6

g01373978

⚠ WARNING
Personal injury can result if the window is not latched in the overhead position; ensure the auto lock is engaged.

Refer to Operation and Maintenance Manual, "Window (Front)" for further information.

Overload Warning Device (3)

If equipped, this safety message is located in the cab on the right side window.

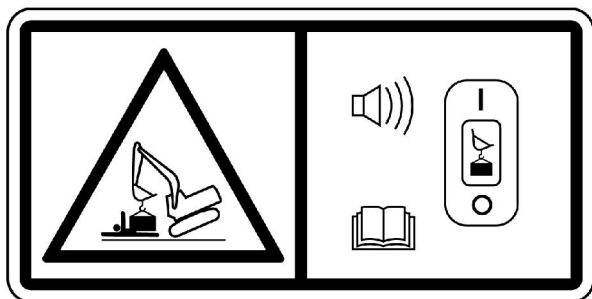

Illustration 7

g01602013

⚠ WARNING
Overloading the machine could impact the machine's stability which could result in a tipover hazard. A tipover hazard could result in serious injury or death. Always activate the overload warning device before you handle or lift objects.

Refer to Operation and Maintenance Manual, "Operator Controls" for further information.

Crushing Injury (4)

If equipped, this safety message is located in the cab on the right side window.



Illustration 8

g01374035

⚠ WARNING
Crush injury. Could cause serious injury or death. Always confirm that the quick coupler is engaged onto the pins. Read the Operator's Manual.

Refer to Operation and Maintenance Manual, "Quick Coupler Operation" for further information.

Electrical Power Lines (5)

This safety message is located in the cab on the right side window.

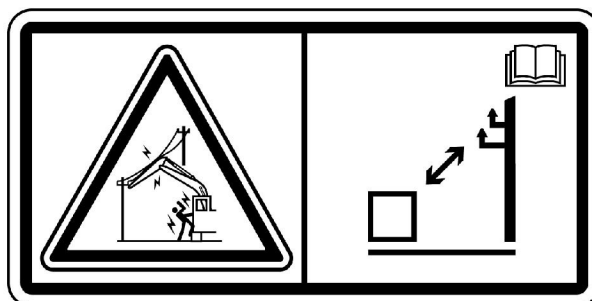

Illustration 9

g01374045

⚠ DANGER

Electrocution Hazard! Keep the machine and attachments a safe distance from electrical power. Stay clear 3 m (10 ft) plus twice the line insulator length. Read and understand the instructions and warnings in the Operation and Maintenance Manual. Failure to follow the instructions and warnings will cause serious injury or death

Refer to Operation and Maintenance Manual, "Specifications" for further information.

Crushing Hazard (6)

This safety message is located in the cab on the right side window.



Illustration 10

g01373971

WARNING

Crushing Hazard! Certain machine front linkage combinations (boom, stick, quick coupler, work tool) may require keeping the work tool away from the cab during operation. Personal injury or death may result if the work tool contacts the cab during operation.

Refer to Operation and Maintenance Manual, "Operating Technique Information" for further information.

Do Not Weld or Drill on ROPS (7)

If equipped, this safety message is located on the left side pillar in the cab.



Illustration 11

g01970802

WARNING

Structural damage, an overturn, modification, alteration, or improper repair, can impair this structure's protective capability thereby voiding this certification. Do not weld on or drill holes in the structure. Consult a Caterpillar dealer to determine this structure's limitations without voiding its certification.

This machine has been certified to the standards that are listed on the certification plate. The maximum mass of the machine, which includes the operator and the attachments without a payload, should not exceed the mass on the certification plate.

Refer to Operation and Maintenance Manual, "Guards (Operator Protection)" for more information.

Seat Belt (8)

This safety message is located in the cab on the right side window.

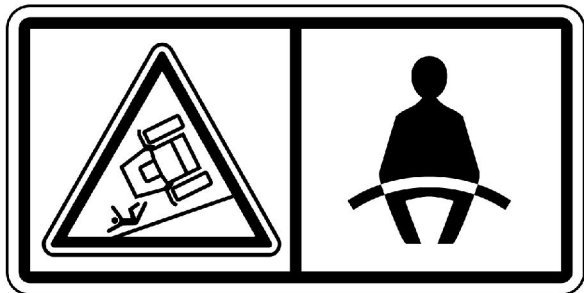

Illustration 12

g01370908

⚠ WARNING

A seat belt should be worn at all times during machine operation to prevent serious injury or death in the event of an accident or machine overturn. Failure to wear a seat belt during machine operation may result in serious injury or death.

Crushing Hazard (9)

This safety message is located in the cab on the right side window.

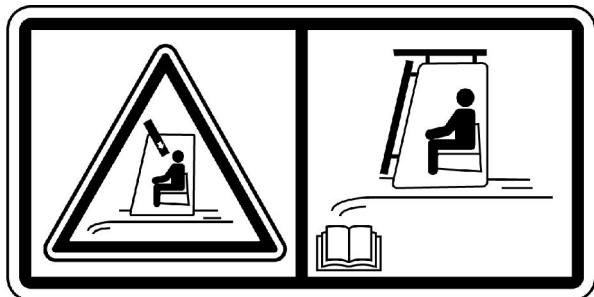

Illustration 13

g01374048

⚠ WARNING

The impact from objects that strike the front of the cab or the top of the cab could result in a crushing hazard with the potential for personal injury or death.

The front guard and the top guard should be installed on the cab for applications where the hazard of falling objects exist. Read the Operation and Maintenance Manual.

Refer to Operation and Maintenance Manual, "Guards" for further information.

Crushing Hazard (10)

If equipped, this safety message is located in the cab on the right side window.

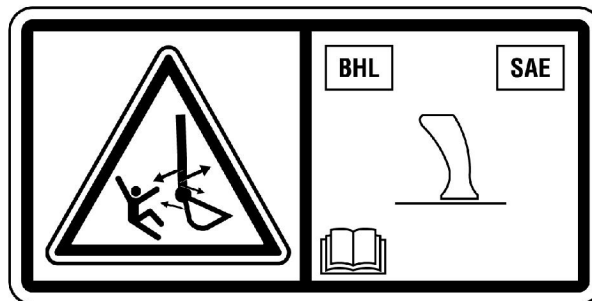

Illustration 14

g01374050

⚠ WARNING

Crush Hazard. Improper joystick setting could cause possible unexpected movement of the boom, stick, or worktool which could result in serious injury or death. Confirm that the joystick settings are properly configured before you operate the machine. Read the Operation and Maintenance Manual.

Refer to Operation and Maintenance Manual, "Joystick Controls Alternate Patterns" for further information.

Product Link (11)

If equipped, this safety message is positioned in the cab on the left side door post.

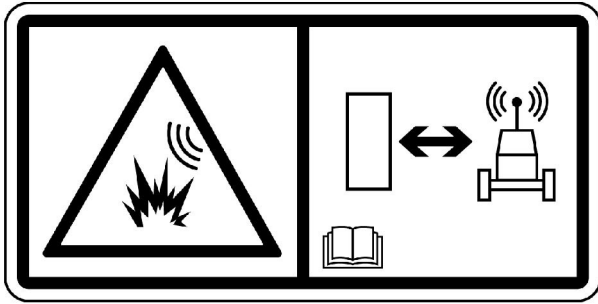

Illustration 15

g01370917

WARNING

This machine is equipped with a Caterpillar Product Link communication device. When electric detonators are used, this communication device should be deactivated within 12 m (40 ft) of a blast site for satellite-based systems and within 3 m (10 ft) of a blast site for cellular based systems, or within the distance mandated under applicable legal requirements. Failure to do so could cause interference with blasting operations and result in serious injury or death.

In cases where the type of Product Link module cannot be identified, Caterpillar recommends that the device be disabled no less than 12 m (40 ft) from the blast perimeter.

Refer to Operation and Maintenance Manual , "Product Link" for further information.

Crushing Hazard (12)

This safety message is located in the cab on the right side window.

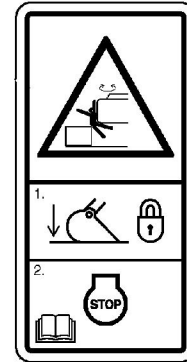

Illustration 16

g02282255

WARNING

Crush Hazard! A machine may move unexpectedly and without warning resulting in personal injury or death.

Before leaving the machine lower the work tool to the ground, lock operator controls, shut off the engine and remove the key.

Refer to Operation and Maintenance Manual, "Diesel Particulate Filter Regeneration" for further information.

Pressurized System (13)

This safety message is located inside the engine compartment next to the cooling system filler cap.



Illustration 17

g01371640

⚠ WARNING

Pressurized system! Hot coolant can cause serious burns, injury or death. To open the cooling system filler cap, stop the engine and wait until the cooling system components are cool. Loosen the cooling system pressure cap slowly in order to relieve the pressure. Read and understand the Operation and Maintenance Manual before performing any cooling system maintenance.

Refer to Operation and Maintenance Manual, "Cooling System Coolant Level - Check" for further information.

Aerosol Starting Aid (14)

This safety message is positioned on the housing of the engine air filter.



Illustration 18

g01372254

⚠ WARNING

Explosion hazard! Do not use ether! This machine is equipped with an air inlet heater. Using ether can create explosions or fires that can cause personal injury or death. Read and follow the starting procedure in the Operation and Maintenance Manual.

Refer to Operation and Maintenance Manual, "Engine Starting" for the proper starting procedure.

Jump Start Cables (15)

This safety message is positioned on the circuit breaker panel.

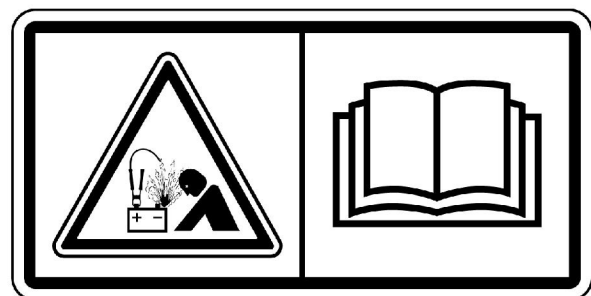

Illustration 19

g01370909

⚠ WARNING

Explosion Hazard! Improper jumper cable connections can cause an explosion resulting in serious injury or death. Batteries may be located in separate compartments. Refer to the Operation and Maintenance Manual for the correct jump starting procedure.

Refer to Operation and Maintenance Manual, "Engine Starting with Jump Start Cables" for further information.

High Pressure Cylinder (16)

This safety message is positioned on the track adjuster on both sides of the machine.

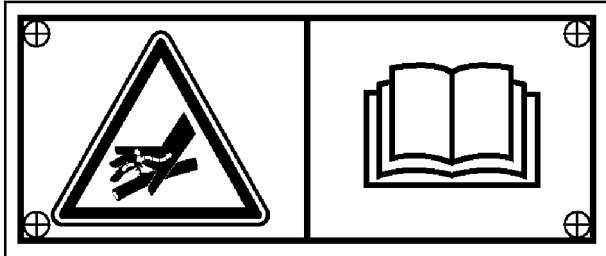

Illustration 20

g01076729

WARNING

High Pressure Cylinder. Do not remove any parts from the cylinder until all of the pressure has been relieved. This will prevent possible personal injury or death.

Refer to Operation and Maintenance Manual, "Track Adjustment - Adjust" for the adjustment procedure.

High Pressure Gas (17)

This safety message is positioned on the accumulator.

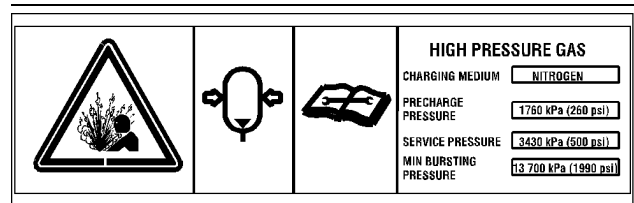

Illustration 21

g01055412

WARNING

This system contains high pressure gas. Failure to follow the instructions and warnings could cause an explosion, resulting in possible injury or death.

Do not expose to fire. Do not weld. Do not drill. Relieve pressure before discharging.

See Operation and Maintenance Manual for charging and discharging. See your Caterpillar Dealer for tools and detailed information.

Refer to Operation and Maintenance Manual, "Equipment Lowering with Engine Stopped" for further information.

Relieve Hydraulic Tank Pressure (18)

This safety message is located on top of the hydraulic tank.



Illustration 22

g01371640

! WARNING
HYDRAULIC TANK
 RELIEVE TANK PRESSURE WITH ENGINE OFF
 BY REMOVING CAP SLOWLY TO PREVENT
 BURNS FROM HOT OIL.

Crushing Hazard (19)

This safety message is located on the rear of each side of the machine.

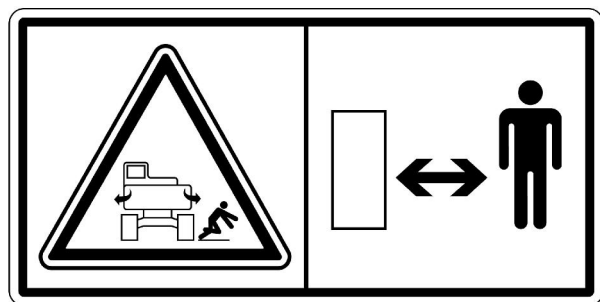

Illustration 23

g01374060

! WARNING
 Machine swings. Stay back. Crushing hazard
 could cause serious injury or death.

Hot Surface (20)

This safety message is located in three locations on the engine hood.



Illustration 24

g01372256

! WARNING
 Engine hood and engine hood parts can be hot while engine is running or immediately after engine shutdown. Hot parts or hot components can cause burns or personal injury. Do not allow these parts to contact your skin, when engine is running or immediately after engine shutdown. Use protective clothing or protective equipment to protect your skin.

Rotating Fan (21)

This safety message is located near the engine fan.

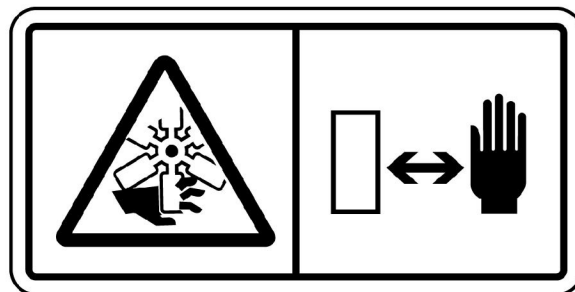

Illustration 25

g01385578

! WARNING
 Cutting Hazard! Keep hands clear of fan while engine is running. May cause serious injury or death.

Crushing Hazard (22)

This safety message is located on both sides of the stick.

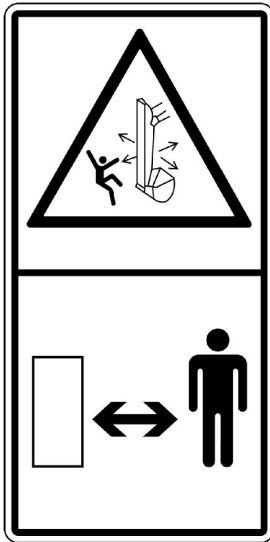

Illustration 26

g01385579

⚠ WARNING

A crushing hazard exists when the stick and boom are in motion and when the machine is being used in object handling applications. Failure to stay clear of the stick and boom when the machine is in operation can result in personal injury or death. Stay clear of the stick and boom when the machine is in operation.

Lifting Restriction/Counterweight Only (23)

This safety message is located on top of the counterweight.

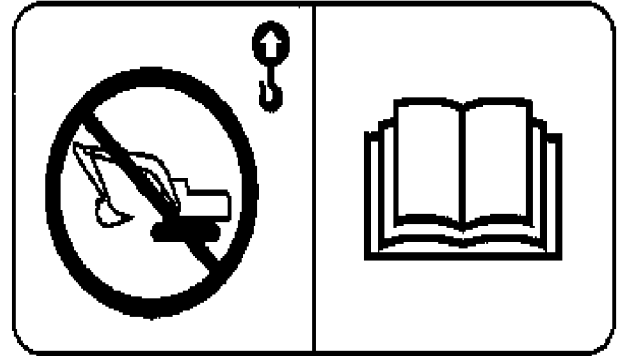

Illustration 27

g03481698

⚠ WARNING

The rear link on the counterweight should be used for the counterweight only. Do not lift the whole Machine by these counterweight links. This could cause serious injury or death. Read Operation and Maintenance Manuals.

See the Operation and Maintenance Manual, "Lifting and Tying Down the Machine" and "Counterweight Removal and Installation" for information on your product.

i06896860

Additional Messages

SMCS Code: 7000; 7405

There are several specific messages on this machine. The exact location of the messages and the description of the messages are reviewed in this section. Please become familiarized with all messages.

Make sure that all of the messages are legible. Clean the messages or replace the messages if you cannot read the words. Replace the illustrations if the illustrations are not legible. When you clean the messages, use a cloth, water, and soap. Do not use solvent, gasoline, or other harsh chemicals to clean the messages. Solvents, gasoline, or harsh chemicals could loosen the adhesive that secures the messages. Loose adhesive will allow the messages to fall.

Replace any message that is damaged, or missing. If a message is attached to a part that is replaced, install a message on the replacement part. Any Caterpillar dealer can provide new messages.

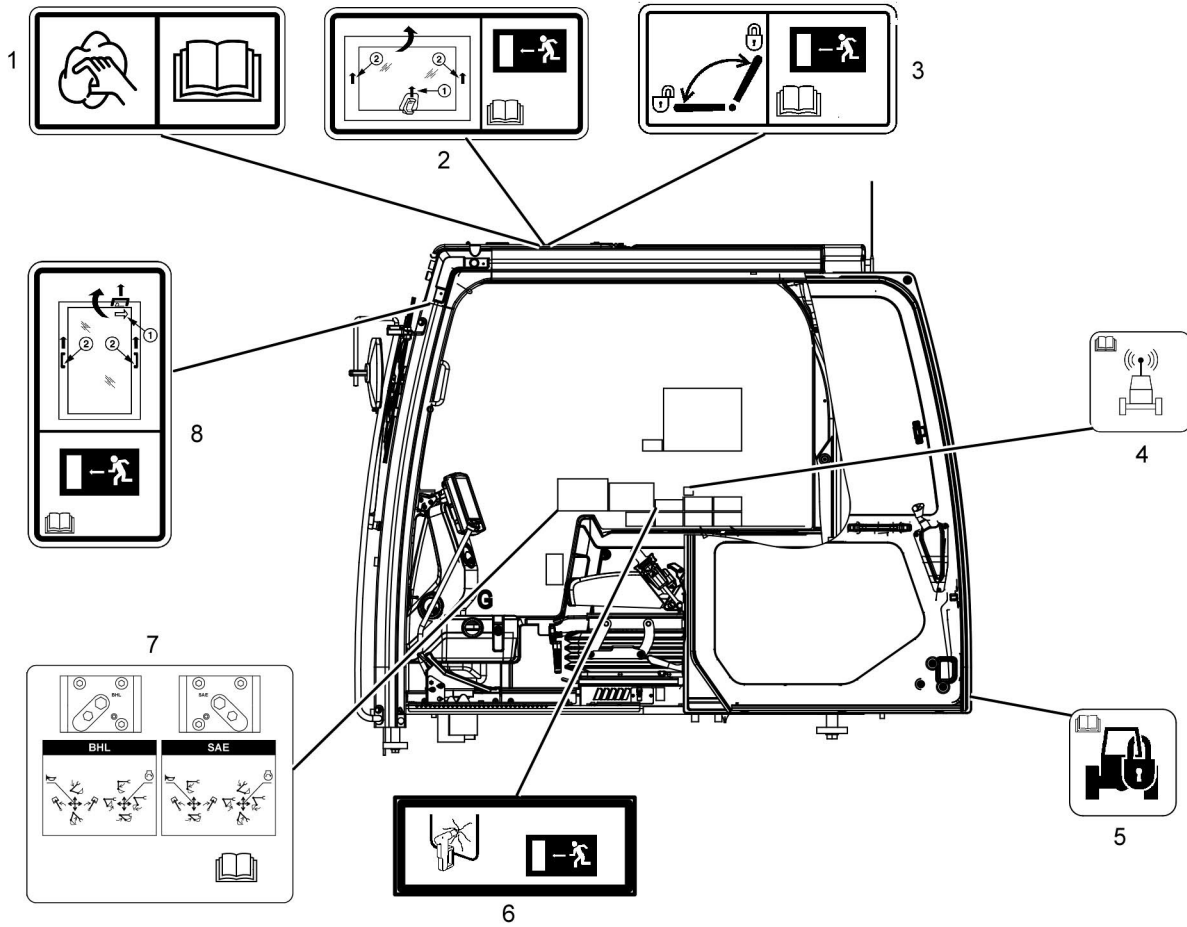

Illustration 28

g03731738

Safety Section
Additional Messages

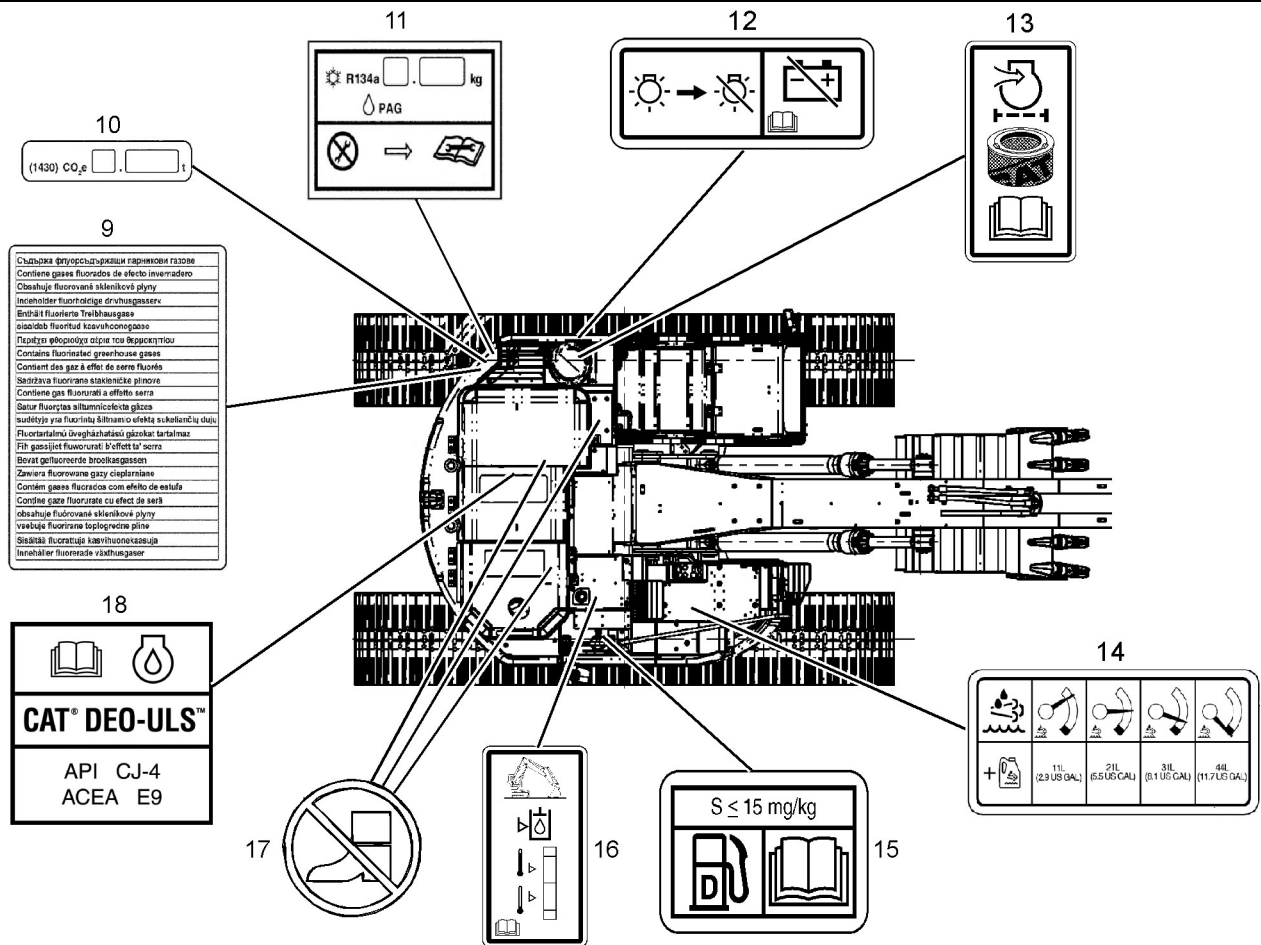

Illustration 29

g06157031

Cleaning Windows (1)

This message is located in the cab on the polycarbonate windows.

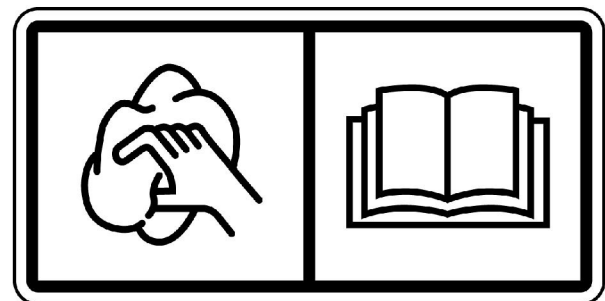

Illustration 30

g01134495

NOTICE
Clean windows with a wet cloth or sponge. Dry cloth or sponge may scratch window material.

Alternate Exit (2)

If equipped, this message is located on the roof hatch.

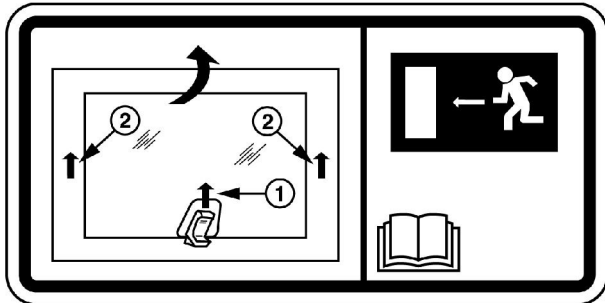

Illustration 31 g02052833

If the Primary exits are blocked, exit the machine through the opening.

For more information, refer to Operation and Maintenance Manual, "Alternate Exit".

Alternate Exit Lock/Unlock (3)

If equipped, this message is located on the roof hatch.

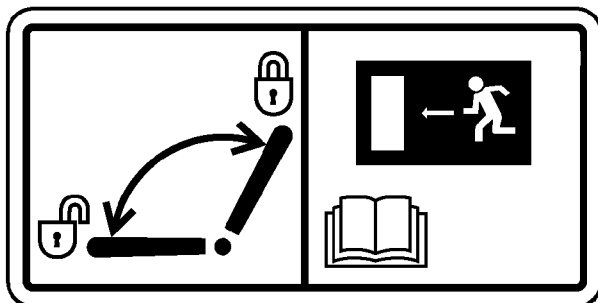

Illustration 32 g02052873

NOTICE

Unlock alternate exit window during machine operations.

Move the lever to the left to the UNLOCK position. Move the lever to the right to the LOCK position. Exit through the opening.

For more information, refer to Operation and Maintenance Manual, "Alternate Exit".

Data Privacy (4)

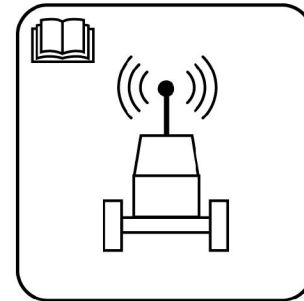

Illustration 33 g01418953

The Product Link System is a satellite communication device that transmits information regarding the machine back to Caterpillar and Cat dealers and customers. All logged events and diagnostic codes that are available to the Cat Electronic Technician (ET) on the Cat data link can be sent to the satellite. Information can also be sent to the Product Link System. The information is used to improve Cat products and Cat services.

Refer to Operation and Maintenance Manual, "Product Link" for more information.

Machine Security System (5)

This message is located on the bottom corner of the cab door.



Illustration 34 g00951606

This machine may be equipped with a security system. Read the Operation and Maintenance Manual before you operate the machine.

Refer to Operation and Maintenance Manual, "Machine Security System" for more information.

Alternate Exit (6)

If equipped, this message is located on the right side window of the cab.

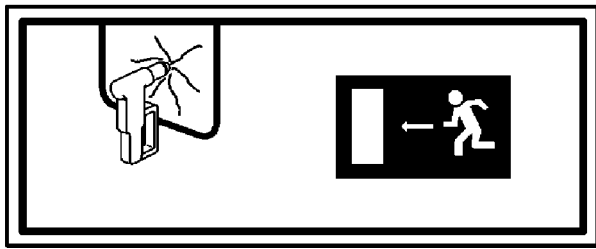

Illustration 35

g01069768

Break glass in order to exit.

Refer to Operation and Maintenance Manual, "Alternate Exit" for further information.

Joystick Controls Alternate Patterns (7)

If equipped, this message is located on the right side window of the cab.

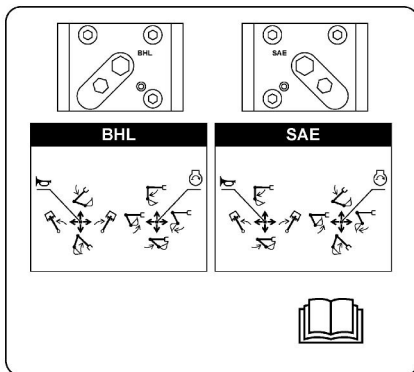

Illustration 36

g01233974

Refer to Operation and Maintenance Manual, "Joystick Controls Alternate Patterns" for further information.

Alternate Exit (8)

If equipped, this message is located on the front window of the cab in the upper left-hand corner.



Illustration 37

g02052913

Move the lever to the right in order to unlock the front window. Raise the window into the storage position. Exit through the opening.

Refer to Operation and Maintenance Manual, "Alternate Exit" for further information.

Air Conditioner (9), (10), (11)

These messages are positioned on the left door behind the cab.

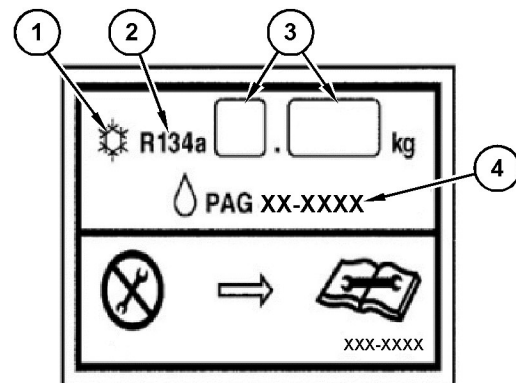

Illustration 38

g06155396

- (1) Air conditioning symbol
- (2) R134a (Refrigerant type common name)
- (3) The system contains 1.0 kg of refrigerant
- (4) The lubricating oil type for this system is PAG (polyalkylene glycol)

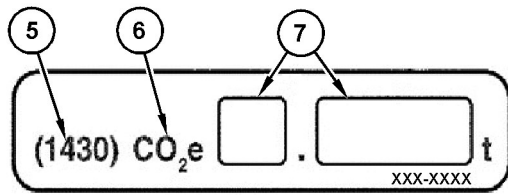

Illustration 39 g06155409

If equipped, this plate provides the below additional European Union required greenhouse gas information.

- (5) (1430) - This is the Global Warming Potential of R134a
- (6) CO₂ equivalent
- (7) The system contains 1.430 metric tonne of CO₂ equivalent

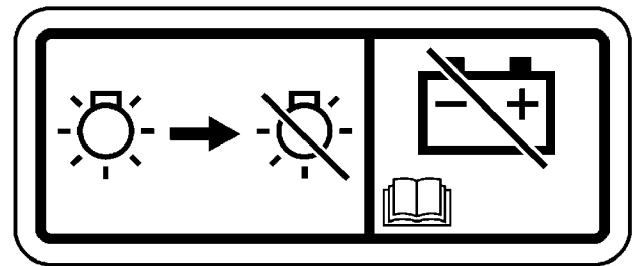

Illustration 41 g03422337

NOTICE

After the engine is shutdown apply the battery disconnect switch. Applying the battery disconnect too soon will prevent the DEF system from being purged and could cause DEF to freeze in the lines.

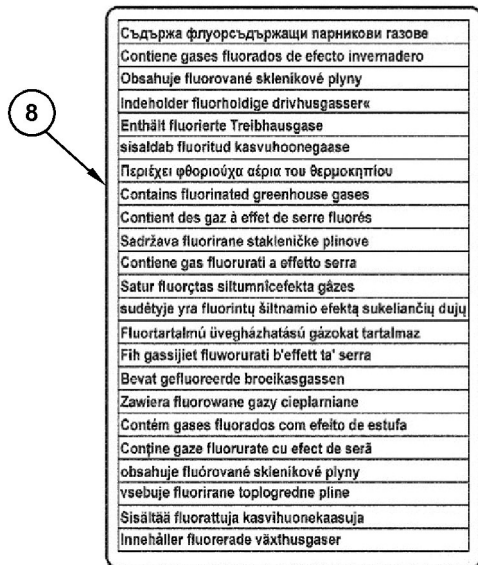

Illustration 40 g06155418

(8) If equipped, this film provides the required language translations of the text "Contains fluorinated greenhouse gases" for the European Union greenhouse gas regulation.

These messages for the air conditioner system have the appropriate information for the following services: the air conditioner lubricant, the refrigerant charge, and the refrigerant capacity.

Do not service the air conditioner system before reading the service manual.

Wait To Disconnect Lamp(12)

This message is located behind the cab near the disconnect switch.

Radial Seal Air Filters (13)

This message is located on the air cleaner.

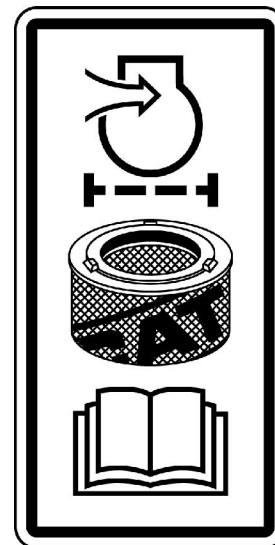

Illustration 42 g01134494

To avoid engine damage, use only Cat radial seal air filters. Other filters will not seal properly. Read the Operation and Maintenance Manual.

Refer to Operation and Maintenance Manual, "Engine Air Filter Primary Element - Clean/Replace".

Diesel Exhaust Fluid Fill (14)

This message is located on the right side of the machine near the storage box.

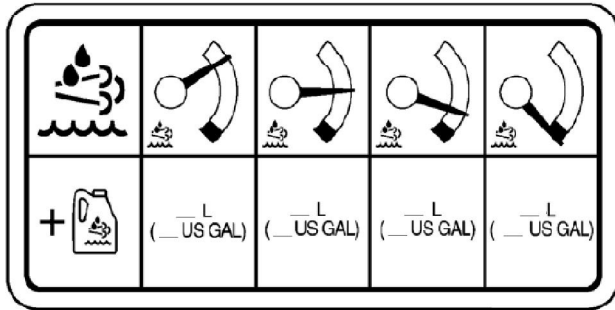

Illustration 43 g03650401

This film provides an estimate of diesel exhaust fluid needed to fill the DEF tank.

Refer to Operation and Maintenance Manual, "Lubricant Viscosities" and Operation and Maintenance Manual, "Diesel Exhaust Fluid - Fill" for more information.

Diesel Fuel Requirements (15)

This message is located by the fuel tank.

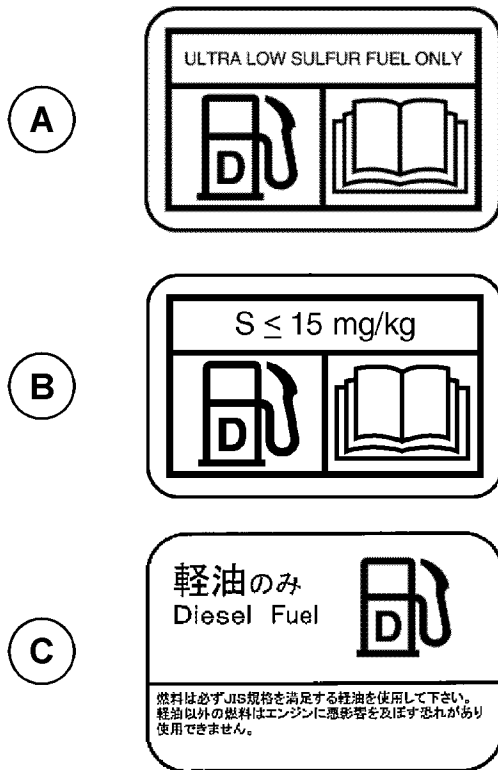

Illustration 44 g03218956

- (A) NACD film
- (B) EAME film
- (C) Japan film

Use Ultralow Sulfur Diesel (ULSD) fuel.

Refer to Operation and Maintenance Manual, "Lubricant Viscosities".

Hydraulic Oil Level Check (16)

This message is located in the right access compartment next to the sight gauge for the hydraulic oil.

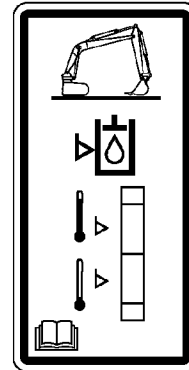

Illustration 45 g01069075

Check hydraulic oil level daily. See Operation and Maintenance Manual, "Hydraulic System Oil Level - Check" for details.

No Step (17)

This message is located on the engine hood on the top of the machine. This message is also located on the left side of the machine behind the cab, as well as on the engine valve cover.

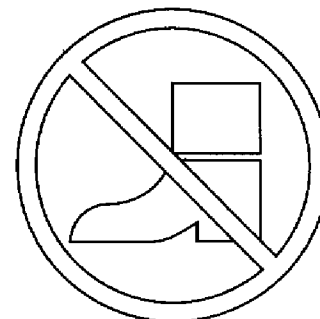

Illustration 46 g00911158

Do not step in this area.

Engine Oil Requirements (18)

This message is located on top of the engine.

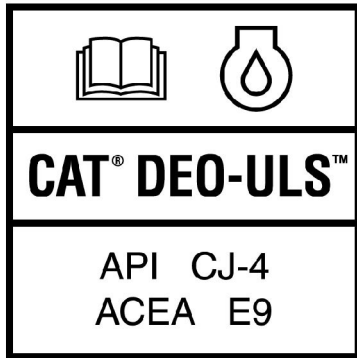

Illustration 47

g02176761

Refer to Operation and Maintenance Manual, "Lubricant Viscosities".

i07746355

General Hazard Information

SMCS Code: 7000

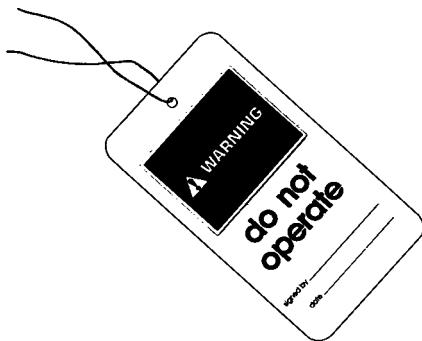

Illustration 48

g00104545

Typical example

Attach a "Do Not Operate" warning tag or a similar warning tag to the start switch or to the controls. Attach the warning tag before you service the equipment or before you repair the equipment. Warning tag SEHS7332 is available from your Cat dealer.

WARNING

Operating the machine while distracted can result in the loss of machine control. Use extreme caution when using any device while operating the machine. Operating the machine while distracted can result in personal injury or death.

Know the width of your equipment to maintain proper clearance when you operate the equipment near fences or near boundary obstacles.

Be aware of high-voltage power lines and power cables that are buried. If the machine comes in contact with these hazards, serious injury or death may occur from electrocution.

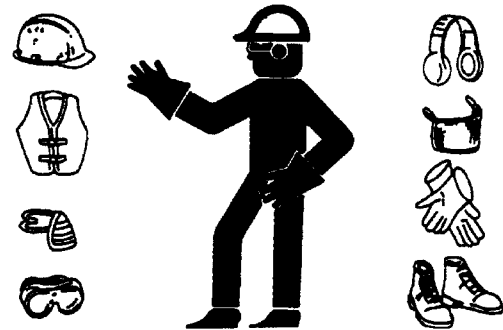

Illustration 49

g00702020

Wear a hard hat, protective glasses, and other protective equipment, as required.

Do not wear loose clothing or jewelry that can snag on controls or on other parts of the equipment.

Make sure that all protective guards and all covers are secured in place on the equipment.

Keep the equipment free from foreign material. Remove debris, oil, tools, and other items from the deck, from walkways, and from steps.

Secure all loose items such as lunch boxes, tools, and other items that are not a part of the equipment.

Know the appropriate work site hand signals and the personnel that are authorized to give the hand signals. Accept hand signals from one person only.

Do not smoke when you service an air conditioner. Also, do not smoke if refrigerant gas may be present. Inhaling the fumes that are released from a flame that contacts air conditioner refrigerant can cause bodily harm or death. Inhaling gas from air conditioner refrigerant through a lighted cigarette can cause bodily harm or death.

Never put maintenance fluids into glass containers. Drain all liquids into a suitable container.

Obey all local regulations for the disposal of liquids.

Use all cleaning solutions with care. Report all necessary repairs.

Do not allow unauthorized personnel on the equipment.

Unless you are instructed otherwise, perform maintenance with the equipment in the servicing position. Refer to Operation and Maintenance Manual for the procedure for placing the equipment in the servicing position.

When you perform maintenance above ground level, use appropriate devices such as ladders or man lift machines. If equipped, use the machine anchorage points and use approved fall arrest harnesses and lanyards.

Pressurized Air and Water

Pressurized air and/or water can cause debris and/or hot water to be blown out. The debris and/or hot water could result in personal injury.

When pressurized air and/or pressurized water is used for cleaning, wear protective clothing, protective shoes, and eye protection. Eye protection includes goggles or a protective face shield.

The maximum air pressure for cleaning purposes must be reduced to 205 kPa (30 psi) when the nozzle is deadheaded and the nozzle is used with an effective chip deflector and personal protective equipment. The maximum water pressure for cleaning purposes must be below 275 kPa (40 psi).

Avoid direct spraying of water on electrical connectors, connections, and components. When using air for cleaning, allow the machine to cool to reduce the possibility of fine debris igniting when re-deposited on hot surfaces.

Trapped Pressure

Pressure can be trapped in a hydraulic system. Releasing trapped pressure can cause sudden machine movement or attachment movement. Use caution if you disconnect hydraulic lines or fittings. High-pressure oil that is released can cause a hose to whip. High-pressure oil that is released can cause oil to spray. Fluid penetration can cause serious injury and possible death.

Fluid Penetration

Pressure can be trapped in the hydraulic circuit long after the machine has been stopped. The pressure can cause hydraulic fluid or items such as pipe plugs to escape rapidly if the pressure is not relieved correctly.

Do not remove any hydraulic components or parts until pressure has been relieved or personal injury may occur. Do not disassemble any hydraulic components or parts until pressure has been relieved or personal injury may occur. Refer to the Service Manual for any procedures that are required to relieve the hydraulic pressure.

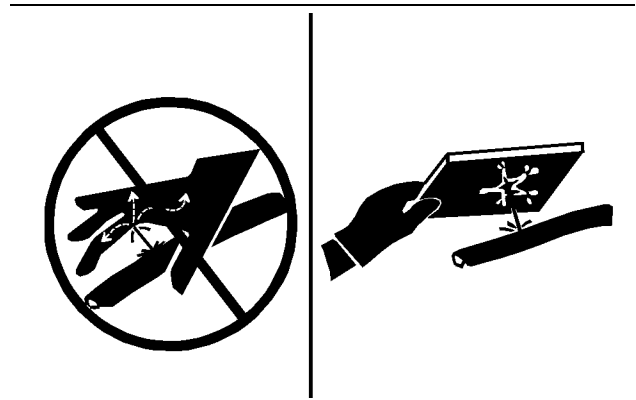

Illustration 50

g00687600

Always use a board or cardboard when you check for a leak. Leaking fluid that is under pressure can penetrate body tissue. Fluid penetration can cause serious injury and possible death. A pin hole leak can cause severe injury. If fluid is injected into your skin, you must get treatment immediately. Seek treatment from a doctor that is familiar with this type of injury.

Containing Fluid Spillage

Care must be taken in order to ensure that fluids are contained during performance of inspection, maintenance, testing, adjusting, and repair of the equipment. Prepare to collect the fluid with suitable containers before opening any compartment or disassembling any component that contains fluids.

Refer to Special Publication, NENG2500, "Cat dealer Service Tool Catalog" for the following items:

- Tools that are suitable for collecting fluids and equipment that is suitable for collecting fluids
- Tools that are suitable for containing fluids and equipment that is suitable for containing fluids

Obey all local regulations for the disposal of liquids.

Inhalation

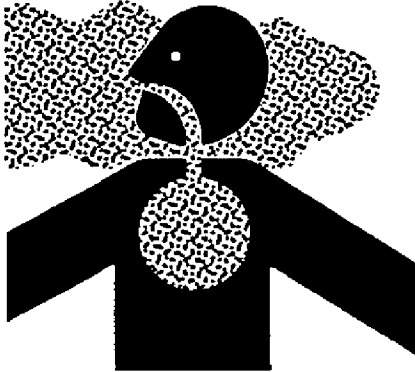

Illustration 51

g02159053

Exhaust

Use caution. Exhaust fumes can be hazardous to your health. If you operate the machine in an enclosed area, adequate ventilation is necessary.

Asbestos Information

Cat equipment and replacement parts that are shipped from Caterpillar are asbestos free. Caterpillar recommends the use of only genuine Cat replacement parts. Use the following guidelines when you handle any replacement parts that contain asbestos or when you handle asbestos debris.

Use caution. Avoid inhaling dust that might be generated when you handle components that contain asbestos fibers. Inhaling this dust can be hazardous to your health. The components that may contain asbestos fibers are brake pads, brake bands, lining material, clutch plates, and some gaskets. The asbestos that is used in these components is bound in a resin or sealed in some way. Normal handling is not hazardous unless airborne dust that contains asbestos is generated.

If dust that may contain asbestos is present, there are several guidelines that should be followed:

- Never use compressed air for cleaning.
- Avoid brushing materials that contain asbestos.
- Avoid grinding materials that contain asbestos.
- Use a wet method in order to clean up asbestos materials.
- A vacuum cleaner that is equipped with a high efficiency particulate air filter (HEPA) can also be used.

- Use exhaust ventilation on permanent machining jobs.
- Wear an approved respirator if there is no other way to control the dust.
- Comply with applicable rules and regulations for the work place. In the United States, use Occupational Safety and Health Administration (OSHA) requirements. These OSHA requirements can be found in "29 CFR 1910.1001". In Japan, use the requirements found in the "Ordinance on Prevention of Health Impairment due to Asbestos" in addition to the requirements of the Industrial Safety and Health Act.
- Obey environmental regulations for the disposal of asbestos.
- Stay away from areas that might have asbestos particles in the air.

Dispose of Waste Properly

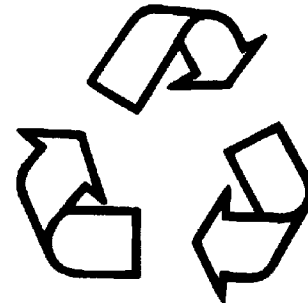

Illustration 52

g00706404

Improperly disposing of waste can threaten the environment. Potentially harmful fluids should be disposed of according to local regulations.

Always use leakproof containers when you drain fluids. Do not pour waste onto the ground, down a drain, or into any source of water.

i01359664

Crushing Prevention and Cutting Prevention

SMCS Code: 7000

Support the equipment properly before you perform any work or maintenance beneath that equipment. Do not depend on the hydraulic cylinders to hold up the equipment. Equipment can fall if a control is moved, or if a hydraulic line breaks.

Safety Section

Burn Prevention

Do not work beneath the cab of the machine unless the cab is properly supported.

Unless you are instructed otherwise, never attempt adjustments while the machine is moving or while the engine is running.

Never jump across the starter solenoid terminals in order to start the engine. Unexpected machine movement could result.

Whenever there are equipment control linkages the clearance in the linkage area will change with the movement of the equipment or the machine. Stay clear of areas that may have a sudden change in clearance with machine movement or equipment movement.

Stay clear of all rotating and moving parts.

If it is necessary to remove guards in order to perform maintenance, always install the guards after the maintenance is performed.

Keep objects away from moving fan blades. The fan blade will throw objects or cut objects.

Do not use a kinked wire cable or a frayed wire cable. Wear gloves when you handle wire cable.

When you strike a retainer pin with force, the retainer pin can fly out. The loose retainer pin can injure personnel. Make sure that the area is clear of people when you strike a retainer pin. To avoid injury to your eyes, wear protective glasses when you strike a retainer pin.

Chips or other debris can fly off an object when you strike the object. Make sure that no one can be injured by flying debris before striking any object.

i07746334

Burn Prevention

SMCS Code: 7000

Do not touch any part of an operating engine. Allow the engine to cool before any maintenance is performed on the engine. Relieve all pressure in the air system, in the oil system, in the lubrication system, in the fuel system, or in the cooling system before any lines, fittings, or related items are disconnected.

Coolant

When the engine is at operating temperature, the engine coolant is hot. The coolant is also under pressure. The radiator and all lines to the heaters or to the engine contain hot coolant.

Any contact with hot coolant or with steam can cause severe burns. Allow cooling system components to cool before the cooling system is drained.

Check the coolant level only after the engine has been stopped.

Ensure that the filler cap is cool before removing the filler cap. The filler cap must be cool enough to touch with a bare hand. Remove the filler cap slowly to relieve pressure.

Cooling system conditioner contains alkali. Alkali can cause personal injury. Do not allow alkali to contact the skin, the eyes, or the mouth.

Oils

Hot oil and hot components can cause personal injury. Do not allow hot oil to contact the skin. Also, do not allow hot components to contact the skin.

Remove the hydraulic tank filler cap only after the engine has been stopped. The filler cap must be cool enough to touch with a bare hand. Follow the standard procedure in this manual to remove the hydraulic tank filler cap.

Batteries

The liquid in a battery is an electrolyte. Electrolyte is an acid that can cause personal injury. Do not allow electrolyte to contact the skin or the eyes.

Do not smoke while checking the battery electrolyte levels. Batteries give off flammable fumes which can explode.

Always wear protective glasses when you work with batteries. Wash hands after touching batteries. The use of gloves is recommended.

i06179517

Fire Prevention and Explosion Prevention

SMCS Code: 7000



Illustration 53

g00704000

Regeneration

The exhaust gas temperatures during regeneration will be elevated. Follow proper fire prevention instructions and use the disable regeneration function (if equipped) when appropriate.

General

All fuels, most lubricants, and some coolant mixtures are flammable.

To minimize the risk of fire or explosion, Caterpillar recommends the following actions.

Always perform a Walk-Around Inspection, which may help you identify a fire hazard. Do not operate a machine when a fire hazard exists. Contact your Cat dealer for service.

Understand the use of the primary exit and alternative exit on the machine. Refer to Operation and Maintenance Manual, "Alternative Exit".

Do not operate a machine with a fluid leak. Repair leaks and clean up fluids before resuming machine operation. Fluids that are leaking or spilled onto hot surfaces or onto electrical components can cause a fire. A fire may cause personal injury or death.

Remove flammable material such as leaves, twigs, papers, trash, and so on. These items may accumulate in the engine compartment or around other hot areas and hot parts on the machine.

Keep the access doors to major machine compartments closed and access doors in working condition in order to permit the use of fire suppression equipment, in case a fire should occur.

Clean all accumulations of flammable materials such as fuel, oil, and debris from the machine.

Do not operate the machine near any flame.

Keep shields in place. Exhaust shields (if equipped) protect hot exhaust components from oil spray or fuel spray in a break in a line, in a hose, or in a seal. Exhaust shields must be installed correctly.

Do not weld or flame cut on tanks or lines that contain flammable fluids or flammable material. Empty and purge the lines and tanks. Then clean the lines and tanks with a nonflammable solvent prior to welding or flame cutting. Ensure that the components are properly grounded in order to avoid unwanted arcs.

Dust that is generated from repairing nonmetallic hoods or fenders may be flammable and/or explosive. Repair such components in a ventilated area away from open flames or sparks. Use suitable Personal Protection Equipment (PPE).

Inspect all lines and hoses for wear or deterioration. Replace damaged lines and hoses. The lines and the hoses should have adequate support and secure clamps. Tighten all connections to the recommended torque. Damage to the protective cover or insulation may provide fuel for fires.

Store fuels and lubricants in properly marked containers away from unauthorized personnel. Store oily rags and flammable materials in protective containers. Do not smoke in areas that are used for storing flammable materials.



Illustration 54

g03839130

Use caution when you are fueling a machine. Do not smoke while you are fueling a machine. Do not fuel a machine near open flames or sparks. Do not use cell phones or other electronic devices while you are refueling. Always stop the engine before fueling. Fill the fuel tank outdoors. Properly clean areas of spillage.

Avoid static electricity risk when fueling. Ultra low sulfur diesel (ULSD) poses a greater static ignition hazard than earlier diesel formulations with a higher sulfur content. Avoid death or serious injury from fire or explosion. Consult with your fuel or fuel system supplier to ensure that the delivery system is in compliance with fueling standards for proper grounding and bonding practices.

Never store flammable fluids in the operator compartment of the machine.

Battery and Battery Cables



Illustration 55

g03839133

Caterpillar recommends the following in order to minimize the risk of fire or an explosion related to the battery.

Do not operate a machine if battery cables or related parts show signs of wear or damage. Contact your Cat dealer for service.

Follow safe procedures for engine starting with jump-start cables. Improper jumper cable connections can cause an explosion that may result in injury. Refer to Operation and Maintenance Manual, "Engine Starting with Jump Start Cables" for specific instructions.

Do not charge a frozen battery. This may cause an explosion.

Gases from a battery can explode. Keep any open flames or sparks away from the top of a battery. Do not smoke in battery charging areas. Do not use cell phones or other electronic devices in battery charging areas.

Never check the battery charge by placing a metal object across the terminal posts. Use a voltmeter in order to check the battery charge.

Daily inspect battery cables that are in areas that are visible. Inspect cables, clips, straps, and other restraints for damage. Replace any damaged parts. Check for signs of the following, which can occur over time due to use and environmental factors:

- Fraying

- Abrasion
- Cracking
- Discoloration
- Cuts on the insulation of the cable
- Fouling
- Corroded terminals, damaged terminals, and loose terminals

Replace damaged battery cable(s) and replace any related parts. Eliminate any fouling, which may have caused insulation failure or related component damage or wear. Ensure that all components are reinstalled correctly.

An exposed wire on the battery cable may cause a short to ground if the exposed area comes into contact with a grounded surface. A battery cable short produces heat from the battery current, which may be a fire hazard.

An exposed wire on the ground cable between the battery and the disconnect switch may cause the disconnect switch to be bypassed if the exposed area comes into contact with a grounded surface. This may result in an unsafe condition for servicing the machine. Repair components or replace components before servicing the machine.

WARNING

Fire on a machine can result in personal injury or death. Exposed battery cables that come into contact with a grounded connection can result in fires. Replace cables and related parts that show signs of wear or damage. Contact your Cat dealer.

Wiring

Check electrical wires daily. If any of the following conditions exist, replace parts before you operate the machine.

- Fraying
- Signs of abrasion or wear
- Cracking
- Discoloration
- Cuts on insulation
- Other damage

Make sure that all clamps, guards, clips, and straps are reinstalled correctly. This will help to prevent vibration, rubbing against other parts, and excessive heat during machine operation.

Attaching electrical wiring to hoses and tubes that contain flammable fluids or combustible fluids should be avoided.

Consult your Cat dealer for repair or for replacement parts.

Keep wiring and electrical connections free of debris.

Lines, Tubes, and Hoses

Do not bend high-pressure lines. Do not strike high-pressure lines. Do not install any lines that are bent or damaged. Use the appropriate backup wrenches in order to tighten all connections to the recommended torque.

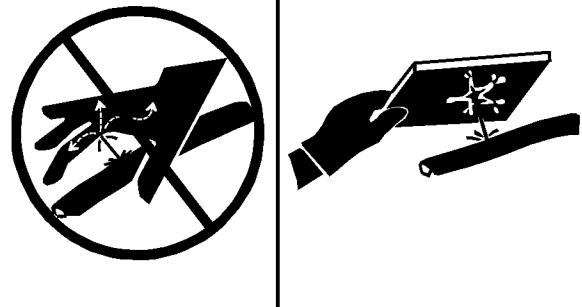

Illustration 56

g00687600

Check lines, tubes, and hoses carefully. Wear Personal Protection Equipment (PPE) in order to check for leaks. Always use a board or cardboard when you check for a leak. Leaking fluid that is under pressure can penetrate body tissue. Fluid penetration can cause serious injury and possible death. A pin hole leak can cause severe injury. If fluid is injected into your skin, you must get treatment immediately. Seek treatment from a doctor that is familiar with this type of injury.

Replace the affected parts if any of the following conditions are present:

- End fittings are damaged or leaking.
- Outer coverings are chafed or cut.
- Wires are exposed.
- Outer coverings are swelling or ballooning.
- Flexible parts of the hoses are kinked.
- Outer covers have exposed embedded armoring.
- End fittings are displaced.

Make sure that all clamps, guards, and heat shields are installed correctly. During machine operation, this will help to prevent vibration, rubbing against other parts, excessive heat, and failure of lines, tubes, and hoses.

Do not operate a machine when a fire hazard exists. Repair any lines that are corroded, loose, or damaged. Leaks may provide fuel for fires. Consult your Cat dealer for repair or for replacement parts. Use genuine Cat parts or the equivalent, for capabilities of both the pressure limit and temperature limit.

Ether

Ether (if equipped) is commonly used in cold-weather applications. Ether is flammable and poisonous.

Only use approved Ether canisters for the Ether dispensing system fitted to your machine, do not spray Ether manually into an engine, follow the correct cold engine starting procedures. Refer to the section in the Operation and Maintenance Manual with the label "Engine Starting" .

WARNING

Manually spraying Ether into an engine with a Diesel Particulate Filter (DPF) may result in the accumulation of Ether in the DPF and an explosion. This in conjunction with other factors may result in an injury or death.

Use ether in ventilated areas. Do not smoke while you are replacing an ether cylinder.

Do not store ether cylinders in living areas or in the operator compartment of a machine. Do not store ether cylinders in direct sunlight or in temperatures above 49° C (120.2° F). Keep ether cylinders away from open flames or sparks.

Dispose of used ether cylinders properly. Do not puncture an ether cylinder. Keep ether cylinders away from unauthorized personnel.

Fire Extinguisher

As an additional safety measure, keep a fire extinguisher on the machine.

Be familiar with the operation of the fire extinguisher. Inspect the fire extinguisher and service the fire extinguisher regularly. Follow the recommendations on the instruction plate.

Consider installation of an aftermarket Fire Suppression System, if the application and working conditions warrant the installation.

i07041871

Fire Safety

SMCS Code: 7000

Note: Locate secondary exits and how to use the secondary exits before you operate the machine.

Note: Locate fire extinguishers and how to use a fire extinguisher before you operate the machine.

If you find that you are involved in a machine fire, your safety and that of others on site are the top priority. The following actions should only be performed if the actions do not present a danger or risk to you and any nearby people. Assess the risk of personal injury and move away to a safe distance as soon as you feel unsafe.

Move the machine away from nearby combustible material such as fuel/oil stations, structures, trash, mulch, and timber.

Lower any implements and turn off the engine as soon as possible. If you leave the engine running, the engine will continue to feed a fire. The fire will be fed from any damaged hoses that are attached to the engine or pumps.

If possible, turn the battery disconnect switch to the OFF position. Disconnecting the battery will remove the ignition source in the event of an electrical short. Disconnecting the battery will eliminate a second ignition source if electrical wiring is damaged by the fire, resulting in a short circuit.

Notify emergency personnel of the fire and your location.

If your machine is equipped with a fire suppression system, follow the manufacturers procedure for activating the system.

Note: Fire suppression systems need to be regularly inspected by qualified personnel. You must be trained to operate the fire suppression system.

If you are unable to do anything else, shut off the machine before exiting. By shutting off the machine, fuels will not continue to be pumped into the fire.

If the fire grows out of control, be aware of the following risks:

- Tires on wheeled machines pose a risk of explosion as tires burn. Hot shrapnel and debris can be thrown great distances in an explosion.
- Tanks, accumulators, hoses, and fittings can rupture in a fire, spraying fuels and shrapnel over a large area.

- Remember that nearly all the fluids on the machine are flammable, including coolant and oils. Additionally, plastics, rubbers, fabrics, and resins in fiberglass panels are also flammable.

i01122596

Fire Extinguisher Location

SMCS Code: 7000; 7419

i05334251

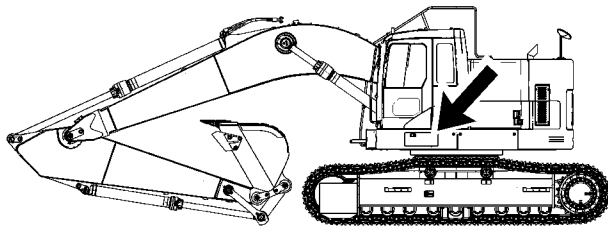

Illustration 57

g03379285

Make sure that a fire extinguisher is available. Be familiar with the operation of the fire extinguisher. Inspect the fire extinguisher and service the fire extinguisher regularly. Obey the recommendations on the instruction plate.

i01329108

Track Information

SMCS Code: 4170; 7000

Track adjusting systems use either grease or oil under high pressure to keep the track under tension.

Grease or oil under high pressure coming out of the relief valve can penetrate the body causing injury or death. Do not watch the relief valve to see if grease or oil is escaping. Watch the track or track adjustment cylinder to see if the track is being loosened.

The pins and bushings in a dry track pin joint can become very hot. It is possible to burn the fingers if there is more than brief contact with these components.

Electrical Storm Injury Prevention

SMCS Code: 7000

When lightning is striking in the vicinity of the machine, the operator should never attempt the following procedures:

- Mount the machine.
- Dismount the machine.

If you are in the operator's station during an electrical storm, stay in the operator's station. If you are on the ground during an electrical storm, stay away from the vicinity of the machine.

i00771840

Before Starting Engine

SMCS Code: 1000; 7000

Start the engine only from the operator compartment. Never short across the starter terminals or across the batteries. Shorting could damage the electrical system by bypassing the engine neutral start system.

Inspect the condition of the seat belt and of the mounting hardware. Replace any parts that are worn or damaged. Regardless of appearance, replace the seat belt after three years of use. Do not use a seat belt extension on a retractable seat belt.

Adjust the seat so that full pedal travel can be achieved with the operator's back against the back of the seat.

Make sure that the machine is equipped with a lighting system that is adequate for the job conditions. Make sure that all machine lights are working properly.

Before you start the engine and before you move the machine, make sure that no one is underneath the machine, around the machine, or on the machine. Make sure that the area is free of personnel.

i07746368

Visibility Information

SMCS Code: 7000

Before you start the machine, perform a walk-around inspection in order to ensure that there are no hazards around the machine.

While the machine is in operation, constantly survey the area around the machine in order to identify potential hazards as hazards become visible around the machine.

Safety Section Restricted Visibility

Your machine may be equipped with visual aids. Some examples of visual aids are Closed Circuit Television (CCTV) and mirrors. Before operating the machine, ensure that the visual aids are in proper working condition and that the visual aids are clean. Adjust the visual aids using the procedures that are located in this Operation and Maintenance Manual. If equipped, the Work Area Vision System shall be adjusted according to Operation and Maintenance Manual, SEBU8157, "Work Area Vision System". If equipped, the Cat Detect Object Detection shall be adjusted according to the Operation and Maintenance Manual, "Cat Detect Object Detection" for your machine.

It may not be possible to provide direct visibility on large machines to all areas around the machine. Appropriate job site organization is required in order to minimize hazards that are caused by restricted visibility. Job site organization is a collection of rules and procedures that coordinates machines and people that work together in the same area. Examples of job site organization include the following:

- Safety instructions
- Controlled patterns of machine movement and vehicle movement
- Workers that direct safe movement of traffic
- Restricted areas
- Operator training
- Warning symbols or warning signs on machines or on vehicles
- A system of communication
- Communication between workers and operators prior to approaching the machine

Modifications of the machine configuration by the user that result in a restriction of visibility shall be evaluated.

i06952725

Restricted Visibility

SMCS Code: 7000

The size and the configuration of this machine may result in areas that cannot be seen when the operator is seated. For restricted visibility areas, an appropriate job site organization must be utilized to minimize hazards of this restricted visibility. For more information regarding job site organization refer to Operation and Maintenance Manual, "Visibility Information".

Illustrations 58 - 60 provide an approximate visual indication of the areas at ground level inside a radius of 12 m (39 ft) from the operator of significant restricted visibility for various machine configurations. Refer to the correct illustration for your machine configuration. All restricted visibility areas less than 300 mm wide may not be shown. These illustrations do not indicate areas of restricted visibility for distances outside of the shown radius. The areas of restricted visibility shown in the illustrations are with the track and work tool of the machine in the Travel position. Illustration 61 shows the position of the work tool in the travel position. The Caterpillar authorized work tool that resulted in the largest visibility restriction was used.

Illustration 58 indicates restricted visibility areas at ground level inside the shown radius from the operator without the use of optional visual aids that may be optional for this product in some markets.

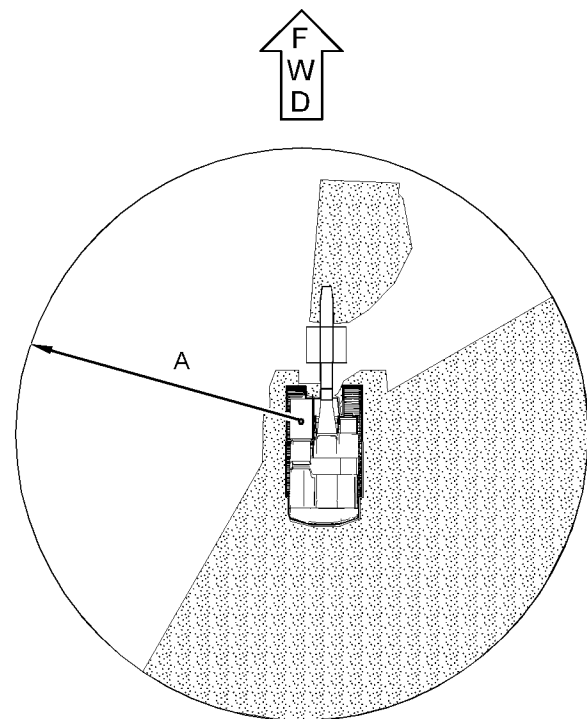

Illustration 58

g03866505

Top view of the machine, ground level visibility without use of optional visual aids

(A) 12 m (39 ft)

Note: The shaded areas indicate the approximate location of areas with significant restricted visibility.

Illustration 59 indicates restricted visibility areas at ground level inside the shown radius from the operator with the use of available rear camera, right side mirror, and left side mirror installed.

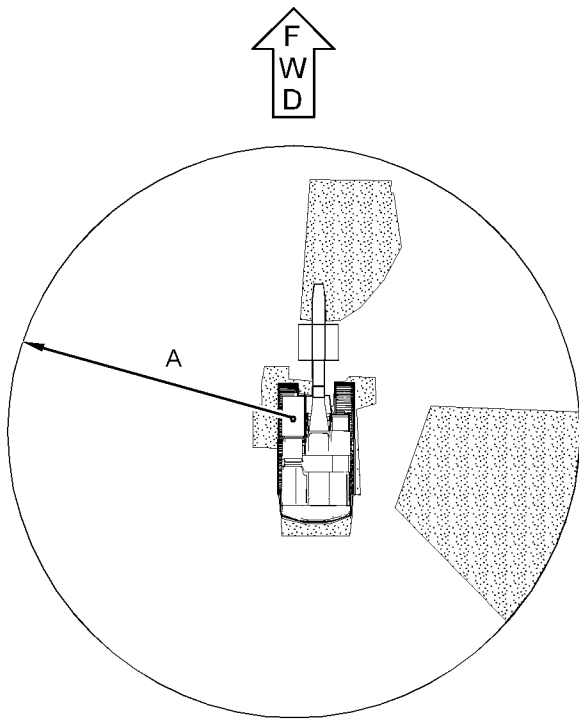

Illustration 59 g03866521
Top view of the machine, ground level visibility with available camera, left side mirror and right side mirror
(A) 12 m (39 ft)

Note: The shaded areas indicate the approximate location of areas with significant restricted visibility.

Illustration 60 indicates restricted visibility areas at ground level inside the shown radius from the operator with the use of available rear camera, right side camera (if equipped), left side mirrors installed.

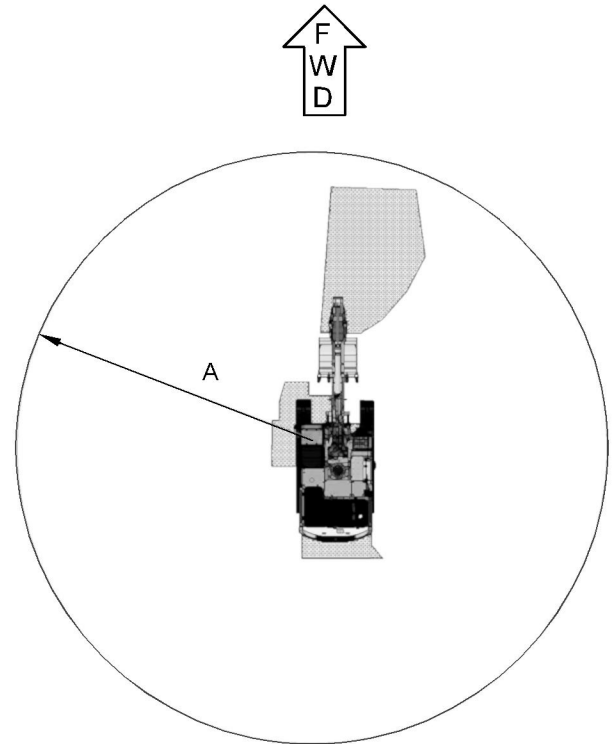

Illustration 60 g06034492
Top view of the machine, ground level visibility with available camera, left side mirror.
(A) 12 m (39 ft)

Note: The shaded areas indicate the approximate location of areas with significant restricted visibility.

Restricted visibility is measured when the front linkage of the machine is in the travel position. Illustration 61 shows the machine in the travel position.

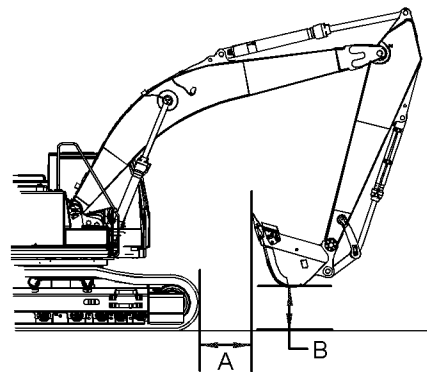

Illustration 61 g02155813
(A) 1 m (3.0 ft) from the front of the machine to the bucket
(B) 0.5 m (1.6 ft) from ground level

i03562260

i04159629

Engine Starting

SMCS Code: 1000; 7000

If a warning tag is attached to the engine start switch or to the controls, do not start the engine. Also, do not move any controls.

Make sure that you are seated before you start the engine.

Move all hydraulic controls to the HOLD position before you start the engine. Move the hydraulic lockout control to the LOCKED position. For further details on this procedure, refer to Operation and Maintenance Manual, "Operator Controls".

Diesel engine exhaust contains products of combustion which can be harmful to your health. Always run the engine in a well ventilated area. If you are in an enclosed area, vent the exhaust to the outside.

Briefly sound the horn before you start the engine.

i01340061

Before Operation

SMCS Code: 7000

Clear all personnel from the machine and from the area.

Clear all obstacles from the machine's path. Beware of hazards (wires, ditches, etc).

Be sure that all windows are clean. Secure the doors and the windows in the open position or in the shut position.

Adjust the rearview mirrors (if equipped) for the best visibility close to the machine. Make sure that the horn, the travel alarm (if equipped), and all other warning devices are working properly.

Fasten the seat belt securely.

Warm up the engine and the hydraulic oil before operating the machine.

Before moving the machine, check the position of the undercarriage. The normal travel position is with the idler wheels to the front under the cab and the drive sprockets to the rear. When the undercarriage is in the reversed position, the directional controls must be operated in opposite directions.

Work Tools

SMCS Code: 6700

Only use work tools that are recommended by Caterpillar for use on Cat machines.

Use of work tools, including buckets, which are outside of Caterpillar's recommendations or specifications for weight, dimensions, flows, pressures, and so on, may result in less-than-optimal vehicle performance, including but not limited to reductions in production, stability, reliability, and component durability. Caterpillar recommends appropriate work tools for our machines to maximize the value our customers receive from our products. Caterpillar understands that special circumstances may lead a customer to use tools outside of our specifications. In these cases, customers must be aware that such choices can reduce vehicle performance and will affect their ability to claim warranty in the event of what a customer may perceive as a premature failure.

Work tools and work tool control systems, that are compatible with your Cat machine, are required for safe machine operation and/or reliable machine operation. If you are in doubt about the compatibility of a particular work tool with your machine, consult your Cat dealer.

Make sure that all necessary guarding is in place on the host machine and on the work tool.

Keep all windows and doors closed on the host machine. A polycarbonate shield must be used when the host machine is not equipped with windows and when a work tool could throw debris.

Do not exceed the maximum operating weight that is listed on the ROPS certification.

If your machine is equipped with an extendable stick, install the transport pin when you are using the following work tools: hydraulic hammers, augers and compactors

Always wear protective glasses. Always wear the protective equipment that is recommended in the operation manual for the work tool. Wear any other protective equipment that is required for the operating environment.

To prevent personnel from being struck by flying objects, ensure that all personnel are out of the work area.

While you are performing any maintenance, any testing, or any adjustments to the work tool stay clear of the following areas: cutting edges, pinching surfaces and crushing surfaces.

Never use the work tool for a work platform.

i07742495

Operation

SMCS Code: 7000

Machine Operating Temperature Range

The machine must function satisfactorily in the anticipated ambient temperature limits that are encountered during operation. The standard machine configuration is intended for use within an ambient temperature range of $-18\text{ }^{\circ}\text{C}$ ($0\text{ }^{\circ}\text{F}$) to $43\text{ }^{\circ}\text{C}$ ($109\text{ }^{\circ}\text{F}$). Special configurations for different ambient temperatures may be available. Consult your Cat dealer for additional information on special configurations of your machine.

Limiting Conditions and Criteria

Limiting conditions are immediate issues with this machine that must be addressed prior to continuing operation.

The Operation and Maintenance Manual, Safety Section describes limiting condition criteria for replacing items such as safety messages, seat belt and mounting hardware, lines, tubes, hoses, battery cables and related parts, electrical wires, and repairing any fluid leak.

The Operation and Maintenance Manual, Maintenance Interval Schedule describes limiting condition criteria that require repair or replacement for items (if equipped) such as alarms, horns, braking system, steering system, and rollover protective structures.

The Operation and Maintenance Manual, Monitoring System (if equipped) provides information on limiting condition criteria, including a Warning Category 3 that requires immediate shutdown of the engine.

The following table provides summary information on several limiting conditions found in this Operation and Maintenance Manual. The table provides criteria and required action for the limiting conditions listed. Each System or Component in this table, together with the respective limiting condition, describes a potential critical failure that must be addressed. Not addressing limiting conditions with required actions may, in conjunction with other factors or circumstances, result in a risk of personal injury or death. If an accident occurs, notify emergency personnel and provide location and description of accident.

Safety Section
Operation

Table 1

System or Component Name	Limiting Condition	Criteria for Action	Required Action
Line, tubes, and hoses	End fittings are damaged or leaking. Outer coverings are chafed or cut. Wires are exposed. Outer coverings are swelling or ballooning. Flexible parts of the hoses are kinked. Outer covers have exposed embedded armoring. End fittings are displaced.	Visible corrosion, loose, or damaged lines, tubes, or hoses. Visible fluid leaks.	Immediately repair any lines, tubes, or hoses that are corroded, loose, or damaged. Immediately repair any leaks as these may provide fuel for fires.
Electrical Wiring	Signs of fraying, abrasion, cracking, discoloration, cuts on the insulation	Visible damage to electrical wiring	Immediately replace damaged wiring
Battery cable(s)	Signs of fraying, abrasion, cracking, discoloration, cuts on the insulation of the cable, fouling, corroded terminals, damaged terminals, and loose terminals	Visible damage to battery cable(s)	Immediately replace damaged battery cables
Operator Protective Structure	Structures that are bent, cracked, or loose. Loose, missing, or damaged bolts.	Visible damage to structure. Loose, missing, or damaged bolts.	Do not operate machine with damaged structure or loose, missing, or damaged bolts. Contact your Cat dealer for inspection and repair or replacement options.
Seat Belt	Worn or damaged seat belt or mounting hardware	Visible wear or damage	Immediately replace parts that are worn or damaged.
Seat Belt	Age of seat belt	Three years after date of installation	Replace seat belt three years after date of installation
Safety Messages	Appearance of safety message	Damage to safety messages making them illegible	Replace the illustrations if illegible.
Audible Warning Device(s) (if equipped)	Sound level of audible warning	Reduced or no audible warning present	Immediately repair or replace audible warning devices not working properly.
Camera(s) (if equipped)	Dirt or debris on camera lens	Dirt or debris obstructing camera view	Clean camera before operating machine.
Cab Windows (if equipped)	Dirt, debris, or damaged windows	Dirt or debris obstructing operator visibility. Any damaged windows.	Clean windows before operating machine. Repair or replace damaged windows before operating machine.
Mirrors (if equipped)	Dirt, debris, or damaged mirror	Dirt or debris obstructing operator visibility. Any damaged mirrors.	Clean mirrors before operating machine. Repair or replace damaged mirrors before operating machine.
Braking System	Inadequate braking performance	System does not pass Braking System - Test(s) included in Maintenance Section or in the Testing and Adjusting Manual	Contact your Cat dealer to inspect and, if necessary, repair the brake system.
Cooling System	The coolant temperature is too high.	Monitoring System displays Warning Category 3	Stop the engine immediately. Check the coolant level and check the radiator for debris. Refer to Operation and Maintenance Manual, Cooling System Coolant Level - Check. Check the fan drive belts for the water pump. Refer to Operation and Maintenance Manual, Belts - Inspect/Adjust/ Replace. Make any necessary repairs.
Engine Oil System	A problem has been detected with the engine oil pressure.	Monitoring System displays Warning Category 3	If the warning stays on during low idle, stop the engine and check the engine oil level. Perform any necessary repairs as soon as possible.
Engine system	An engine fault has been detected by the engine ECM.	Monitoring System displays Warning Category 3	Stop the engine immediately. Contact your Cat dealer for service.
Fuel System	A problem has been detected with the fuel system.	Monitoring System displays Warning Category 3	Stop the engine. Determine the cause of the fault and perform any necessary repairs.
Hydraulic Oil System	The hydraulic oil temperature is too high.	Monitoring System displays Warning Category 3	Stop the engine immediately. Check the hydraulic oil level and check the hydraulic oil cooler for debris. Perform any necessary repairs as soon as possible.

(continued)

(Table 1, contd)

System or Component Name	Limiting Condition	Criteria for Action	Required Action
Steering System	A problem has been detected with the steering system. (If equipped with steering system monitoring.)	Monitoring System displays Warning Category 3	Move machine to a safe location and stop the engine immediately. Contact your Cat dealer to inspect and, if necessary, repair the steering system.
Overall Machine	Machine service is required.	Monitoring System displays Warning Category 3	Stop the engine immediately. Contact your Cat dealer for service.

Machine Operation

Only operate the machine while you are in a seat. The seat belt must be fastened while you operate the machine. Only operate the controls while the engine is running.

Check for proper operation of all controls and of all protective devices while you operate the machine slowly in an open area.

When the machine is moving watch the clearance of the boom. Uneven ground can cause the boom to move in all directions.

Make sure that no personnel will be endangered before you move the machine. Do not allow riders on the machine unless the machine has an additional seat with a seat belt.

Report any machine damage that was noted during machine operation. Make any necessary repairs.

Never use the work tool for a work platform.

Hold attachments approximately 40 cm (15 inches) above ground level while you drive the machine. Do not drive the machine close to an overhang, to the edge of a cliff, or to the edge of an excavation.

If the machine begins to sideslip on a grade, immediately dump the load and turn the machine downhill.

Be careful to avoid any ground condition which could cause the machine to tip. Tipping can occur when you work on hills, on banks, or on slopes. Tipping can also occur when you cross ditches, ridges, or other unexpected obstructions.

When possible, operate the machine up slopes and down slopes with the final drive sprockets facing down the slope. Avoid operating the machine across the slope. Place the heaviest end of the machine uphill when you are working on an incline.

Keep the machine under control. Do not overload the machine beyond capacity.

Avoid changing the direction of travel on a slope. Changing the direction of travel on a slope could result in tipping or side slipping of the machine.

Bring the load close to the machine before traveling any distances.

Bring the load close to the machine before swinging the load.

Lifting capacity decreases as the load is moved further from the machine.

Make sure that the towing eyes and the towing devices are adequate for your needs.

Only connect trailing equipment to a drawbar or to a hitch.

Never straddle a wire cable. Never allow other personnel to straddle a wire cable.

When you maneuver in order to connect the equipment, make sure that no personnel are between the machine and trailing equipment. Block up the hitch of the trailing equipment in order to align the equipment with the drawbar.

Check the local regulations, state codes, and/or directives of the job site for a specific minimum distance from obstacles.

Before you operate the machine, check with local utilities for the locations of underground pipes and for the locations of buried cables.

Know the maximum dimensions of your machine.

Watch the load at all times.

Do not operate the machine without the counterweight. The machine can tip when the boom is over the side.

The clamshell, the grapple, or the magnet can swing in all directions. Move the joysticks in a continuous motion. Failure to move the joysticks in a continuous motion can cause the clamshell, the grapple, or the magnet to swing into the cab or into a person in the work area. This will result in personal injury.

Certain machine front linkage combinations (boom, stick, quick coupler, work tool) can allow the work tool to contact the machine undercarriage, swing frame, boom, boom hydraulic cylinder and or the cab. Be aware of the position of the work tool while you operate the machine.

Shut down the machine until damaged or non-functioning visibility aid(s) is repaired (if applicable) or until appropriate job site organization is used to minimize hazards that are caused by any resulting restricted visibility.

Machine Operation when the Machine is not Completely Assembled

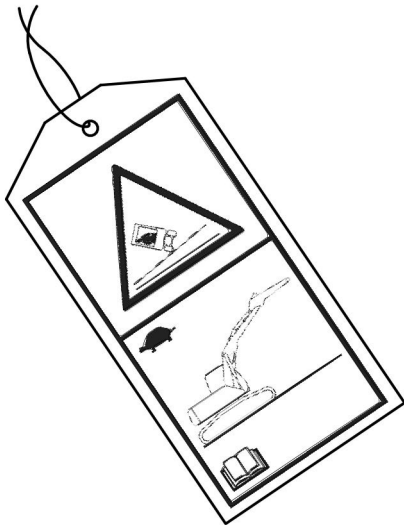

Illustration 62

g02202544

Attach the tag to the controls of the machine. When the tag is attached to the controls, operate the machine as described below.

If the machine needs to be operated without the boom, stick, and/or counterweight being installed, the machine should be operated slowly on flat, stable ground or pavement by qualified operators. Avoid any machine operations which could affect machine stability, including the swing function. The ROPS structural certification depends on the support of the boom, stick, and counterweight in the event of a machine tip over or a machine rollover incident.

i06299648

Engine Stopping

SMCS Code: 1000; 7000

Do not stop the engine immediately after the machine has been operated under load. Stopping the engine immediately can cause overheating and accelerated wear of engine components.

After the machine is parked and the parking brake is engaged, allow the engine to run at low idle for 5 minutes before shutdown. Running the engine allows hot areas of the engine to cool gradually.

i07262981

Lifting Objects

SMCS Code: 7000

There may be local regulations and/or government regulations that govern the use of machines which lift heavy objects. Obey all local and government regulations.

If this machine is used to lift objects within an area that is controlled by the European Directive "2006/42/EC", the machine must be equipped with a boom lowering control valve, a stick lowering control valve, and an overload warning device.

i07749631

Demolition

SMCS Code: 6700

There maybe local regulations and/or government regulations that govern the use of machines which are designed and used as demolition machinery.

Note: Obey all local and government regulations.

Demolition machinery is designed for demolishing by pushing or pulling, or fragmenting. Demolition is done by crushing or shearing, buildings and/or other civil engineering structures and component parts and/or separating the resultant debris.

If this machine is used for demolition within an area that is controlled by the European Directive 2006/42/EC, the machine must be equipped with:

- Rollover Protective Structure (ROPS, not required for demolition excavators)
- Boom Lowering Control Valve (BLCV) / Stick Lowering Control Valve (SLCV)
- Top Guard / Front Guard
- Bottom / Motor / Swivel Guard
- EN 356 class P5A front window glass
- If a roof window is used to provide visibility to the working area, then roof window shall be equipped with motorized windscreen wipers and washers.

Demolition applications may generate flying debris. Ensure that there are no personnel in the area around the machine where flying debris may travel.

Demolition applications may generate airborne dust that can be hazardous to your health. If you operate the machine in a dust generating applications, use appropriate safeguarding or adequate ventilation to minimize risk.

i07393520

Parking

SMCS Code: 7000

The hydraulic system controls remain pressurized if the accumulator is charged. This condition is true even when the engine is not running. The hydraulic control system pressure should decrease in a short time (approximately 1 minute). While the hydraulic controls maintain a charge, the hydraulic work tools and machine controls remain functional.

There can be residual pressure within the hydraulic system even when the accumulator is empty. Refer to this Operation and Maintenance Manual, "System Pressure Release" before any service is performed to the hydraulic system.

Machine movement that is sudden and unexpected will occur if any of the controls are moved. Machine movement that is sudden and unexpected, can cause personal injury or death.

Always move the hydraulic lockout control to the LOCKED position before you shut off the engine or immediately after the engine stops running.

Park the machine on a hard, level surface. If you must park the machine on a grade, chock the tracks of the machine.

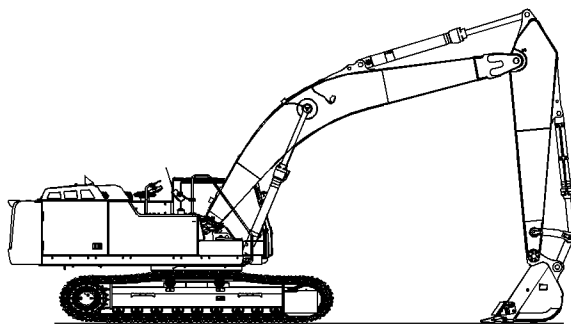

Illustration 63

g02280104

Place the machine in the servicing position.

Note: Make sure that all work tools are in the recommended servicing position before servicing the machine.

Move the hydraulic lockout control to the LOCKED position.

Stop the engine.

Turn the engine start switch to the OFF position and remove the engine start switch key.

Turn the battery disconnect switch to the OFF position.

Note: Do not turn the battery disconnect switch OFF until the "Wait to Disconnect Lamp" has turned off. If the battery disconnect switch is turned off before the lamp has shut off, the DEF system will not purge. DEF could freeze and damage the pump and lines.

Remove the disconnect switch key if you do not operate the machine for an extended period. This will prevent drainage of the battery. A battery short circuit, any current draw from certain components, and vandalism can cause drainage of the battery.

Install barriers or lighting as required to prevent interference in road traffic.

Select places free of danger by flooding and other water damage.

i07746366

Slope Operation

SMCS Code: 7000

Machines that are operating safely in various applications depend on these criteria: the machine model, configuration, machine maintenance, operating speed of the machine, conditions of the terrain, fluid levels, and tire inflation pressures. The most important criteria are the skill and judgment of the operator.

A well trained operator that follows the instructions in the Operation and Maintenance Manual has the greatest impact on stability. Operator training provides a person with the following abilities: observation of working and environmental conditions, feel for the machine, identification of potential hazards and operating the machine safely by making appropriate decisions.

When you work on side hills and when you work on slopes, consider the following important points:

Speed of travel – At higher speeds, forces of inertia tend to make the machine less stable.

Roughness of terrain or surface – The machine may be less stable with uneven terrain.

Direction of travel – Avoid operating the machine across the slope. When possible, operate the machine up the slopes and operate the machine down the slopes. Place the heaviest end of the machine uphill when you are working on an incline.

Mounted equipment – Balance of the machine may be impeded by the following components: equipment that is mounted on the machine, machine configuration, weights, and counterweights.

Nature of surface – Ground that has been newly filled with earth may collapse from the weight of the machine.

i01329161

Surface material – Rocks and moisture of the surface material may drastically affect the machine's traction and machine's stability. Rocky surfaces may promote side slipping of the machine.

Slippage due to excessive loads – This may cause downhill tracks or downhill tires to dig into the ground, which will increase the angle of the machine.

Width of tracks or tires – Narrower tracks or narrower tires further increase the digging into the ground which causes the machine to be less stable.

Implements attached to the drawbar – This may decrease the weight on the uphill tracks. This may also decrease the weight on the uphill tires. The decreased weight will cause the machine to be less stable.

Height of the working load of the machine – When the working loads are in higher positions, the stability of the machine is reduced.

Operated equipment – Be aware of performance features of the equipment in operation and the effects on machine stability.

Operating techniques – Keep all attachments or pulled loads low to the ground for optimum stability.

Machine systems have limitations on slopes – Slopes can affect the proper function and operation of the various machine systems. These machine systems are needed for machine control.

Note: Operators with lots of experience and proper equipment for specific applications are also required. Safe operation on steep slopes may also require special machine maintenance. Refer to Lubricant Viscosities and Refill Capacities in this manual for the proper fluid level requirements and intended machine use. Fluids must be at the correct levels to ensure that systems will operate properly on a slope.

Equipment Lowering with Engine Stopped

SMCS Code: 7000-II

Before lowering any equipment with the engine stopped, clear the area around the equipment of all personnel. The procedure to use will vary with the type of equipment to be lowered. Keep in mind most systems use a high pressure fluid or air to raise or lower equipment. The procedure will cause high pressure air, hydraulic, or some other media to be released in order to lower the equipment. Wear appropriate personal protective equipment and follow the established procedure in the Operation and Maintenance Manual, "Equipment Lowering with Engine Stopped" in the Operation Section of the manual.

i06749675

Sound Information and Vibration Information

SMCS Code: 7000

Sound Level Information

The declared dynamic operator sound pressure level is 79 dB(A) when "ISO 6396: 2008" is used to measure the value for an enclosed cab. The measurement was conducted at 70% of the maximum engine cooling fan speed. The sound level may vary at different engine cooling fan speeds. The measurement was conducted with the cab doors and the cab windows closed. The cab was properly installed and maintained.

Hearing protection may be needed when the machine is operated with an open operator station for extended periods or in a noisy environment. Hearing protection may be needed when the machine is operated with a cab that is not properly maintained, or when the doors and windows are open for extended periods or in a noisy environment.

Sound Level Information for Machines in European Union Countries and in Countries that Adopt the "EU Directives"

The declared exterior sound power level is 104 L_{WA} when the value is measured according to the dynamic test procedures and conditions that are specified in "ISO 6395:2008". The measurement was conducted at 70% of the maximum engine cooling fan speed. The sound level may vary at different engine cooling fan speeds.

The declared dynamic operator sound pressure level is 79 dB(A) when "ISO 6396: 2008" is used to measure the value for an enclosed cab. The measurement was conducted at 70% of the maximum engine cooling fan speed. The sound level may vary at different engine cooling fan speeds. The measurement was conducted with the cab doors and the cab windows closed. The cab was properly installed and maintained.

“The European Union Physical Agents (Vibration) Directive 2002/44/EC”

Vibration Data for Track-Type Excavator

Information Concerning Hand/Arm Vibration Level

When the machine is operated according to the intended use, the hand/arm vibration of this machine is below 2.5 m/s².

Information Concerning Whole Body Vibration Level

This section provides vibration data and a method for estimating the vibration level for track-type excavators.

Note: Vibration levels are influenced by many different parameters. Many items are listed below.

- Operator training, behavior, mode and stress
- Job site organization, preparation, environment, weather and material
- Machine type, quality of the seat, quality of the suspension system, attachments and condition of the equipment

It is not possible to get precise vibration levels for this machine. The expected vibration levels can be estimated with the information in Table 2 in order to calculate the daily vibration exposure. A simple evaluation of the machine application can be used.

Estimate the vibration levels for the three vibration directions. For typical operating conditions, use the average vibration levels as the estimated level. With an experienced operator and smooth terrain, subtract the Scenario Factors from the average vibration level in order to obtain the estimated vibration level. For aggressive operations and severe terrain, add the Scenario Factors to the average vibration level in order to obtain the estimated vibration level.

Note: All vibration levels are in meter per second squared.

Table 2

"ISO Reference Table A - Equivalent vibration levels of whole body vibration emission for earthmoving equipment."							
Machine Type	Typical Operating Activity	Vibration Levels			Scenario Factors		
		X axis	Y axis	Z axis	X axis	Y axis	Z axis
Track-Type Excavator	excavating	0,44	0,27	0,30	0,24	0,16	0,17
	hydraulic breaker application	0,53	0,31	0,55	0,30	0,18	0,28
	mining application	0,65	0,42	0,61	0,21	0,15	0,32
	transfer	0,48	0,32	0,79	0,19	0,20	0,23

Note: Refer to "ISO/TR 25398 Mechanical Vibration - Guideline for the assessment of exposure to whole body vibration of ride on operated earthmoving machines" for more information about vibration. This publication uses data that is measured by international institutes, organizations, and manufacturers. This document provides information about the whole body exposure of operators of earthmoving equipment. Refer to Operation and Maintenance Manual, SEBU8257, "The European Union Physical Agents (Vibration) Directive 2002/44/EC" for more information about machine vibration levels.

The Caterpillar suspension seat meets the criteria of "ISO 7096". This represents vertical vibration level under severe operating conditions.

Guidelines for Reducing Vibration Levels on Earthmoving Equipment

Properly adjust machines. Properly maintain machines. Operate machines smoothly. Maintain the conditions of the terrain. The following guidelines can help reduce the whole body vibration level:

1. Use the right type and size of machine, equipment, and attachments.
2. Maintain machines according to the manufacturers recommendations.
 - a. Tire pressures
 - b. Brake and steering systems
 - c. Controls, hydraulic system, and linkages
3. Keep the terrain in good condition.
 - a. Remove any large rocks or obstacles.
 - b. Fill any ditches and holes.
 - c. Provide machines and schedule time in order to maintain the conditions of the terrain.
4. Use a seat that meets "ISO 7096". Keep the seat maintained and adjusted.
 - a. Adjust the seat and suspension for the weight and the size of the operator.
 - b. Inspect and maintain the seat suspension and adjustment mechanisms.
5. Perform the following operations smoothly.
 - a. Steer
 - b. Brake
 - c. Accelerate.
 - d. Shift the gears.
6. Move the attachments smoothly.
7. Adjust the machine speed and the route in order to minimize the vibration level.
 - a. Drive around obstacles and rough terrain.
 - b. Slow down when traveling over rough terrain.
8. Minimize vibrations for a long work cycle or a long travel distance.
 - a. Use machines that are equipped with suspension systems.
 - b. Use the ride control system on track-type excavators.
 - c. If no ride control system is available, reduce speed in order to prevent bounce.
 - d. Haul the machines between workplaces.
9. Less operator comfort may be caused by other risk factors. The following guidelines can be effective in order to provide better operator comfort:
 - a. Adjust the seat and adjust the controls in order to achieve good posture.
 - b. Adjust the mirrors in order to minimize twisted posture.
 - c. Provide breaks in order to reduce long periods of sitting.
 - d. Avoid jumping from the cab.
 - e. Minimize repeated handling of loads and lifting of loads.

- f. Minimize any shocks and impacts during sports and leisure activities.

i07746359

Sources

The vibration information and calculation procedure is based on "ISO/TR 25398 Mechanical Vibration - Guideline for the assessment of exposure to whole body vibration of ride on operated earthmoving machines". Harmonized data is measured by international institutes, organizations, and manufacturers.

This literature provides information about assessing the whole body vibration exposure of operators of earthmoving equipment. The method is based on measured vibration emission under real working conditions for all machines.

Check the original directive. This document summarizes part of the content of the applicable law. This document is not meant to substitute the original sources. Other parts of these documents are based on information from the United Kingdom Health and Safety Executive.

Refer to Operation and Maintenance Manual, SEBU8257, "The European Union Physical Agents (Vibration) Directive 2002/44/EC" for more information about vibration.

Consult your local Caterpillar dealer for more information about machine features that minimize vibration levels. Consult your local Caterpillar dealer about safe machine operation.

Use the following web site in order to find your local dealer:

Caterpillar, Inc.
www.cat.com

i07746362

Operator Station

SMCS Code: 7300; 7301; 7325

Any modifications to the inside of the operator station should not project into the operator space or into the space for the companion seat (if equipped). The addition of a radio, fire extinguisher, and other equipment must be installed so that the defined operator space and the space for the companion seat (if equipped) is maintained. Any item that is brought into the cab should not project into the defined operator space or the space for the companion seat (if equipped). A lunch box or other loose items must be secured. Objects must not pose an impact hazard in rough terrain or in the event of a rollover.

Guards (Operator Protection)

SMCS Code: 7000; 7150

There are different types of guards that are used to protect the operator. The machine and the machine application determine the type of guard that should be used.

A daily inspection of the guards is required in order to check for structures that are bent, cracked, or loose. Never operate a machine with a damaged structure.

The operator becomes exposed to a hazardous situation if the machine is used improperly or if poor operating techniques are used. This situation can occur even though a machine is equipped with an appropriate protective guard. Follow the established operating procedures that are recommended for your machine.

Rollover Protective Structure (ROPS), Falling Object Protective Structure (FOPS) or Tip Over Protection Structure (TOPS)

The ROPS/FOPS Structure (if equipped) on your machine is specifically designed, tested and certified for that machine. Any alteration or any modification to the ROPS/FOPS Structure could weaken the structure. This places the operator into an unprotected environment. Modifications or attachments that cause the machine to exceed the weight that is stamped on the certification plate also place the operator into an unprotected environment. Excessive weight may inhibit the brake performance, the steering performance and the ROPS. The protection that is offered by the ROPS/FOPS Structure will be impaired if the ROPS/FOPS Structure has structural damage. Damage to the structure can be caused by an overturn, a falling object, a collision, etc.

Do not mount items (fire extinguishers, first aid kits, work lights, etc) by welding brackets to the ROPS/ FOPS Structure or by drilling holes in the ROPS/ FOPS Structure. Welding brackets or drilling holes in the ROPS/FOPS Structures can weaken the structures. Consult your Cat dealer for mounting guidelines.

The Tip Over Protection Structure (TOPS) is another type of guard that is used on mini hydraulic excavators. This structure protects the operator in the event of a tipover. The same guidelines for the inspection, the maintenance and the modification of the ROPS/FOPS Structure are required for the Tip Over Protection Structure.

Other Guards (If Equipped)

Protection from flying objects and/or falling objects is required for special applications. Logging applications and demolition applications are two examples that require special protection.

A front guard needs to be installed when a work tool that creates flying objects is used. Mesh front guards that are approved by Caterpillar or polycarbonate front guards that are approved by Caterpillar are available for machines with a cab or an open canopy. On machines that are equipped with cabs, the windows should also be closed. Safety glasses are recommended when flying hazards exist for machines with cabs and machines with open canopies.

If the work material extends above the cab, top guards and front guards should be used. Typical examples of this type of application are listed below:

- Demolition applications
- Rock quarries
- Forestry products

Additional guards may be required for specific applications or work tools. The Operation and Maintenance Manual for your machine or your work tool will provide specific requirements for the guards. Refer to Operation Maintenance manual, "Demolition" for additional information. Consult your Cat dealer for additional information.

Product Information Section

General Information

i06989564

Specifications

SMCS Code: 7000

Basic machine specifications are listed below.

Intended Use

The intended use of this machine is for excavating with a bucket or working with approved work tools. The machine should be operated with the undercarriage in a stationary position since the upper structure is normally capable of 360 degree swing with mounted equipment. This machine can be used in object handling applications that are within the lift capacity of the machine. When this machine is used in object handling applications, ensure that the machine is properly configured and operated properly. Obey any local governmental regulations and regional governmental regulations. Only lift objects from approved lifting points and with approved lifting devices.

Application/Configuration Restrictions

The maximum travel operating slope for machine lubrication is 35 degrees.

The operator station is ROPS certified up to a mass of 40726 kg (89801 lb) per ISO 12117-2:2008.

Specification Data

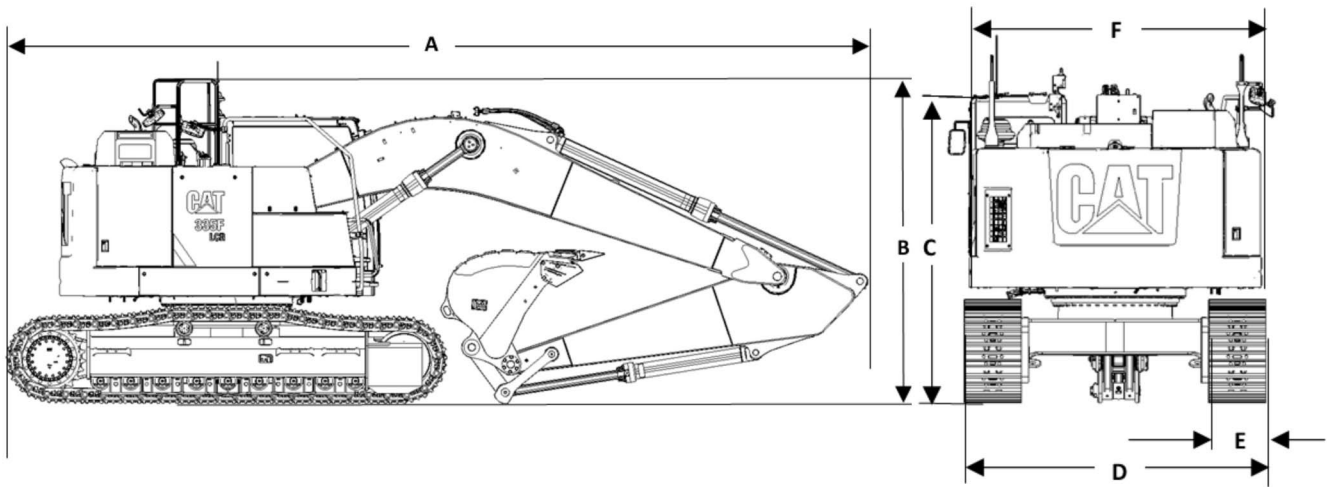
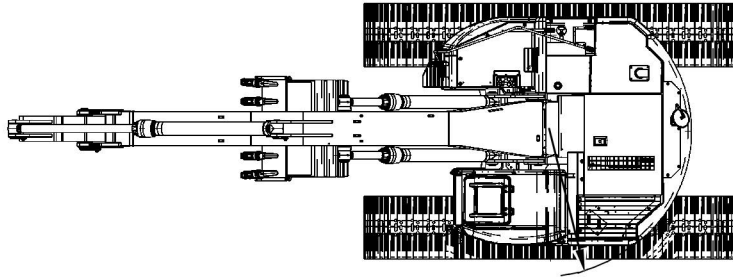

Illustration 64

g03379291

335F LCR Reach Boom

Table 3

335F L Reach Boom Excavator ⁽¹⁾	
	3.75 m (12 ft 3 inch) Stick
	1.3 m ³ (1.9 yd ³) Bucket
Overall Length (A)	9870 mm (32 ft 4 inch)

(continued)

(Table 3, contd)

Overall Height (B)	3650 mm (12 ft 1 inch)		
Height of Cab (C)	3260 mm (10 ft 7 inch)		
Overall Width (D)	3190 mm (10 ft 5 inch)	3290 mm (10 ft 8 inch)	3440 mm (11 ft 3 inch)
Track Shoe Width (E)	600 mm (24 inch)Track Shoe	700 mm (28 inch)Track Shoe	800 mm (31 inch)Track Shoe
Width Of Upper Structure (F)	3090 mm (10 ft 1 inch)		

(1) 10% Fuel

Table 4

335F L Reach Boom Excavator⁽¹⁾			
	3.2 m (10 ft 5 inch) Stick		
	1.5 m³ (2.2 yd³) Bucket		
Overall Length (A)	9820 mm (32 ft 2 inch)		
Overall Height (B)	3450 mm (11 ft 7 inch)		
Height of Cab (C)	3260 mm (10 ft 7 inch)		
Overall Width (D)	3190 mm (10 ft 5 inch)	3290 mm (10 ft 8 inch)	3440 mm (11 ft 3 inch)
Track Shoe Width (E)	600 mm (24 inch)Track Shoe	700 mm (28 inch)Track Shoe	800 mm (31 inch)Track Shoe
Width Of Upper Structure (F)	3090 mm (10 ft 1 inch)		

(1) 10% Fuel

Table 5

335F L Reach Boom Excavator⁽¹⁾			
	2.65 m (8 ft 7 inch) Stick		
	1.7 m³ (2.5yd³) Bucket		
Overall Length (A)	9850 mm (32 ft 3 inch)		
Overall Height (B)	3540 mm (11 ft 7 inch)		
Height of Cab (C)	3260 mm (10 ft 7 inch)		
Overall Width (D)	3190 mm (10 ft 5 inch)	3290 mm (10 ft 8 inch)	3440 mm (11 ft 3 inch)
Track Shoe Width (E)	600 mm (24 inch)Track Shoe	700 mm (28 inch)Track Shoe	800 mm (31 inch)Track Shoe
Width Of Upper Structure (F)	3090 mm (10 ft 1 inch)		

(1) 10% Fuel

Working Ranges

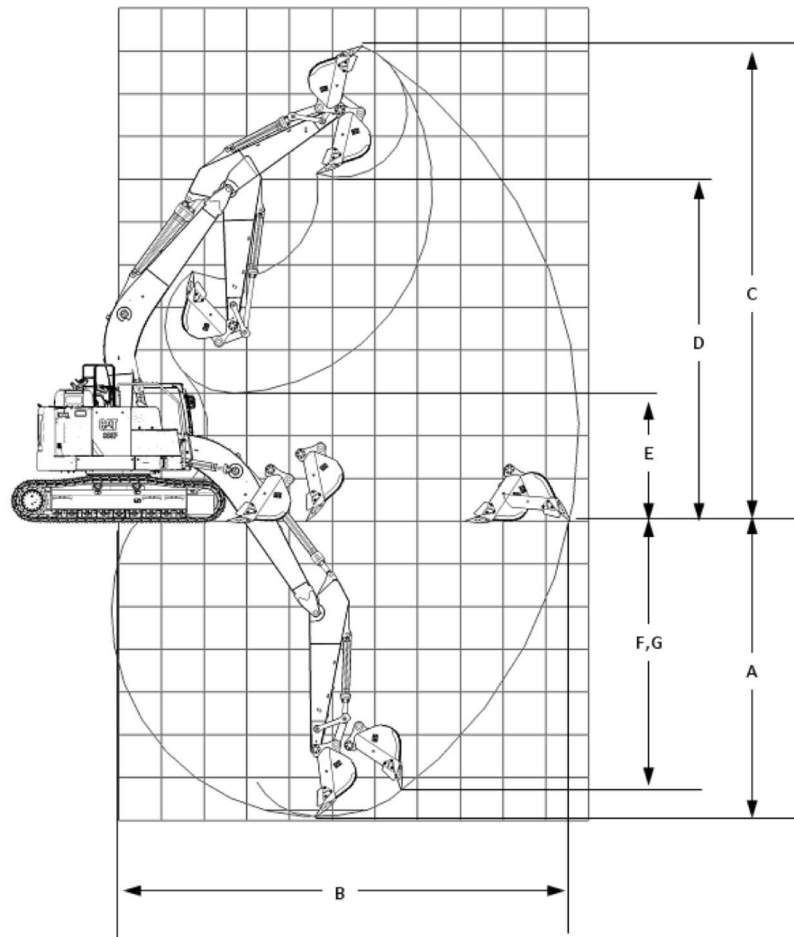

Illustration 65

g03380021

Table 6

335F L Excavator			
	6.15 m (20 ft 2 inch) Reach Boom		
Stick	3.2 m (10 ft 6 inch) Stick	2.65 m (8 ft 8 inch) Stick	3.75 m (12 ft 3 inch) Stick
Bucket	1.51 m ³ (2.2 yd ³)	1.71 m ³ (2.5 yd ³)	1.3 m ³ (1.9 yd ³)
Maximum Digging Depth (A)	6990 mm (22 ft 9 inch)	6440 mm (21 ft 1 inch)	7540 mm (24 ft 5 inch)
Maximum Reach at Ground Level (B)	10640 mm (34 ft 8 inch)	10160 mm (33 ft 3 inch)	11140 mm (36 ft 7 inch)
Maximum Cutting Height (C)	11150 mm (36 ft 6 inch)	10950 mm (35 ft 9 inch)	11410 mm (37 ft 5 inch)
Minimum Loading Height (D)	7970 mm (26 ft 1 inch)	7750 mm (25 ft 4 inch)	8240 mm (27 ft)
Minimum Loading Height (E)	2920 mm (9 ft 6 inch)	3480 mm (11 ft 4 inch)	2370 mm (7 ft 9 inch)
Maximum Cutting Depth (F)	6830 mm (22 ft 4 inch)	6260 mm (20 ft 5 inch)	7400 mm (24 ft 3 inch)

(continued)

(Table 6, contd)

Maximum Depth Cut (G) (2440 mm Level Bottom)	6830 mm (22 ft 4 inch)	6260 mm (20 ft 5 inch)	7400 mm (24 ft 3 inch)
Maximum Digging Depth (H) (Vertical wall)	5770 mm (18 ft 9 inch)	5460 mm (17 ft 9 inch)	6210 mm (20 ft 4 inch)

i05960472

Boom/Stick/Bucket Combinations

SMCS Code: 6000; 6700

This machine can be equipped with a large variety of boom-stick-bucket combinations in order to meet the needs of various applications.

Buckets are grouped into families (B and C) according to the capacity of the bucket. Generally, use a bucket with a smaller capacity when you are using a longer stick and/or a longer boom. Conversely, use a bucket with a larger capacity when you are using a shorter stick and/or a shorter boom. This rule ensures better machine stability and protection against structural machine damage.

The following tables show various compatible boom-stick-bucket combinations. Select an optimum combination according to the working conditions and according to the type of work that is being done.

ANZ

Table 7

335F Excavator with 6.15 m (20 ft 2 inch) Reach Boom, Pin Grabber Quick Coupler, and CB Linkage															
Bucket Type	Width of Bucket	SAE Capacity of Bucket	Weight of Bucket	With Blade						Without Blade					
				600 TG Shoe			850 TG Shoe			600 TG Shoe			850TG Shoe		
				Stick											
				2.65 m 8 ft 8 inch	3.2 m 10 ft 6 inch	3.75 m 12 ft 3 inch	2.65 m 8 ft 8 inch	3.2 m 10 ft 6 inch	3.75 m 12 ft 3 inch	2.65 m 8 ft 8 inch	3.2 m 10 ft 6 inch	3.75 m 12 ft 3 inch	2.65 m 8 ft 8 inch	3.2 m 10 ft 6 inch	3.75 m 12 ft 3 inch
General Duty (GD) 100% Fill	600 mm (24 inch)	0.52 m ³ (0.68 yd ³)	659 kg (1451 lb)	(1)	(1)	(1)	(1)	(1)	(1)	(1)	(1)	(1)	(1)	(1)	(1)
	750 mm (30 inch)	0.71 m ³ (0.93 yd ³)	726 kg (1599 lb)	(1)	(1)	(1)	(1)	(1)	(1)	(1)	(1)	(1)	(1)	(1)	(1)
	1000 mm (40 inch)	1.03 m ³ (1.35 yd ³)	834 kg (1838 lb)	(1)	(1)	(1)	(1)	(1)	(1)	(1)	(1)	(1)	(1)	(1)	(1)
	1350 mm (54 inch)	1.54 m ³ (2.02 yd ³)	1004 kg (2212 lb)	(1)	(2)	(3)	(1)	(1)	(2)	(1)	(2)	(3)	(1)	(2)	(3)
	1500 mm (60 inch)	1.76 m ³ (2.30 yd ³)	1068 kg (2353 lb)	(2)	(2)	(3)	(1)	(2)	(3)	(2)	(3)	(4)	(2)	(3)	(4)

(continued)

Product Information Section
 Boom/Stick/Bucket Combinations

(Table 7, contd)

	1600 mm (63 inch)	1.86 m ³ (2.43 yd ³)	1098 kg (2419 lb)	(2)	(3)	(4)	(2)	(3)	(3)	(3)	(4)	(4)	(2)	(3)	(4)
--	----------------------	--	----------------------	-----	-----	-----	-----	-----	-----	-----	-----	-----	-----	-----	-----

- (1) 2100 kg/m³ (3500 lb/yd³) is the maximum density of material.
- (2) 1800 kg/m³ (3000 lb/yd³) is the maximum density of material.
- (3) 1500 kg/m³ (2500 lb/yd³) is the maximum density of material.
- (4) 1200 kg/m³ (2000 lb/yd³) is the maximum density of material.

Table 8

335F Excavator with 6.15 m (20 ft 2 inch) Reach Boom, Pin Grabber Quick Coupler, and CB Linkage															
Bucket Type	Width of Bucket	SAE Capacity of Bucket	Weight of Bucket	With Blade						Without Blade					
				600 TG Shoe			850 TG Shoe			600 TG Shoe			850TG Shoe		
				Stick											
				2.65 m 8 ft 8 inch	3.2 m 10 ft 6 inch	3.75 m 12 ft 3 inch	2.65 m 8 ft 8 inch	3.2 m 10 ft 6 inch	3.75 m 12 ft 3 inch	2.65 m 8 ft 8 inch	3.2 m 10 ft 6 inch	3.75 m 12 ft 3 inch	2.65 m 8 ft 8 inch	3.2 m 10 ft 6 inch	3.75 m 12 ft 3 inch
Heavy Duty (HD) 100% Fill	600 mm (24 inch)	0.52 m ³ (0.68 yd ³)	808 kg (1780 lb)	(1)	(1)	(1)	(1)	(1)	(1)	(1)	(1)	(1)	(1)	(1)	(1)
	750 mm (30 inch)	0.71 m ³ (0.93 yd ³)	947 kg (2086 lb)	(1)	(1)	(1)	(1)	(1)	(1)	(1)	(1)	(1)	(1)	(1)	(1)
	900 mm (36 inch)	0.91 m ³ (1.19 yd ³)	1040 kg (2292 lb)	(1)	(1)	(1)	(1)	(1)	(1)	(1)	(1)	(1)	(1)	(1)	(1)
	1050 mm (42 inch)	1.12 m ³ (1.46 yd ³)	1134 kg (2498 lb)	(1)	(1)	(1)	(1)	(1)	(1)	(1)	(1)	(1)	(1)	(1)	(1)
	1200 mm (48 inch)	1.33 m ³ (1.74 yd ³)	1206 kg (2657 lb)	(1)	(1)	(1)	(1)	(1)	(1)	(1)	(1)	(2)	(1)	(1)	(1)
	1350 mm (54 inch)	1.54 m ³ (2.02 yd ³)	1305 kg (2876 lb)	(1)	(1)	(2)	(1)	(1)	(2)	(1)	(2)	(3)	(1)	(1)	(3)
	1500 mm (60 inch)	1.76 m ³ (2.30 yd ³)	1406 kg (3098 lb)	(1)	(2)	(3)	(1)	(2)	(3)	(2)	(3)	(4)	(2)	(3)	(3)
	1650 mm (66 inch)	1.97 m ³ (2.58 yd ³)	1477 kg (3254 lb)	(2)	(3)	(4)	(2)	(3)	(4)	(3)	(4)	(4)	(2)	(3)	(4)
Severe Duty (SD) 90% Fill	1050 mm (42 inch)	1.12 m ³ (1.46 yd ³)	1241 kg (2734 lb)	(1)	(1)	(1)	(1)	(1)	(1)	(1)	(1)	(1)	(1)	(1)	(1)

- (1) 2100 kg/m³ (3500 lb/yd³) is the maximum density of material.
- (2) 1800 kg/m³ (3000 lb/yd³) is the maximum density of material.
- (3) 1500 kg/m³ (2500 lb/yd³) is the maximum density of material.
- (4) 1200 kg/m³ (2000 lb/yd³) is the maximum density of material.

EAME

Without Quick Coupler

Table 9

335F Excavator with 6.15 m (20 ft 2 inch) Reach Boom and CB Linkage															
Bucket Type	Width of Bucket	SAE Capacity of Bucket	Weight of Bucket	With Blade						Without Blade					
				600 TG Shoe			850 TG Shoe			600 TG Shoe			850TG Shoe		
				Stick											
				2.65 m 8 ft 8 inch	3.2 m 10 ft 6 inch	3.75 m 12 ft 3 inch	2.65 m 8 ft 8 inch	3.2 m 10 ft 6 inch	3.75 m 12 ft 3 inch	2.65 m 8 ft 8 inch	3.2 m 10 ft 6 inch	3.75 m 12 ft 3 inch	2.65 m 8 ft 8 inch	3.2 m 10 ft 6 inch	3.75 m 12 ft 3 inch
General Duty (HD) 100% Fill	750 mm (30 inch)	0.71 m ³ (0.93 yd ³)	730 kg (1609 lb)	(1)	(1)	(1)	(1)	(1)	(1)	(1)	(1)	(1)	(1)	(1)	(1)
	1050 mm (42 inch)	1.12 m ³ (1.46 yd ³)	864 kg (1903 lb)	(1)	(1)	(1)	(1)	(1)	(1)	(1)	(1)	(1)	(1)	(1)	(1)
	1200 mm (48 inch)	1.33 m ³ (1.74 yd ³)	927 kg (2044 lb)	(1)	(1)	(1)	(1)	(1)	(1)	(1)	(1)	(1)	(1)	(1)	(1)
	1350 mm (54 inch)	1.54 m ³ (2.02 yd ³)	1009 kg (2224 lb)	(1)	(1)	(1)	(1)	(1)	(1)	(1)	(1)	(2)	(1)	(1)	(2)
	1500 mm (60 inch)	1.76 m ³ (2.30 yd ³)	1074 kg (2366 lb)	(1)	(2)	(2)	(1)	(1)	(2)	(1)	(2)	(3)	(1)	(2)	(3)
Heavy Duty (SD) 100 % Fill	1350 mm (54 inch)	1.54 m ³ (2.02 yd ³)	1134 kg (2499 lb)	(1)	(1)	(2)	(1)	(1)	(1)	(1)	(2)	(3)	(1)	(1)	(2)
	1500 mm (60 inch)	1.76 m ³ (2.30 yd ³)	1299 kg (2708 lb)	(1)	(2)	(3)	(1)	(1)	(2)	(2)	(3)	(4)	(1)	(2)	(3)
Severe Duty (SD) 90% Fill	1350 mm (54 inch)	1.56 m ³ (2.04 yd ³)	1245 kg (2744 lb)	(1)	(1)	(1)	(1)	(1)	(1)	(1)	(1)	(2)	(1)	(1)	(2)

(1) 2100 kg/m³ (3500 lb/yd³) is the maximum density of material.
 (2) 1800 kg/m³ (3000 lb/yd³) is the maximum density of material.
 (3) 1500 kg/m³ (2500 lb/yd³) is the maximum density of material.
 (4) 1200 kg/m³ (2000 lb/yd³) is the maximum density of material.

Product Information Section
Boom/Stick/Bucket Combinations

With Quick Coupler

Table 10

335F Excavator with 6.15 m (20 ft 2 inch) Reach Boom, Quick Coupler, and CB Linkage															
Bucket Type	Width of Bucket	SAE Capacity of Bucket	Weight of Bucket	With Blade						Without Blade					
				600 TG Shoe			850 TG Shoe			600 TG Shoe			850TG Shoe		
				Stick											
				2.65 m 8 ft 8 inch	3.2 m 10 ft 6 inch	3.75 m 12 ft 3 inch	2.65 m 8 ft 8 inch	3.2 m 10 ft 6 inch	3.75 m 12 ft 3 inch	2.65 m 8 ft 8 inch	3.2 m 10 ft 6 inch	3.75 m 12 ft 3 inch	2.65 m 8 ft 8 inch	3.2 m 10 ft 6 inch	3.75 m 12 ft 3 inch
General Duty (HD) 100% Fill	750 mm (30 inch)	0.70 m ³ (0.90 yd ³)	693 kg (1526 lb)	(1)	(1)	(1)	(1)	(1)	(1)	(1)	(1)	(1)	(1)	(1)	(1)
	1350 mm (54 inch)	1.5 m ³ (2.0 yd ³)	1008 kg (2221 lb)	(1)	(1)	(2)	(1)	(1)	(3)	(1)	(3)	(2)	(1)	(3)	(2)
	1500 mm (60 inch)	1.76 m ³ (2.30 yd ³)	1074 kg (2366 lb)	(1)	(3)	(2)	(1)	(3)	(2)	(3)	(2)	(4)	(3)	(2)	(4)
	1650 mm (66 inch)	1.97 m ³ (2.58 yd ³)	1157 kg (2550 lb)	(3)	(2)	(4)	(3)	(2)	(4)	(2)	(4)	(5)	(2)	(4)	(4)
Heavy Duty (SD) 100% Fill	1200 mm (48 inch)	1.33 m ³ (1.74 yd ³)	1061 kg (2338 lb)	(1)	(1)	(3)	(1)	(1)	(1)	(1)	(1)	(2)	(1)	(1)	(3)
	1350 mm (54 inch)	1.54 m ³ (2.02 yd ³)	1134 kg (2499 lb)	(1)	(3)	(2)	(1)	(1)	(3)	(3)	(2)	(4)	(1)	(3)	(2)
	1500 mm (60 inch)	1.76 m ³ (2.30 yd ³)	1299 kg (2709 lb)	(3)	(2)	(4)	(1)	(3)	(2)	(2)	(4)	(4)	(3)	(2)	(4)
	1650 mm (66 inch)	1.97 m ³ (2.58 yd ³)	1302 kg (2869 lb)	(2)	(2)	(4)	(3)	(2)	(4)	(2)	(4)	(5)	(2)	(4)	(5)

- (1) 2100 kg/m³ (3500 lb/yd³) is the maximum density of material.
(2) 1500 kg/m³ (2500 lb/yd³) is the maximum density of material.
(3) 1800 kg/m³ (3000 lb/yd³) is the maximum density of material.
(4) 1200 kg/m³ (2000 lb/yd³) is the maximum density of material.
(5) 900 kg/m³ (1500 lb/yd³) is the maximum density of material.

NACD

Without Quick Coupler

Table 11

335F Excavator with 6.15 m (20 ft 2 inch) Reach Boom and CB Linkage															
Bucket Type	Width of Bucket	SAE Capacity of Bucket	Weight of Bucket	With Blade						Without Blade					
				600 TG Shoe			850 TG Shoe			600 TG Shoe			850TG Shoe		
				Stick											
				2.65 m 8 ft 8 inch	3.2 m 10 ft 6 inch	3.75 m 12 ft 3 inch	2.65 m 8 ft 8 inch	3.2 m 10 ft 6 inch	3.75 m 12 ft 3 inch	2.65 m 8 ft 8 inch	3.2 m 10 ft 6 inch	3.75 m 12 ft 3 inch	2.65 m 8 ft 8 inch	3.2 m 10 ft 6 inch	3.75 m 12 ft 3 inch
General Duty (GDC) 100% Fill	600 mm (24 inch)	0.63 m ³ (0.83 yd ³)	724 kg (1595 lb)	(1)	(1)	(1)	(1)	(1)	(1)	(1)	(1)	(1)	(1)	(1)	(1)
	750 mm (30 inch)	0.86 m ³ (1.13 yd ³)	810 kg (1785 lb)	(1)	(1)	(1)	(1)	(1)	(1)	(1)	(1)	(1)	(1)	(1)	(1)
	900 mm (36 inch)	1.09 m ³ (1.43 yd ³)	907 kg (1998 lb)	(1)	(1)	(1)	(1)	(1)	(1)	(1)	(1)	(1)	(1)	(1)	(1)
	1050 mm (42 inch)	1.34 m ³ (1.75 yd ³)	979 kg (2157 lb)	(1)	(1)	(1)	(1)	(1)	(1)	(1)	(1)	(1)	(1)	(1)	(1)
	1200 mm (48 inch)	1.58 m ³ (2.07 yd ³)	1070 kg (2358 lb)	(1)	(1)	(2)	(1)	(1)	(1)	(1)	(2)	(3)	(1)	(1)	(2)
	1350 mm (54 inch)	1.83 m ³ (2.40 yd ³)	1164 kg (2564 lb)	(1)	(2)	(3)	(1)	(2)	(3)	(2)	(3)	(4)	(1)	(2)	(3)

- (1) 2100 kg/m³ (3500 lb/yd³) is the maximum density of material.
- (2) 1200 kg/m³ (2000 lb/yd³) is the maximum density of material.
- (3) 1500 kg/m³ (2500 lb/yd³) is the maximum density of material.
- (4) 1200 kg/m³ (2000 lb/yd³) is the maximum density of material.

Table 12

335F Excavator with 6.15 m (20 ft 2 inch) Reach Boom and CB Linkage															
Bucket Type	Width of Bucket	SAE Capacity of Bucket	Weight of Bucket	With Blade						Without Blade					
				600 TG Shoe			850 TG Shoe			600 TG Shoe			850TG Shoe		
				Stick											
				2.65 m 8 ft 8 inch	3.2 m 10 ft 6 inch	3.75 m 12 ft 3 inch	2.65 m 8 ft 8 inch	3.2 m 10 ft 6 inch	3.75 m 12 ft 3 inch	2.65 m 8 ft 8 inch	3.2 m 10 ft 6 inch	3.75 m 12 ft 3 inch	2.65 m 8 ft 8 inch	3.2 m 10 ft 6 inch	3.75 m 12 ft 3 inch
Heavy Duty (HD) 100% Fill	600 mm (24 inch)	0.52 m ³ (0.68 yd ³)	763 kg (1681 lb)	(1)	(1)	(1)	(1)	(1)	(1)	(1)	(1)	(1)	(1)	(1)	(1)
	750 mm (30 inch)	0.71 m ³ (0.93 yd ³)	847 kg (1866 lb)	(1)	(1)	(1)	(1)	(1)	(1)	(1)	(1)	(1)	(1)	(1)	(1)
	900 mm (36 inch)	0.91 m ³ (1.19 yd ³)	935 kg (2061 lb)	(1)	(1)	(1)	(1)	(1)	(1)	(1)	(1)	(1)	(1)	(1)	(1)
	1050 mm (42 inch)	1.12 m ³ (1.46 yd ³)	1024 kg (2256 lb)	(1)	(1)	(1)	(1)	(1)	(1)	(1)	(1)	(1)	(1)	(1)	(1)

(continued)

Product Information Section
Boom/Stick/Bucket Combinations

(Table 12, contd)

	1200 mm (48 inch)	1.33 m ³ (1.74 yd ³)	1095 kg (2413 lb)	(1)	(1)	(1)	(1)	(1)	(1)	(1)	(1)	(2)	(1)	(1)	(1)
	1350 mm (54 inch)	1.54 m ³ (2.02 yd ³)	1188 kg (2618 lb)	(1)	(1)	(2)	(1)	(1)	(1)	(1)	(2)	(3)	(1)	(1)	(1)
	1500 mm (60 inch)	1.76 m ³ (2.30 yd ³)	1285 kg (2831 lb)	(1)	(2)	(3)	(1)	(2)	(3)	(2)	(3)	(4)	(1)	(2)	(3)
	1650 mm (66 inch)	1.97 m ³ (2.58 yd ³)	1357 kg (2990 lb)	(2)	(3)	(4)	(1)	(2)	(3)	(3)	(3)	(4)	(2)	(3)	(4)

(1) 2100 kg/m³ (3500 lb/yd³) is the maximum density of material.

(2) 1800 kg/m³ (3000 lb/yd³) is the maximum density of material.

(3) 1500 kg/m³ (2500 lb/yd³) is the maximum density of material.

(4) 1200 kg/m³ (2000 lb/yd³) is the maximum density of material.

Table 13

335F Excavator with 6.15 m (20 ft 2 inch) Reach Boom and CB Linkage															
Bucket Type	Width of Bucket	SAE Capacity of Bucket	Weight of Bucket	With Blade						Without Blade					
				600 TG Shoe			850 TG Shoe			600 TG Shoe			850TG Shoe		
				Stick											
				2.65 m 8 ft 8 inch	3.2 m 10 ft 6 inch	3.75 m 12 ft 3 inch	2.65 m 8 ft 8 inch	3.2 m 10 ft 6 inch	3.75 m 12 ft 3 inch	2.65 m 8 ft 8 inch	3.2 m 10 ft 6 inch	3.75 m 12 ft 3 inch	2.65 m 8 ft 8 inch	3.2 m 10 ft 6 inch	3.75 m 12 ft 3 inch
Severe Duty (SD) 90% Fill	600 mm (24 inch)	0.52 m ³ (0.68 yd ³)	810 kg (1784 lb)	(1)	(1)	(1)	(1)	(1)	(1)	(1)	(1)	(1)	(1)	(1)	(1)
	750 mm (30 inch)	0.71 m ³ (0.93 yd ³)	902 kg (1987 lb)	(1)	(1)	(1)	(1)	(1)	(1)	(1)	(1)	(1)	(1)	(1)	(1)
	900 mm (36 inch)	0.91 m ³ (1.19 yd ³)	999 kg (2202 lb)	(1)	(1)	(1)	(1)	(1)	(1)	(1)	(1)	(1)	(1)	(1)	(1)
	1050 mm (42 inch)	1.12 m ³ (1.46 yd ³)	1097 kg (2417 lb)	(1)	(1)	(1)	(1)	(1)	(1)	(1)	(1)	(1)	(1)	(1)	(1)
	1200 mm (48 inch)	1.33 m ³ (1.74 yd ³)	1178 kg (2595 lb)	(1)	(1)	(1)	(1)	(1)	(1)	(1)	(1)	(1)	(1)	(1)	(1)

(1) 2100 kg/m³ (3500 lb/yd³) is the maximum density of material.

With Quick Coupler

Table 14

335F Excavator with 6.15 m (20 ft 2 inch) Reach Boom, Pin Grabber Quick Coupler, and CB Linkage															
Bucket Type	Width of Bucket	SAE Capacity of Bucket	Weight of Bucket	With Blade						Without Blade					
				600 TG Shoe			850 TG Shoe			600 TG Shoe			850TG Shoe		
				Stick											
				2.65 m 8 ft 8 inch	3.2 m 10 ft 6 inch	3.75 m 12 ft 3 inch	2.65 m 8 ft 8 inch	3.2 m 10 ft 6 inch	3.75 m 12 ft 3 inch	2.65 m 8 ft 8 inch	3.2 m 10 ft 6 inch	3.75 m 12 ft 3 inch	2.65 m 8 ft 8 inch	3.2 m 10 ft 6 inch	3.75 m 12 ft 3 inch
General Duty (GDC) 100% Fill	600 mm (24 inch)	0.63 m ³ (0.83 yd ³)	724 kg (1595 lb)	(1)	(1)	(1)	(1)	(1)	(1)	(1)	(1)	(1)	(1)	(1)	(1)
	750 mm (30 inch)	0.86 m ³ (1.13 yd ³)	810 kg (1785 lb)	(1)	(1)	(1)	(1)	(1)	(1)	(1)	(1)	(1)	(1)	(1)	(1)
	900 mm (36 inch)	1.09 m ³ (1.43 yd ³)	907 kg (1998 lb)	(1)	(1)	(1)	(1)	(1)	(1)	(1)	(1)	(1)	(1)	(1)	(1)
	1050 mm (42 inch)	1.34 m ³ (1.75 yd ³)	979 kg (2157 lb)	(1)	(1)	(2)	(1)	(1)	(1)	(1)	(1)	(3)	(1)	(1)	(2)
	1200 mm (48 inch)	1.58 m ³ (2.07 yd ³)	1070 kg (2358 lb)	(1)	(2)	(3)	(1)	(1)	(2)	(2)	(3)	(4)	(1)	(2)	(3)
	1350 mm (54 inch)	1.83 m ³ (2.40 yd ³)	1164 kg (2564 lb)	(2)	(3)	(4)	(2)	(3)	(3)	(3)	(4)	(5)	(2)	(3)	(4)

- (1) 2100 kg/m³ (3500 lb/yd³) is the maximum density of material.
- (2) 1800 kg/m³ (3000 lb/yd³) is the maximum density of material.
- (3) 1500 kg/m³ (2500 lb/yd³) is the maximum density of material.
- (4) 1200 kg/m³ (2000 lb/yd³) is the maximum density of material.
- (5) 900 kg/m³ (1500 lb/yd³) is the maximum density of material.

Table 15

335F Excavator with 6.15 m (20 ft 2 inch) Reach Boom, Pin Grabber Quick Coupler, and CB Linkage															
Bucket Type	Width of Bucket	SAE Capacity of Bucket	Weight of Bucket	With Blade						Without Blade					
				600 TG Shoe			850 TG Shoe			600 TG Shoe			850TG Shoe		
				Stick											
				2.65 m 8 ft 8 inch	3.2 m 10 ft 6 inch	3.75 m 12 ft 3 inch	2.65 m 8 ft 8 inch	3.2 m 10 ft 6 inch	3.75 m 12 ft 3 inch	2.65 m 8 ft 8 inch	3.2 m 10 ft 6 inch	3.75 m 12 ft 3 inch	2.65 m 8 ft 8 inch	3.2 m 10 ft 6 inch	3.75 m 12 ft 3 inch
Heavy Duty (HD) 100% Fill	600 mm (24 inch)	0.52 m ³ (0.68 yd ³)	763 kg (1681 lb)	(1)	(1)	(1)	(1)	(1)	(1)	(1)	(1)	(1)	(1)	(1)	(1)
	750 mm (30 inch)	0.71 m ³ (0.93 yd ³)	847 kg (1866 lb)	(1)	(1)	(1)	(1)	(1)	(1)	(1)	(1)	(1)	(1)	(1)	(1)
	900 mm (36 inch)	0.91 m ³ (1.19 yd ³)	935 kg (2061 lb)	(1)	(1)	(1)	(1)	(1)	(1)	(1)	(1)	(1)	(1)	(1)	(1)
	1050 mm (42 inch)	1.12 m ³ (1.46 yd ³)	1024 kg (2256 lb)	(1)	(1)	(1)	(1)	(1)	(1)	(1)	(1)	(2)	(1)	(1)	(1)

(continued)

Product Information Section
Lifting Capacities

(Table 15, contd)

	1200 mm (48 inch)	1.33 m ³ (1.74 yd ³)	1095 kg (2413 lb)	(1)	(1)	(2)	(1)	(1)	(1)	(1)	(2)	(3)	(1)	(1)	(2)
	1350 mm (54 inch)	1.54 m ³ (2.02 yd ³)	1188 kg (2618 lb)	(1)	(2)	(3)	(1)	(1)	(3)	(2)	(3)	(4)	(1)	(2)	(3)
	1500 mm (60 inch)	1.76 m ³ (2.30 yd ³)	1285 kg (2831 lb)	(2)	(3)	(5)	(2)	(3)	(4)	(3)	(4)	(5)	(2)	(3)	(4)
	1650 mm (66 inch)	1.97 m ³ (2.58 yd ³)	1357 kg (2990 lb)	(3)	(4)	(5)	(2)	(3)	(4)	(4)	(4)	(5)	(3)	(4)	(5)

- (1) 2100 kg/m³ (3500 lb/yd³) is the maximum density of material.
 (2) 1800 kg/m³ (3000 lb/yd³) is the maximum density of material.
 (3) 1500 kg/m³ (2500 lb/yd³) is the maximum density of material.
 (4) 1200 kg/m³ (2000 lb/yd³) is the maximum density of material.
 (5) 900 kg/m³ (1500 lb/yd³) is the maximum density of material.

Table 16

335F Excavator with 6.15 m (20 ft 2 inch) Reach Boom, Pin Grabber Quick Coupler, and CB Linkage															
Bucket Type	Width of Bucket	SAE Capacity of Bucket	Weight of Bucket	With Blade						Without Blade					
				600 TG Shoe			850 TG Shoe			600 TG Shoe			850TG Shoe		
				Stick											
				2.65 m 8 ft 8 inch	3.2 m 10 ft 6 inch	3.75 m 12 ft 3 inch	2.65 m 8 ft 8 inch	3.2 m 10 ft 6 inch	3.75 m 12 ft 3 inch	2.65 m 8 ft 8 inch	3.2 m 10 ft 6 inch	3.75 m 12 ft 3 inch	2.65 m 8 ft 8 inch	3.2 m 10 ft 6 inch	3.75 m 12 ft 3 inch
Severe Duty (SD) 90% Fill	600 mm (24 inch)	0.52 m ³ (0.68 yd ³)	810 kg (1784 lb)	(1)	(1)	(1)	(1)	(1)	(1)	(1)	(1)	(1)	(1)	(1)	(1)
	750 mm (30 inch)	0.71 m ³ (0.93 yd ³)	902 kg (1987 lb)	(1)	(1)	(1)	(1)	(1)	(1)	(1)	(1)	(1)	(1)	(1)	(1)
	900 mm (36 inch)	0.91 m ³ (1.19 yd ³)	999 kg (2202 lb)	(1)	(1)	(1)	(1)	(1)	(1)	(1)	(1)	(1)	(1)	(1)	(1)
	1050 mm (42 inch)	1.12 m ³ (1.46 yd ³)	1097 kg (2417 lb)	(1)	(1)	(1)	(1)	(1)	(1)	(1)	(1)	(1)	(1)	(1)	(1)
	1200 mm (48 inch)	1.33 m ³ (1.74 yd ³)	1178 kg (2595 lb)	(1)	(1)	(1)	(1)	(1)	(1)	(1)	(1)	(2)	(1)	(1)	(3)

- (1) 2100 kg/m³ (3500 lb/yd³) is the maximum density of material.
 (2) 1500 kg/m³ (2500 lb/yd³) is the maximum density of material.
 (3) 1800 kg/m³ (3000 lb/yd³) is the maximum density of material.

i05959206

Lifting Capacities

SMCS Code: 7000

WARNING

Failure to comply to the rated load can cause possible personal injury or property damage. Review the rated load of a particular work tool before performing any operation. Make adjustments to the rated load as necessary for non-standard configurations.

There may be local regulations and/or government regulations that govern the use of excavators which lift heavy objects. Obey all local and government regulations.

Lifting capacities should be used as a guide. Work tools, uneven ground conditions, soft ground conditions, or poor ground conditions have effects on lifting capacities. The operator is responsible for being aware of these effects.

The lifting capacities are defined by "ISO 10567 2007". The lifting capacities are defined as the lower value of 75% of the static tipping capacity or 87% of the hydraulic lift capacity.

Note: Lifting capacities are based upon a standard machine with the following conditions:

- Lift point: Stick nose without bucket
- Lubricants full
- Fuel tank full
- Steel track
- Complete cab with a 75 kg (165 lb) operator

Lifting capacities will vary with different work tools and attachments. The weight of a work tool attachment must be subtracted from the lift capacity. Consult your Cat dealer regarding the lifting capacities for specific work tools and attachments.

This machine may be equipped with various sticks. Lifting capacities may vary between the different sticks. Measure the distance on the stick between the boom hinge pin and the work tool hinge pin. This distance will inform you of the size of the stick that is equipped on the machine.

Use the lifting eye that is provided on the stick nose in order to lift objects. When the lifting eye is used, the connection must be made with a sling or shackle.

Note: Japan regulations require a shovel crane configuration in order to lift certain objects. A shovel crane has a rated load capacity, therefore, the lift capacities discussed below do not apply to a shovel crane configuration. Contact your Cat dealer for additional information.

Note: In European countries, regulations require a load sensing indicator and a boom and stick lowering control device if more than 1000 kg (2200 lb) is lifted during object handling applications. Regulations also require a load sensing indicator and a boom lowering control device if a force that is greater than 40000 N·m (29500 lb ft) is created during object handling applications. Even if the hydraulic lift capacity is capable, do not exceed a load of 1000 kg (2200 lb). Do not exceed a force of 40000 N·m (29500 lb ft) in European object handling applications.

Symbols Found in the Lifting Capacity Charts

Below are symbols that are commonly found on lifting capacity charts for track excavators.

Note: Depending on the machine configuration, some symbols may not be used.

(mm) **Measurements are provided in millimeters and inches**
(inch)



Lift Capacities are provided in kilograms and pounds



Load is limited by hydraulic lifting capacity rather than by a tipping load



Lift point radius



Lift point height



Lifting capacity over the front of the machine



Lifting capacity over the side of the machine



Heavy Lift ON











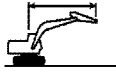
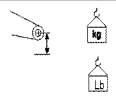





Blade UP

**335F LCR6150 mm (242 inch)
Reach Boom with a 3200 mm
(126 inch)Stick and 7700 kg
(16975 lb) Counterweight**

Product Information Section
Lifting Capacities

850 mm (33 inch)TG Track Shoes

(mm) (inch)	1500 60		3000 120		4500 180		6000 240		7500 300		9000 360				(mm) (inch)		
																	
9000 360							* 5800	* 5800							* 5650	* 5650	6040
															* 12650	* 12650	230
7500 300							* 7350	* 7350							* 5100	* 5100	7440
							* 16200	* 16200							* 11250	* 11250	290
6000 240							* 7800	* 7800	* 7300	6050					* 4900	* 4900	8330
							* 17000	* 17000	* 15900	13050					* 10750	* 10750	330
4500 180			* 15550	* 15550	* 10800	* 10800	* 8800	8300	* 7700	5950					* 4900	4550	8890
			* 33000	* 33000	* 23200	* 23200	* 19000	17900	* 16800	12750					* 10700	10000	350
3000 120					* 13350	12000	* 10000	7900	* 8300	5750	* 6150	4350			* 5050	4250	9160
					* 28750	25900	* 21600	17050	* 18000	12350	* 11200	9400			* 11050	9350	360
1500 60					* 15200	11350	* 11000	7550	* 8800	5550	* 6850	4300			* 5350	4150	9180
					* 32850	24450	* 23800	16300	* 19100	11950	* 12450	9200			* 11750	9150	370
0 0			* 5700	* 5700	* 15700	11050	* 11500	7350	* 9050	5400					* 5950	4250	8950
			* 13100	* 13100	* 33950	23750	* 24900	15800	* 19600	11650					* 13050	9400	360
-1500 -60	* 7100	* 7100	* 10800	* 10800	* 15050	10950	* 11300	7250	* 8800	5350					* 6900	4600	8440
	* 15850	* 15850	* 24450	* 24450	* 32650	23600	* 24450	15600	* 19000	11550					* 15250	10150	340
-3000 -120			* 17250	* 17250	* 13450	11050	* 10250	7300	* 7600	5450					* 7400	5350	7600
			* 39150	* 39150	* 29050	23800	* 22050	15700							* 16200	11850	300
-4500 -180			* 13550	* 13550	* 10450	* 10450	* 7550	7500							* 6900	* 6900	6300
			* 28950	* 28950	* 22200	* 22200	* 15700	* 15700							* 15050	* 15050	250











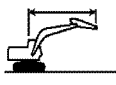















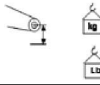



(mm) (inch)	1500 60		3000 120		4500 180		6000 240		7500 300		9000 360					
															(mm) (inch)	
+i																
9000 360							* 6350	* 6350							* 6200 * 6200 * 13800 * 13800	6040 230
7500 300							* 8100	* 8100							* 5550 * 5550 * 12300 * 12300	7440 290
6000 240							* 8600	* 8600	* 8050	6050					* 5350 5100 * 11750 11300	8330 330
4500 180			* 17050	* 17050	* 11850	* 11850	* 9650	8300	* 8500	5950					* 5350 4550 * 11750 10000	8890 350
3000 120					* 14700	12000	* 11000	7900	* 9150	5750	* 6750	4350			* 5500 4250 * 12100 9350	9160 360
1500 60					* 16750	11350	* 12150	7550	9350	5550	7150	4300			* 5850 4150 * 12900 9150	9180 370
0 0			* 6050	* 6050	* 17300	11050	* 12700	7350	9200	5400					* 6500 4250 * 14300 9400	8950 360
-1500 -60	* 7550	* 7550	* 11450	* 11450	* 16650	10950	* 12500	7250	9150	5350					* 7550 4600 * 16700 10150	8440 340
-3000 -120	* 16800	* 16800	* 25900	* 25900	* 36050	23600	* 27000	15600	19700	11550					* 8200 5350 * 18000 11850	7600 300
-4500 -180			* 18300	* 18300	* 14850	11050	* 11300	7300	* 8400	5450					* 7650 7050 * 16750 15800	6300 250

















Illustration 67

g03384840

Product Information Section
Lifting Capacities











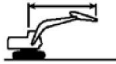



700 mm (28 inch)TG Track Shoes

(mm) (inch)	1500 60		3000 120		4500 180		6000 240		7500 300		9000 360				(mm) (inch)	
																
9000 360							* 5800	* 5800						* 5650	* 5650	6040
														* 12650	* 12650	230
7500 300							* 7350	* 7350						* 5100	* 5100	7440
							* 16200	* 16200						* 11250	* 11250	290
6000 240							* 7800	* 7800	* 7300	5900				* 4900	* 4900	8330
							* 17000	* 17000	* 15900	12650				* 10750	* 10750	330
4500 180			* 15550	* 15550	* 10800	* 10800	* 8800	8100	* 7700	5750				* 4900	4400	8890
			* 33000	* 33000	* 23200	* 23200	* 19000	17400	* 16800	12400				* 10700	9700	350
3000 120					* 13350	11700	* 10000	7700	* 8300	5550	* 6150	4250		* 5050	4100	9160
					* 28750	25200	* 21600	16550	* 18000	12000	* 11200	9100		* 11050	9100	360
1500 60					* 15200	11000	* 11000	7350	* 8800	5400	* 6850	4150		* 5350	4050	9180
					* 32850	23750	* 23800	15800	* 19100	11600	* 12450	8900		* 11750	8900	370
0 0			* 5700	* 5700	* 15700	10700	* 11500	7100	8950	5250				* 5950	4150	8950
			* 13100	* 13100	* 33950	23050	* 24900	15300	19250	11300				* 13050	9100	360
-1500 -60	* 7100	* 7100	* 10800	* 10800	* 15050	10650	* 11300	7000	* 8800	5200				* 6900	4450	8440
	* 15850	* 15850	* 24450	* 24450	* 32650	22850	* 24450	15100	* 19000	11200				* 15250	9850	340
-3000 -120			* 17250	* 17250	* 13450	10750	* 10250	7050	* 7600	5250				* 7400	5200	7600
			* 39150	* 39150	* 29050	23050	* 22050	15200						* 16200	11450	300
-4500 -180			* 13550	* 13550	* 10450	* 10450	* 7550	7300						* 6900	6850	6300
			* 28950	* 28950	* 22200	* 22200	* 15700	* 15700						* 15050	* 15050	250

(mm) (inch)	1500 60		3000 120		4500 180		6000 240		7500 300		9000 360				(mm) (inch)		
 +2																	
9000 360							* 6350	* 6350					* 6200	* 6200	6040		
7500 300							* 8100	* 8100					* 5550	* 5550	7440		
6000 240							* 17800	* 17800					* 12300	* 12300	290		
4500 180			* 17050	* 17050	* 11850	* 11850	* 8600	8400	* 8050	5900			* 5350	4950	8330		
3000 120			* 36150	* 36150	* 25500	* 25500	* 18700	18050	* 17350	12650			* 11750	11000	330		
1500 60					* 14700	11700	* 9650	8100	* 8500	5750			* 5350	4400	8890		
0					* 36150	* 36150	* 20950	17400	* 18550	12400			* 11750	9700	350		
-1500 -60	* 7550	* 7550	* 11450	* 11450	* 16650	10650	12400	7000	8900	5200			* 6750	4250	* 5500	4100	9160
-3000 -120	* 16800	* 16800	* 25900	* 25900	* 36050	22850	26600	15100	19100	11200			* 12250	9100	* 12100	9100	360
-4500 -180			* 18300	* 18300	* 14850	10750	* 11300	7050	* 8400	5250			* 5850	4050	* 5850	4050	9180
			* 41500	* 41500	* 32150	23050	* 24400	15200					* 13600	8900	* 12900	8900	370
			* 6050	* 6050	* 17300	10700	12500	7100	8950	5250			* 6500	4150	* 6500	4150	8950
			* 13900	* 13900	* 37500	23050	26850	15300	19250	11300			* 14300	9100	* 14300	9100	360
			* 18300	* 18300	* 14850	10750	* 11300	7050	* 8400	5250			* 8200	5200	* 8200	5200	7600
			* 41500	* 41500	* 32150	23050	* 24400	15200					* 18000	11450	* 18000	11450	300
			* 15050	* 15050	* 11550	11000	* 8400	7300					* 7650	6850	* 7650	6850	6300
			* 32200	* 32200	* 24650	23650	* 17450	15750					* 16750	15350	* 16750	15350	250

Product Information Section
Lifting Capacities

600 mm (24 inch)TG Track Shoes

(mm) (inch)	1500 60		3000 120		4500 180		6000 240		7500 300		9000 360				(mm) (inch)	
																
9000 360							* 5800	* 5800						* 5650	* 5650	6040
														* 12650	* 12650	230
7500 300							* 7350	* 7350						* 5100	* 5100	7440
							* 16200	* 16200						* 11250	* 11250	290
6000 240							* 7800	* 7800	* 7300	5850				* 4900	* 4900	8330
							* 17000	* 17000	* 15900	12550				* 10750	* 10750	330
4500 180			* 15550	* 15550	* 10800	* 10800	* 8800	8000	* 7700	5700				* 4900	4350	8890
			* 33000	* 33000	* 23200	* 23200	* 19000	17250	* 16800	12250				* 10700	9600	350
3000 120					* 13350	11600	* 10000	7600	* 8300	5500	* 6150	4200		* 5050	4100	9160
					* 28750	24950	* 21600	16400	* 18000	11850	* 11200	9000		* 11050	9000	360
1500 60					* 15200	10900	* 11000	7250	* 8800	5350	* 6850	4100		* 5350	4000	9180
					* 32850	23500	* 23800	15650	* 19100	11450	* 12450	8850		* 11750	8800	370
0 0			* 5700	* 5700	* 15700	10600	* 11500	7050	8850	5200				* 5950	4100	8950
			* 13100	* 13100	* 33950	22800	* 24900	15150	19050	11150				* 13050	9000	360
-1500 -60	* 7100	* 7100	* 10800	* 10800	* 15050	10550	* 11300	6950	8800	5150				* 6900	4400	8440
	* 15850	* 15850	* 24450	* 24450	* 32650	22650	* 24450	14950	18900	11050				* 15250	9750	340
-3000 -120			* 17250	* 17250	* 13450	10600	* 10250	7000	* 7600	5200				* 7400	5150	7600
			* 39150	* 39150	* 29050	22850	* 22050	15050						* 16200	11350	300
-4500 -180			* 13550	* 13550	* 10450	* 10450	* 7550	7200						* 6900	6750	6300
			* 28950	* 28950	* 22200	* 22200	* 15700	15550						* 15050	* 15050	250











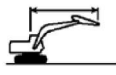















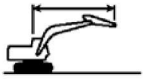

(mm) (inch)	1500 60		3000 120		4500 180		6000 240		7500 300		9000 360					
 															(mm) (inch)	
+Z																
9000 360								* 6350	* 6350					* 6200	* 6200	6040
														* 13800	* 13800	230
7500 300								* 8100	* 8100					* 5550	* 5550	7440
								* 17800	* 17800					* 12300	* 12300	290
6000 240								* 8600	8300	* 8050	5850			* 5350	4900	8330
								* 18700	17900	* 17350	12550			* 11750	10900	330
4500 180			* 17050	* 17050	* 11850	* 11850	* 9650	8000	* 8500	5700				* 5350	4350	8890
			* 36150	* 36150	* 25500	* 25500	* 20950	17250	* 18550	12250				* 11750	9600	350
3000 120					* 14700	11600	* 11000	7600	* 9150	5500	* 6750	4200		* 5500	4100	9160
					* 31700	24950	* 23800	16400	19800	11850	* 12250	9000		* 12100	9000	360
1500 60					* 16750	10900	* 12150	7250	9000	5350	6900	4100		* 5850	4000	9180
					* 36200	23500	* 26250	15650	19350	11450	* 13600	8850		* 12900	8800	370
0 0			* 6050	* 6050	* 17300	10600	12350	7050	8850	5200				* 6500	4100	8950
			* 13900	* 13900	* 37500	22800	26600	15150	19050	11150				* 14300	9000	360
-1500 -60	* 7550	* 7550	* 11450	* 11450	* 16650	10550	12250	6950	8800	5150				7450	4400	8440
	* 16800	* 16800	* 25900	* 25900	* 36050	22650	26350	14950	18900	11050				16450	9750	340
-3000 -120			* 18300	* 18300	* 14850	10600	* 11300	7000	* 8400	5200				* 8200	5150	7600
			* 41500	* 41500	* 32150	22850	* 24400	15050						* 18000	11350	300
-4500 -180			* 15050	* 15050	* 11550	10900	* 8400	7200						* 7650	6750	6300
			* 32200	* 32200	* 24650	23450	* 17450	15550						* 16750	15200	250

Illustration 71

g03739074

**335F LCR 6150 mm (242 inch)
Reach Boom with a 2650 mm
(104 inch)Stick and 7700 kg
(16975 lb) Counterweight**

850 mm (33 inch)TG Track Shoes

(mm) (inch)	3000 120		4500 180		6000 240		7500 300				(mm) (inch)	
 												
9000 360										* 7600 * 17100	* 7600 * 17100	5290 200
7500 300					* 8200 * 18000	* 8200 * 18000				* 6650 * 14750	* 6650 * 14750	6850 270
6000 240					* 8500 * 18550	* 8500 18400	* 7950 * 16200	6050 12950	* 6300 * 13900	5650 12550		7810 310
4500 180			* 11900 * 25600	* 11900 * 25600	* 9450 * 20450	8250 17750	* 8200 * 17900	5950 12750	* 6250 * 13800	5000 11000		8400 330
3000 120			* 14400 * 30950	11900 25600	* 10550 * 22850	7900 17000	* 8700 * 18900	5750 12400	* 6450 * 14200	4650 10250		8690 350
1500 60			* 15200 * 34100	11350 24450	* 11400 * 24700	7600 16400	* 9100 * 19750	5600 12050	* 6900 * 15100	4550 10050		8710 350
0 0			* 15700 * 34100	11150 24000	* 11700 * 25300	7450 16000	* 9200 * 19850	5500 11850	* 7650 * 16800	4700 10350		8460 340
-1500 -60	* 10850 * 24750	* 10850 * 24750	* 14700 * 31850	11150 24000	* 11200 * 24200	7400 15900	* 8600 * 18500	5500 11850	* 7900 * 17350	5150 11300		7920 320
-3000 -120	* 16100 * 34950	* 16100 * 34950	* 12650 * 27300	11300 24300	* 9700 * 20750	7450 16100			* 7600 * 16750	6100 13500		7020 280
-4500 -180			* 8850 * 18600	* 8850 * 18600					* 6600 * 14300	* 6600 * 14300		5580 220











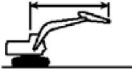











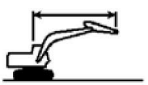



(mm) (inch)	3000 120		4500 180		6000 240		7500 300				(mm) (inch)
											
+i											
9000 360									* 8300 * 18600	* 8300 * 18600	5290 200
7500 300					* 9000 * 19750	8700 18600			* 7250 * 16100	7000 15750	6850 270
6000 240					* 9350 * 20400	8550 18400	* 8750 * 17650	6050 12950	* 6900 * 15200	5650 12550	7810 310
4500 180			* 13100 * 28150	12700 27350	* 10400 * 22500	8250 17750	* 9050 * 19700	5950 12750	* 6850 * 15050	5000 11000	8400 330
3000 120			* 15850 * 34050	11900 25600	* 11650 * 25150	7900 17000	9600 20600	5750 12400	* 7050 * 15500	4650 10250	8690 350
1500 60			* 16050 * 37550	11350 24450	* 12600 * 27250	7600 16400	9400 20250	5600 12050	* 7500 * 16500	4550 10050	8710 350
0 0			* 17300 * 37550	11150 24000	* 12900 * 27850	7450 16000	9300 20000	5500 11850	7850 17300	4700 10350	8460 340
-1500 -60	* 11500 * 26200	* 11500 * 26200	* 16200 * 35150	11150 24000	* 12350 * 26700	7400 15900	9300 20000	5500 11850	8600 19000	5150 11300	7920 320
-3000 -120	* 17800 * 38650	* 17800 * 38650	* 13950 * 30200	11300 24300	* 10700 * 22950	7450 16100			* 8450 * 18550	6100 13500	7020 280
-4500 -180			* 9850 * 20700	* 9850 * 20700					* 7350 * 15950	* 7350 * 15950	5580 220

Illustration 73

g03739162

700 mm (28 inch)TG Track Shoes

(mm) (inch)	3000 120		4500 180		6000 240		7500 300					
  											(mm) (inch)	
9000 360		+								* 7600 * 17100	* 7600 * 17100	5290 200
7500 300					* 8200 * 18000	* 8200 * 18000				* 6650 * 14750	* 6650 * 14750	6850 270
6000 240					* 8500 * 18550	8300 17900	* 7950 * 16200	5850 12550	* 6300 * 13900	5500 12200		7810 310
4500 180			* 11900 * 25600	* 11900 * 25600	* 9450 * 20450	8050 17300	* 8200 * 17900	5750 12400	* 6250 * 13800	4850 10650		8400 330
3000 120			* 14400 * 30950	11550 24900	* 10550 * 22850	7700 16550	* 8700 * 18900	5600 12050	* 6450 * 14200	4500 9950		8690 350
1500 60			* 15200 * 34100	11000 23750	* 11400 * 24700	7400 15900	* 9100 19650	5450 11700	* 6900 * 15100	4450 9750		8710 350
0 0			* 15700 * 34100	10850 23300	* 11700 * 25300	7200 15550	9050 19450	5350 11500	7650 16800	4550 10000		8460 340
-1500 -60	* 10850 * 24750	* 10850 * 24750	* 14700 * 31850	10850 23300	* 11200 * 24200	7150 15450	* 8600 * 18500	5350 11500	* 7900 * 17350	5000 10950		7920 320
-3000 -120	* 16100 * 34950	* 16100 * 34950	* 12650 * 27300	11000 23600	* 9700 * 20750	7250 15600			* 7600 * 16750	5900 13100		7020 280
-4500 -180			* 8850 * 18600	* 8850 * 18600					* 6600 * 14300	* 6600 * 14300		5580 220











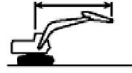



(mm) (inch)	3000 120		4500 180		6000 240		7500 300				(mm) (inch)
  											
+2											
9000 360									* 8300 * 18600	* 8300 * 18600	5290 200
7500 300					* 9000 * 19750	8450 18150			* 7250 * 16100	6800 15350	6850 270
6000 240					* 9350 * 20400	8300 17900	* 8750 * 17650	5850 12550	* 6900 * 15200	5500 12200	7810 310
4500 180			* 13100 * 28150	12350 26650	* 10400 * 22500	8050 17300	* 9050 * 19700	5750 12400	* 6850 * 15050	4850 10650	8400 330
3000 120			* 15850 * 34050	11550 24900	* 11650 * 25150	7700 16550	9300 20050	5600 12050	* 7050 * 15500	4500 9950	8690 350
1500 60			* 16050 * 37550	11000 23750	* 12600 * 27250	7400 15900	9150 19650	5450 11700	7350 16200	4450 9750	8710 350
0 0			* 17300 * 37550	10850 23300	12600 27050	7200 15550	9050 19450	5350 11500	7650 16800	4550 10000	8460 340
-1500 -60	* 11500 * 26200	* 11500 * 26200	* 16200 * 35150	10850 23300	* 12350 * 26700	7150 15450	9000 19400	5350 11500	8350 18450	5000 10950	7920 320
-3000 -120	* 17800 * 38650	* 17800 * 38650	* 13950 * 30200	11000 23600	* 10700 * 22950	7250 15600			* 8450 * 18550	5900 13100	7020 280
-4500 -180			* 9850 * 20700	* 9850 * 20700					* 7350 * 15950	* 7350 * 15950	5580 220

Illustration 75

g03739166

600 mm (24 inch) TG Track Shoes











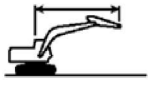



(mm) (inch)	3000 120		4500 180		6000 240		7500 300				(mm) (inch)
  											
9000 360									* 7600 * 17100	* 7600 * 17100	5290 200
7500 300					* 8200 * 18000	* 8200 18000			* 6650 * 14750	* 6650 * 14750	6850 270
6000 240					* 8500 * 18550	8250 17750	* 7950 * 16200	5800 12450	* 6300 * 13900	5450 12050	7810 310
4500 180			* 11900 * 25600	* 11900 * 25600	* 9450 * 20450	7950 17150	* 8200 * 17900	5700 12250	* 6250 * 13800	4800 10550	8400 330
3000 120			* 14400 * 30950	11450 24700	* 10550 * 22850	7600 16400	* 8700 * 18900	5550 11900	* 6450 * 14200	4450 9850	8690 350
1500 60			* 15200 * 34100	10900 23500	* 11400 * 24700	7300 15750	9050 19500	5400 11600	* 6900 * 15100	4400 9650	8710 350
0 0			* 15700 * 34100	10750 23050	* 11700 * 25300	7150 15350	8950 19250	5300 11400	7550 16600	4500 9900	8460 340
-1500 -60	* 10850 * 24750	* 10850 * 24750	* 14700 * 31850	10750 23050	* 11200 * 24200	7100 15250	* 8600 * 18500	5250 11350	* 7900 * 17350	4950 10850	7920 320
-3000 -120	* 16100 * 34950	* 16100 * 34950	* 12650 * 27300	10850 23350	* 9700 * 20750	7150 15450			* 7600 * 16750	5850 13000	7020 280
-4500 -180			* 8850 * 18600	* 8850 * 18600					* 6600 * 14300	* 6600 * 14300	5580 220

Illustration 76











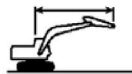
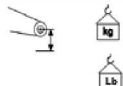









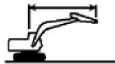







(mm) (inch)	3000 120		4500 180		6000 240		7500 300				
											(mm) (inch)
+2		+									
9000 360									* 8300 * 18600	* 8300 * 18600	5290 200
7500 300					* 9000 * 19750	8400 18000			* 7250 * 16100	6750 15200	6850 270
6000 240					* 9350 * 20400	8250 17750	* 8750 * 17650	5800 12450	* 6900 * 15200	5450 12050	7810 310
4500 180			* 13100 * 28150	12250 26450	* 10400 * 22500	7950 17150	* 9050 * 19700	5700 12250	* 6850 * 15050	4800 10550	8400 330
3000 120			* 15850 * 34050	11450 24700	* 11650 * 25150	7600 16400	9250 19850	5550 11900	* 7050 * 15500	4450 9850	8690 350
1500 60			* 16050 * 37550	10900 23500	* 12600 * 27200	7300 15750	9050 19500	5400 11600	7300 16050	4400 9650	8710 350
0 0			* 17300 * 37550	10750 23050	12450 26800	7150 15350	8950 19250	5300 11400	7550 16600	4500 9900	8460 340
-1500 -60	* 11500 * 26200	* 11500 * 26200	* 16200 * 35150	10750 23050	* 12350 * 26650	7100 15250	8950 19200	5250 11350	8300 18300	4950 10850	7920 320
-3000 -120	* 17800 * 38650	* 17800 * 38650	* 13950 * 30200	10850 23350	* 10700 * 22950	7150 15450			* 8450 * 18550	5850 13000	7020 280
-4500 -180			* 9850 * 20700	* 9850 * 20700					* 7350 * 15950	* 7350 * 15950	5580 220

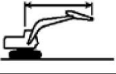















Illustration 77

g03739169

















**335F LCR 6150 mm (242 inch)
Reach Boom with a 3750 mm
(148 inch)Stick and 7700 kg
(16975 lb) Counterweight**

850 mm (33 inch)TG Track Shoes

(mm) (inch)	1500 60		3000 120		4500 180		6000 240		7500 300		9000 360				(mm) (inch)
  															
9000 360							* 13000	* 13000					* 4700	* 4700	6780
													* 10450	* 10450	260
7500 300									* 5700	* 5700			* 4300	* 4300	8040
									* 11700	* 11700			* 9500	* 9500	320
6000 240							* 7000	* 7000	* 6700	6100			* 4150	* 4150	8880
							* 15300	* 15300	* 14500	13050			* 9100	* 9100	350
4500 180					* 9200	* 9200	* 8050	* 8050	* 7200	5900	* 5700	4400	* 4150	4100	9400
					* 19650	* 19650	* 17450	* 17450	* 15600	12750	* 11300	9500	* 9100	9050	370
3000 120					* 12250	12200	* 9350	7950	* 7850	5700	* 6900	4300	* 4250	3850	9660
					* 26400	26250	* 20200	17100	* 17000	12250	* 14150	9250	* 9350	8500	380
1500 60					* 14450	11400	* 10500	7550	* 8450	5500	7100	4200	* 4550	3800	9670
					* 31200	24500	* 22750	16200	* 18350	11800	15250	9050	* 9950	8300	380
0 0			* 6550	* 6550	* 15450	10950	* 11200	7250	* 8850	5300	7000	4150	* 5000	3850	9450
			* 14950	* 14950	* 33400	23550	* 24300	15600	* 19150	11450	15050	8850	* 10950	8450	380
-1500 -60	* 6550	* 6550	* 10250	* 10250	* 15250	10800	* 11300	7100	* 8800	5250			* 5750	4100	8970
	* 14650	* 14650	* 23200	* 23200	* 33000	23200	* 24400	15300	* 19050	11250			* 12650	9050	360
-3000 -120	* 10650	* 10650	* 15300	* 15300	* 14050	10800	* 10550	7100	* 8100	5250			* 7000	4700	8190
	* 23900	* 23900	* 34650	* 34650	* 30350	23250	* 22800	15300	* 17350	11300			* 15350	10350	330
-4500 -180			* 15700	* 15700	* 11600	11000	* 8700	7250					* 6750	5900	7000
			* 33700	* 33700	* 24900	23700	* 18450	15600					* 14850	13200	280

(mm) (inch)	1500 60		3000 120		4500 180		6000 240		7500 300		9000 360				(mm) (inch)	
 																
+2																
9000 360								* 14200	* 14200					* 5150	* 5150	6780
														* 11450	* 11450	260
7500 300									* 6250	6150				* 4700	* 4700	8040
									* 12800	* 12800				* 10400	* 10400	320
6000 240								* 7650	* 7650	* 7350	6100			* 4550	* 4550	8880
								* 16750	* 16750	* 15850	13050			* 10000	* 10000	350
4500 180					* 10050	* 10050	* 8900	8350	* 7950	5900	* 6200	4400	* 4550	4100	9400	
					* 21450	* 21450	* 19250	18000	* 17250	12750	* 12400	9500	* 10000	9050	370	
3000 120					* 13500	12200	* 10300	7950	* 8650	5700	7200	4300	* 4700	3850	9660	
					* 29100	26250	* 22300	17100	* 18800	12250	* 15450	9250	* 10300	8500	380	
1500 60					* 15950	11400	* 11600	7550	9300	5500	7100	4200	* 4950	3800	9670	
					* 34450	24500	* 25100	16200	20000	11800	15250	9050	* 10900	8300	380	
0 0			* 6950	* 6950	* 17050	10950	* 12400	7250	9100	5300	7000	4150	* 5450	3850	9450	
			* 15850	* 15850	* 36900	23550	* 26850	15600	19600	11450	15050	8850	* 12000	8450	380	
-1500 -60	* 6950	* 6950	* 10900	* 10900	* 16850	10800	* 12500	7100	9000	5250			* 6300	4100	8970	
	* 15550	* 15550	* 24600	* 24600	* 36500	23200	* 27000	15300	19400	11250			* 13850	9050	360	
-3000 -120	* 11300	* 11300	* 16200	* 16200	* 15550	10800	* 11700	7100	* 9000	5250			* 7750	4700	8190	
	* 25300	* 25300	* 36700	* 36700	* 33600	23250	* 25250	15300	* 19250	11300			* 17100	10350	330	
-4500 -180			* 17450	* 17450	* 12900	11000	* 9650	7250					* 7550	5900	7000	
			* 37450	* 37450	* 27650	23700	* 20500	15600					* 16550	13200	280	

700 mm (28 inch)TG Track Shoes

(mm) (inch)	1500 60		3000 120		4500 180		6000 240		7500 300		9000 360				(mm) (inch)	
																(mm) (inch)
9000 360							* 13000	* 13000						* 4700	* 4700	6780
														* 10450	* 10450	260
7500 300									* 5700	* 5700				* 4300	* 4300	8040
									* 11700	* 11700				* 9500	* 9500	320
6000 240							* 7000	* 7000	* 6700	5900				* 4150	* 4150	8880
							* 15300	* 15300	* 14500	12700				* 9100	* 9100	350
4500 180					* 9200	* 9200	* 8050	* 8050	* 7200	5750	* 5700	4300	* 4150	4000	9400	
					* 19650	* 19650	* 17450	* 17450	* 15600	12350	* 11300	9200	* 9100	8800	370	
3000 120					* 12250	11850	* 9350	7700	* 7850	5550	* 6900	4200	* 4250	3750	9660	
					* 26400	25550	* 20200	16600	* 17000	11900	* 14150	9000	* 9350	8250	380	
1500 60					* 14450	11050	* 10500	7300	* 8450	5300	6900	4100	* 4550	3650	9670	
					* 31200	23800	* 22750	15750	* 18350	11450	14800	8750	* 9950	8050	380	
0 0			* 6550	* 6550	* 15450	10600	* 11200	7050	* 8850	5150	6800	4000	* 5000	3750	9450	
			* 14950	* 14950	* 33400	22800	* 24300	15150	19050	11100	14600	8600	* 10950	8200	380	
-1500 -60	* 6550	* 6550	* 10250	* 10250	* 15250	10450	* 11300	6900	8750	5050			* 5750	4000	8970	
	* 14650	* 14650	* 23200	* 23200	* 33000	22450	* 24400	14800	18850	10900			* 12650	8750	360	
-3000 -120	* 10650	* 10650	* 15300	* 15300	* 14050	10500	* 10550	6900	* 8100	5050			* 7000	4550	8190	
	* 23900	* 23900	* 34650	* 34650	* 30350	22550	* 22800	14800	* 17350	10950			* 15350	10050	330	
-4500 -180			* 15700	* 15700	* 11600	10700	* 8700	7000					* 6750	5750	7000	
			* 33700	* 33700	* 24900	23000	* 18450	15150					* 14850	12800	280	



























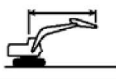



(mm) (inch)	1500 60		3000 120		4500 180		6000 240		7500 300		9000 360				(mm) (inch)	
																
+2																
9000 360								* 14200	* 14200					* 5150	* 5150	6780
														* 11450	* 11450	260
7500 300										* 6250	6000			* 4700	* 4700	8040
										* 12800	12800			* 10400	* 10400	320
6000 240								* 7650	* 7650	* 7350	5900			* 4550	4450	8880
								* 16750	* 16750	* 15850	12700			* 10000	9850	350
4500 180					* 10050	* 10050	* 8900	8150	* 7950	5750	* 6200	4300	* 4550	4000	9400	
					* 21450	* 21450	* 19250	17500	* 17250	12350	* 12400	9200	* 10000	8800	370	
3000 120					* 13500	11850	* 10300	7700	* 8650	5550	7000	4200	* 4700	3750	9660	
					* 29100	25550	* 22300	16600	* 18800	11900	15050	9000	* 10300	8250	380	
1500 60					* 15950	11050	* 11600	7300	9050	5300	6900	4100	* 4950	3650	9670	
					* 34450	23800	* 25100	15750	19450	11450	14800	8750	* 10900	8050	380	
0 0			* 6950	* 6950	* 17050	10600	* 12400	7050	8850	5150	6800	4000	* 5450	3750	9450	
			* 15850	* 15850	* 36900	22800	26700	15150	19050	11100	14600	8600	* 12000	8200	380	
-1500	* 6950	* 6950	* 10900	* 10900	* 16850	10450	12250	6900	8750	5050			* 6300	4000	8970	
-60	* 15550	* 15550	* 24600	* 24600	* 36500	22450	26300	14800	18850	10900			* 13850	8750	360	
-3000	* 11300	* 11300	* 16200	* 16200	* 15550	10500	* 11700	6900	8750	5050			* 7750	4550	8190	
-120	* 25300	* 25300	* 36700	* 36700	* 33600	22550	* 25250	14800	18850	10950			* 17100	10050	330	
-4500			* 17450	* 17450	* 12900	10700	* 9650	7000					* 7550	5750	7000	
-180			* 37450	* 37450	* 27650	23000	* 20500	15150					* 16550	12800	280	

Illustration 81

g03739175

600 mm (24 inch) TG Track Shoes

(mm) (inch)	1500 60	3000 120	4500 180	6000 240	7500 300	9000 360							(mm) (inch)				
																	
9000 360								* 13000	* 13000					* 4700	* 4700	6780	
7500 300										* 5700	* 5700			* 4300	* 4300	8040	
6000 240								* 7000	* 7000	* 6700	5850			* 4150	* 4150	8880	
4500 180								* 15300	* 15300	* 14500	12600			* 9100	* 9100	350	
3000 120								* 9200	* 9200	* 8050	* 8050	* 7200	5700	* 5700	4250	* 4150	3950
1500 60								* 19650	* 19650	* 17450	17350	* 15600	12250	* 11300	9100	* 9100	8700
0								* 12250	11750	* 9350	7650	* 7850	5500	* 6900	4150	* 4250	3700
-1500	* 6550	* 6550	* 10250	* 10250	* 15250	10350	* 11300	6800	8650	5000				* 5750	3950	8970	
-3000	* 14650	* 14650	* 23200	* 23200	* 33000	22250	* 24400	14650	18650	10750				* 12650	8650	360	
-4500	* 10650	* 10650	* 15300	* 15300	* 14050	10400	* 10550	6800	* 8100	5000				* 7000	4500	8190	
-180	* 23900	* 23900	* 34650	* 34650	* 30350	22300	* 22800	14650	* 17350	10800				* 15350	9900	330	
			* 15700	* 15700	* 11600	10600	* 8700	6950						* 6750	5650	7000	
			* 33700	* 33700	* 24900	22750	* 18450	15000						* 14850	12650	280	











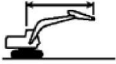







(mm) (inch)	1500 60		3000 120		4500 180		6000 240		7500 300		9000 360				(mm) (inch)	
  																
+Z																
9000 360								* 14200	* 14200					* 5150	* 5150	6780
														* 11450	* 11450	260
7500 300									* 6250	5900				* 4700	* 4700	8040
									* 12800	12650				* 10400	* 10400	320
6000 240								* 7650	* 7650	* 7350	5850			* 4550	4400	8880
								* 16750	* 16750	* 15850	12600			* 10000	9750	350
4500 180					* 10050	* 10050	* 8900	8050	* 7950	5700	* 6200	4250	* 4550	3950	9400	
					* 21450	* 21450	* 19250	17350	* 17250	12250	* 12400	9100	* 10000	8700	370	
3000 120					* 13500	11750	* 10300	7650	* 8650	5500	6950	4150	* 4700	3700	9660	
					* 29100	25300	* 22300	16450	* 18800	11800	14900	8900	* 10300	8150	380	
1500 60					* 15950	10950	* 11600	7250	8950	5250	6800	4050	* 4950	3600	9670	
					* 34450	23600	* 25100	15600	19250	11300	14650	8650	* 10900	7950	380	
0 0			* 6950	* 6950	* 17050	10500	12300	6950	8750	5100	6700	3950	* 5450	3700	9450	
			* 15850	* 15850	* 36900	22600	26400	14950	18850	10950	14450	8500	* 12000	8100	380	
-1500 -60	* 6950	* 6950	* 10900	* 10900	* 16850	10350	12150	6800	8650	5000			* 6300	3950	8970	
	* 15550	* 15550	* 24600	* 24600	* 36500	22250	26050	14650	18650	10750			* 13850	8650	360	
-3000 -120	* 11300	* 11300	* 16200	* 16200	* 15550	10400	* 11700	6800	8700	5000			7700	4500	8190	
	* 25300	* 25300	* 36700	* 36700	* 33600	22300	* 25250	14650	18700	10800			17000	9900	330	
-4500 -180			* 17450	* 17450	* 12900	10600	* 9650	6950					* 7550	5650	7000	
			* 37450	* 37450	* 27650	22750	* 20500	15000					* 16550	12650	280	

Illustration 83

g03739178

**335F LC BLADE UP 6150 mm
(242 inch) Reach Boom with a
3200 mm (126 inch) Stick and
7700 kg (16975 lb) Counterweight**

Product Information Section
Lifting Capacities

850 mm (33 inch) TG Track Shoe











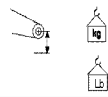





(mm) (inch)	1500 60		3000 120		4500 180		6000 240		7500 300		9000 360				(mm) (inch)	
																
																
9000 360							* 5800	* 5800						* 5650	* 5650	6040
														* 12650	* 12650	230
7500 300							* 7350	* 7350						* 5100	* 5100	7440
							* 16200	* 16200						* 11250	* 11250	290
6000 240							* 7800	* 7800	* 7300	6550				* 4900	* 4900	8330
							* 17000	* 17000	* 15900	14050				* 10750	* 10750	330
4500 180			* 15550	* 15550	* 10800	* 10800	* 8800	* 8800	* 7700	6400				* 4900	* 4900	8890
			* 33000	* 33000	* 23200	* 23200	* 19000	* 19000	* 16800	13800				* 10700	* 10700	350
3000 120					* 13350	12950	* 10000	8550	* 8300	6200	* 6150	4750		* 5050	4650	9160
					* 28750	27950	* 21600	18400	* 18000	13350	* 11200	10200		* 11050	10200	360
1500 60					* 15200	12300	* 11000	8200	* 8800	6050	* 6850	4650		* 5350	4550	9180
					* 32850	26450	* 23800	17650	* 19100	13000	* 12450	10050		* 11750	10000	370
0 0			* 5700	* 5700	* 15700	12000	* 11500	7950	* 9050	5900				* 5950	4650	8950
			* 13100	* 13100	* 33950	25750	* 24900	17150	* 19600	12700				* 13050	10250	360
-1500 -60	* 7100	* 7100	* 10800	* 10800	* 15050	11900	* 11300	7900	* 8800	5850				* 6900	5050	8440
	* 15850	* 15850	* 24450	* 24450	* 32650	25600	* 24450	16950	* 19000	12600				* 15250	11050	340
-3000 -120			* 17250	* 17250	* 13450	12000	* 10250	7900	* 7600	5900				* 7400	5800	7600
			* 39150	* 39150	* 29050	25800	* 22050	17050						* 16200	12900	300
-4500 -180			* 13550	* 13550	* 10450	* 10450	* 7550	* 7550						* 6900	* 6900	6300
			* 28950	* 28950	* 22200	* 22200	* 15700	* 15700						* 15050	* 15050	250

Illustration 84

g03384860











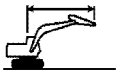















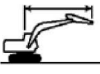





(mm) (inch)	1500 60		3000 120		4500 180		6000 240		7500 300		9000 360					
 														(mm) (inch)		
																
9000 360							* 6350	* 6350						* 6200 * 13800	* 6200 * 13800	6040 230
7500 300							* 8100	* 8100						* 5550 * 12300	* 5550 * 12300	7440 290
6000 240							* 8600	* 8600	* 8050	6550				* 5350 * 11750	* 5350 * 11750	8330 330
4500 180			* 17050	* 17050	* 11850	* 11850	* 9650	8950	* 8500	6400				* 5350 * 11750	4950 10900	8890 350
3000 120					* 14700	12950	* 11000	8550	* 9150	6200	* 6750	4750		* 5500 * 12100	4650 10200	9160 360
1500 60					* 16750	12300	* 12150	8200	9450	6050	7250	4650		* 5850 * 12900	4550 10000	9180 370
0 0			* 6050	* 6050	* 17300	12000	* 12700	7950	9300	5900				* 6500 * 14300	4650 10250	8950 360
-1500 -60	* 7550	* 7550	* 11450	* 11450	* 16650	11900	* 12500	7900	9250	5850				* 7550 * 16700	5050 11050	8440 340
-3000 -120			* 18300	* 18300	* 14850	12000	* 11300	7900	* 8400	5900				* 8200 * 18000	5800 12900	7600 300
-4500 -180			* 15050	* 15050	* 11550	* 11550	* 8400	8150						* 7650 * 16750	7650 16750	6300 250

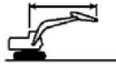

















Illustration 85

g03384868

Product Information Section
Lifting Capacities











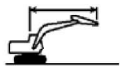





700 mm (28 inch) TG Track Shoe

(mm) (inch)	1500 60		3000 120		4500 180		6000 240		7500 300		9000 360					
															(mm) (inch)	
																
9000 360							* 5800	* 5800						* 5650	* 5650	6040 230
7500 300							* 7350	* 7350						* 5100	* 5100	7440 290
6000 240							* 7800	* 7800	* 7300	6400				* 4900	* 4900	8330 330
4500 180			* 15550	* 15550	* 10800	* 10800	* 8800	8700	* 7700	6250				* 4900	4800	8890 350
3000 120			* 33000	* 33000	* 23200	* 23200	* 19000	18750	* 16800	13400				* 10750	* 10750	
1500 60					* 13350	12650	* 10000	8350	* 8300	6050	* 6150	4600	* 5050	4500	9160 360	
0 0					* 28750	27250	* 21600	17950	* 18000	13000	* 11200	9900	* 11050	9900		
-1500 -60	* 7100	* 7100	* 10800	* 10800	* 15200	11950	* 11000	8000	* 8800	5850	* 6850	4550	* 5350	4400	9180 370	
-3000 -120			* 32850	25750	* 23800	17200	* 19100	12600	* 12450	9750			* 11750	9700		
-4500 -180			* 5700	* 5700	* 15700	11650	* 11500	7750	9050	5750			* 5950	4550	8950 360	
			* 13100	* 13100	* 33950	25050	* 24900	16700	19400	12350			* 13050	9950		
	* 7100	* 7100	* 10800	* 10800	* 15050	11600	* 11300	7650	* 8800	5650			* 6900	4900	8440 340	
	* 15850	* 15850	* 24450	* 24450	* 32650	24900	* 24450	16500	* 19000	12200			* 15250	10750		
			* 17250	* 17250	* 13450	11650	* 10250	7700	* 7600	5750			* 7400	5650	7600 300	
			* 39150	* 39150	* 29050	25100	* 22050	16600					* 16200	12500		
			* 13550	* 13550	* 10450	* 10450	* 7550	* 7550					* 6900	* 6900	6300 250	
			* 28950	* 28950	* 22200	* 22200	* 15700	* 15700					* 15050	* 15050		

(mm) (inch)	1500 60		3000 120		4500 180		6000 240		7500 300		9000 360				(mm) (inch)	
  																
+2 																
9000 360							* 6350	* 6350						* 6200	* 6200	6040
7500 300							* 8100	* 8100						* 5550	* 5550	7440
6000 240							* 17800	* 17800						* 12300	* 12300	290
4500 180							* 8600	* 8600	* 8050	6400				* 5350	* 5350	8330
3000 120							* 18700	* 18700	* 17350	13700				* 11750	* 11750	330
1500 60							* 9650	8700	* 8500	6250				* 5350	4800	8890
0 0							* 20950	18750	* 18550	13400				* 11750	10600	350
-1500 -60	* 7550	* 7550	* 11450	* 11450	* 16650	11600	* 12500	7650	8950	5650				* 7550	4900	8440
-3000 -120	* 16800	* 16800	* 25900	* 25900	* 36050	24900	26900	16500	19300	12200				* 16700	10750	340
-4500 -180			* 18300	* 18300	* 14850	11650	* 11300	7700	* 8400	5750				* 8200	5650	7600
			* 41500	* 41500	* 32150	25100	* 24400	16600						* 18000	12500	300
			* 15050	* 15050	* 11550	* 11550	* 8400	7900						* 7650	7450	6300
			* 32200	* 32200	* 24650	* 24650	* 17450	17100						* 16750	16700	250

Product Information Section
Lifting Capacities

600 mm (24 inch) TG Track Shoe

(mm) (inch)	1500 60		3000 120		4500 180		6000 240		7500 300		9000 360				(mm) (inch)	
																
																
9000 360							* 5800	* 5800						* 5650	* 5650	6040
														* 12650	* 12650	230
7500 300							* 7350	* 7350						* 5100	* 5100	7440
							* 16200	* 16200						* 11250	* 11250	290
6000 240							* 7800	* 7800	* 7300	6350				* 4900	* 4900	8330
							* 17000	* 17000	* 15900	13600				* 10750	* 10750	330
4500 180			* 15550	* 15550	* 10800	* 10800	* 8800	8650	* 7700	6200				* 4900	4750	8890
			* 33000	* 33000	* 23200	* 23200	* 19000	18600	* 16800	13300				* 10700	10500	350
3000 120					* 13350	12500	* 10000	8250	* 8300	6000	* 6150	4600		* 5050	4450	9160
					* 28750	27000	* 21600	17800	* 18000	12900	* 11200	9800		* 11050	9800	360
1500 60					* 15200	11850	* 11000	7900	* 8800	5800	* 6850	4500		* 5350	4350	9180
					* 32850	25500	* 23800	17050	* 19100	12500	* 12450	9650		* 11750	9600	370
0 0			* 5700	* 5700	* 15700	11550	* 11500	7700	8950	5650				* 5950	4500	8950
			* 13100	* 13100	* 33950	24800	* 24900	16550	19250	12200				* 13050	9850	360
-1500 -60	* 7100	* 7100	* 10800	* 10800	* 15050	11450	* 11300	7600	* 8800	5600				* 6900	4850	8440
	* 15850	* 15850	* 24450	* 24450	* 32650	24650	* 24450	16350	* 19000	12100				* 15250	10650	340
-3000 -120			* 17250	* 17250	* 13450	11550	* 10250	7600	* 7600	5700				* 7400	5600	7600
			* 39150	* 39150	* 29050	24850	* 22050	16400						* 16200	12400	300
-4500 -180			* 13550	* 13550	* 10450	* 10450	* 7550	* 7550						* 6900	* 6900	6300
			* 28950	* 28950	* 22200	* 22200	* 15700	* 15700						* 15050	* 15050	250











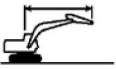















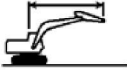
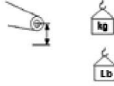



(mm) (inch)	1500 60		3000 120		4500 180		6000 240		7500 300		9000 360				(mm) (inch)	
																
+2 																
9000 360								* 6350	* 6350					* 6200	* 6200	6040
														* 13800	* 13800	230
7500 300								* 8100	* 8100					* 5550	* 5550	7440
								* 17800	* 17800					* 12300	* 12300	290
6000 240								* 8600	* 8600	* 8050	6350			* 5350	5300	8330
								* 18700	* 18700	* 17350	13600			* 11750	* 11750	330
4500 180			* 17050	* 17050	* 11850	* 11850	* 9650	8650	* 8500	6200			* 5350	4750	8890	
			* 36150	* 36150	* 25500	* 25500	* 20950	18600	* 18550	13300			* 11750	10500	350	
3000 120					* 14700	12500	* 11000	8250	* 9150	6000	* 6750	4600	* 5500	4450	9160	
					* 31700	27000	* 23800	17800	* 19900	12900	* 12250	9800	* 12100	9800	360	
1500 60					* 16750	11850	* 12150	7900	9100	5800	6950	4500	* 5850	4350	9180	
					* 36200	25500	* 26250	17050	19550	12500	* 13600	9650	* 12900	9600	370	
0 0			* 6050	* 6050	* 17300	11550	12500	7700	8950	5650			* 6500	4500	8950	
			* 13900	* 13900	* 37500	24800	26850	16550	19250	12200			* 14300	9850	360	
-1500 -60	* 7550	* 7550	* 11450	* 11450	* 16650	11450	12400	7600	8900	5600			7550	4850	8440	
	* 16800	* 16800	* 25900	* 25900	* 36050	24650	26600	16350	19100	12100			16650	10650	340	
-3000 -120			* 18300	* 18300	* 14850	11550	* 11300	7600	* 8400	5700			* 8200	5600	7600	
			* 41500	* 41500	* 32150	24850	* 24400	16400					* 18000	12400	300	
-4500 -180			* 15050	* 15050	* 11550	* 11550	* 8400	7850					* 7650	7350	6300	
			* 32200	* 32200	* 24650	* 24650	* 17450	16950					* 16750	16550	250	

Illustration 89

g03739198

**335F LC BLADE UP 6150 mm
(242 inch) Reach Boom with a
2650 mm (104 inch) Stick and
7700 kg (16975 lb) Counterweight**

850 mm (33 inch) TG Track Shoe

(mm) (inch)	1500 60		3000 120		4500 180		6000 240		7500 300				(mm) (inch)	
														
														
9000 360												* 7600 * 17100	* 7600 * 17100	5290 200
7500 300							* 8200 * 18000	* 8200 * 18000				* 6650 * 14750	* 6650 * 14750	6850 270
6000 240							* 8500 * 18550	* 8500 * 18550	* 7950 * 16200	6500 13950		* 6300 * 13900	6100 13550	7810 310
4500 180					* 11900 * 25600	* 11900 * 25600	* 9450 * 20450	8900 19150	* 8200 * 17900	6400 13800		* 6250 * 13800	5400 11900	8400 330
3000 120					* 14400 * 30950	12800 27650	* 10550 * 22850	8550 18400	* 8700 * 18900	6250 13450		* 6450 * 14200	5050 11100	8690 350
1500 60					* 15200 * 34100	12300 26450	* 11400 * 24700	8250 17750	* 9100 * 19750	6100 13100		* 6900 * 15100	4950 10900	8710 350
0 0					* 15700 * 34100	12100 26050	* 11700 * 25300	8050 17350	* 9200 * 19850	6000 12900		* 7650 * 16800	5100 11250	8460 340
-1500 -60			* 10850 * 24750	* 10850 * 24750	* 14700 * 31850	12100 26050	* 11200 * 24200	8000 17300	* 8600 * 18500	5950 12900		* 7900 * 17350	5600 12300	7920 320
-3000 -120			* 16100 * 34950	* 16100 * 34950	* 12650 * 27300	12250 26350	* 9700 * 20750	8100 17450				* 7600 * 16750	6600 14700	7020 280
-4500 -180					* 8850 * 18600	* 8850 * 18600						* 6600 * 14300	* 6600 * 14300	5580 220











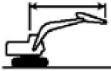



(mm) (inch)	1500 60		3000 120		4500 180		6000 240		7500 300				(mm) (inch)	
														
														
9000 360												* 8300 * 18600	* 8300 * 18600	5290 200
7500 300							* 9000 * 19750	* 9000 * 19750				* 7250 * 16100	* 7250 * 16100	6850 270
6000 240							* 9350 * 20400	9200 19750	* 8750 * 17650	6500 13950		* 6900 * 15200	6100 13550	7810 310
4500 180					* 13100 * 28150	* 13100 * 28150	* 10400 * 22500	8900 19150	* 9050 * 19700	6400 13800		* 6850 * 15050	5400 11900	8400 330
3000 120					* 15850 * 34050	12800 27650	* 11650 * 25150	8550 18400	* 9600 20800	6250 13450		* 7050 * 15500	5050 11100	8690 350
1500 60					* 16050 * 37550	12300 26450	* 12600 * 27250	8250 17750	9500 20450	6100 13100		* 7500 * 16500	4950 10900	8710 350
0 0					* 17300 * 37550	12100 26050	* 12900 * 27900	8050 17350	9400 20200	6000 12900		7950 17450	5100 11250	8460 340
-1500 -60			* 11500 * 26200	* 11500 * 26200	* 16200 * 35150	12100 26050	* 12350 * 26700	8000 17300	9350 20200	5950 12900		8700 * 19150	5600 12300	7920 320
-3000 -120			* 17800 * 38650	* 17800 * 38650	* 13950 * 30200	12250 26350	* 10700 * 22950	8100 17450				* 8450 * 18550	6600 14700	7020 280
-4500 -180					* 9850 * 20700	* 9850 * 20700						* 7350 * 15950	* 7350 * 15950	5580 220

Illustration 91

g03739202

Product Information Section
Lifting Capacities

700 mm (28 inch) TG Track Shoe

















(mm) (inch)	1500 60		3000 120		4500 180		6000 240		7500 300				(mm) (inch)	
  														
														
9000 360												* 7600 * 17100	* 7600 * 17100	5290 200
7500 300							* 8200 * 18000	* 8200 * 18000				* 6650 * 14750	* 6650 * 14750	6850 270
6000 240							* 8500 * 18550	* 8500 * 18550	* 7950 * 16200	6350 13600		* 6300 * 13900	5950 13200	7810 310
4500 180					* 11900 * 25600	* 11900 * 25600	* 9450 * 20450	8650 18650	* 8200 * 17900	6250 13400		* 6250 * 13800	5250 11600	8400 330
3000 120					* 14400 * 30950	12500 26950	* 10550 * 22850	8300 17900	* 8700 * 18900	6050 13100		* 6450 * 14200	4900 10800	8690 350
1500 60					* 15200 * 34100	11950 25750	* 11400 * 24700	8000 17250	* 9100 * 19750	5900 12750		* 6900 * 15100	4850 10600	8710 350
0 0					* 15700 * 34100	11800 25350	* 11700 * 25300	7850 16900	9100 19600	5800 12550		* 7650 * 16800	4950 10950	8460 340
-1500 -60			* 10850 * 24750	* 10850 * 24750	* 14700 * 31850	11800 25350	* 11200 * 24200	7800 16800	* 8600 * 18500	5800 12500		* 7900 * 17350	5450 11950	7920 320
-3000 -120			* 16100 * 34950	* 16100 * 34950	* 12650 * 27300	11900 25650	* 9700 * 20750	7900 17000				* 7600 * 16750	6450 14250	7020 280
-4500 -180					* 8850 * 18600	* 8850 * 18600						* 6600 * 14300	* 6600 * 14300	5580 220

Illustration 92

g03739207











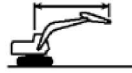
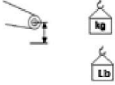



(mm) (inch)	1500 60		3000 120		4500 180		6000 240		7500 300				(mm) (inch)	
														
														
9000 360												* 8300 * 18600	* 8300 * 18600	5290 200
7500 300							* 9000 * 19750	* 9000 19500				* 7250 * 16100	* 7250 * 16100	6850 270
6000 240							* 9350 * 20400	8950 19300	* 8750 * 17650	6350 13600		* 6900 * 15200	5950 13200	7810 310
4500 180					* 13100 * 28150	* 13100 * 28150	* 10400 * 22500	8650 18650	* 9050 * 19700	6250 13400		* 6850 * 15050	5250 11600	8400 330
3000 120					* 15850 * 34050	12500 26950	* 11650 * 25150	8300 17900	9400 20200	6050 13100		* 7050 * 15500	4900 10800	8690 350
1500 60					* 16050 * 37550	11950 25750	* 12600 * 27250	8000 17250	9250 19850	5900 12750		7450 16350	4850 10600	8710 350
0 0					* 17300 * 37550	11800 25350	12700 27300	7850 16900	9100 19600	5800 12550		7700 16950	4950 10950	8460 340
-1500 -60			* 11500 * 26200	* 11500 * 26200	* 16200 * 35150	11800 25350	* 12350 * 26700	7800 16800	9100 19600	5800 12500		8450 18650	5450 11950	7920 320
-3000 -120			* 17800 * 38650	* 17800 * 38650	* 13950 * 30200	11900 25650	* 10700 * 22950	7900 17000				* 8450 * 18550	6450 14250	7020 280
-4500 -180					* 9850 * 20700	* 9850 * 20700						* 7350 * 15950	* 7350 * 15950	5580 220

Illustration 93

g03739208

Product Information Section
Lifting Capacities

600 mm (24 inch) TG Track Shoe











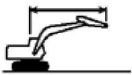
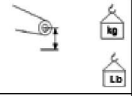



(mm) (inch)	1500 60		3000 120		4500 180		6000 240		7500 300				(mm) (inch)	
														
														
9000 360												* 7600 * 17100	* 7600 * 17100	5290 200
7500 300							* 8200 * 18000	* 8200 * 18000				* 6650 * 14750	* 6650 * 14750	6850 270
6000 240							* 8500 * 18550	* 8500 * 18550	* 7950 * 16200	6300 13500	* 6300 * 13900	5900 13100	7810 310	
4500 180					* 11900 * 25600	* 11900 * 25600	* 9450 * 20450	8600 18500	* 8200 * 17900	6200 13300	* 6250 * 13800	5200 11500	8400 330	
3000 120					* 14400 * 30950	12400 26700	* 10550 * 22850	8250 17750	* 8700 * 18900	6000 12950	* 6450 * 14200	4850 10700	8690 350	
1500 60					* 15200 * 34100	11850 25550	* 11400 * 24700	7950 17100	* 9100 19650	5850 12650	* 6900 * 15100	4800 10500	8710 350	
0 0					* 15700 * 34100	11650 25100	* 11700 * 25300	7750 16750	9050 19400	5750 12400	7600 16750	4950 10850	8460 340	
-1500 -60			* 10850 * 24750	* 10850 * 24750	* 14700 * 31850	11650 25100	* 11200 * 24200	7750 16650	* 8600 * 18500	5750 12400	* 7900 * 17350	5400 11850	7920 320	
-3000 -120			* 16100 * 34950	* 16100 * 34950	* 12650 * 27300	11800 25400	* 9700 * 20750	7800 16850			* 7600 * 16750	6400 14150	7020 280	
-4500 -180					* 8850 * 18600	* 8850 * 18600					* 6600 * 14300	* 6600 * 14300	5580 220	

Illustration 94















(mm) (inch)	1500 60		3000 120		4500 180		6000 240		7500 300				(mm) (inch)	
														
+2 														
9000 360												* 8300 * 18600	* 8300 * 18600	5290 200
7500 300							* 9000 * 19750	* 9000 19350				* 7250 * 16100	* 7250 * 16100	6850 270
6000 240							* 9350 * 20400	8900 19100	* 8750 * 17650	6300 13500		* 6900 * 15200	5900 13100	7810 310
4500 180					* 13100 * 28150	* 13100 * 28150	* 10400 * 22500	8600 18500	* 9050 * 19700	6200 13300		* 6850 * 15050	5200 11500	8400 330
3000 120					* 15850 * 34050	12400 26700	* 11650 * 25150	8250 17750	9300 20000	6000 12950		* 7050 * 15500	4850 10700	8690 350
1500 60					* 16050 * 37550	11850 25550	* 12600 * 27250	7950 17100	9150 19650	5850 12650		7350 16200	4800 10500	8710 350
0 0					* 17300 * 37550	11650 25100	12600 27050	7750 16750	9050 19400	5750 12400		7600 16750	4950 10850	8460 340
-1500 -60			* 11500 * 26200	* 11500 * 26200	* 16200 * 35150	11650 25100	* 12350 * 26700	7750 16650	9000 19400	5750 12400		8350 18450	5400 11850	7920 320
-3000 -120			* 17800 * 38650	* 17800 * 38650	* 13950 * 30200	11800 25400	* 10700 * 22950	7800 16850				* 8450 * 18550	6400 14150	7020 280
-4500 -180					* 9850 * 20700	* 9850 * 20700						* 7350 * 15950	* 7350 * 15950	5580 220

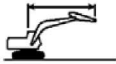













Illustration 95

g03739213

**335F LCRBLADE UP 6150 mm
(242 inch) Reach Boom with a
3750 mm (148 inch) Stick and
7700 kg (16975 lb) Counterweight**

Product Information Section
Lifting Capacities

850 mm (33 inch) TG Track Shoe

(mm) (inch)	1500 60		3000 120		4500 180		6000 240		7500 300		9000 360				(mm) (inch)		
																	
9000 360								* 13000	* 13000					* 4700	* 4700	6780	
7500 300										* 5700	* 5700			* 4300	* 4300	8040	
6000 240								* 7000	* 7000	* 6700	6550			* 4150	* 4150	8880	
4500 180					* 9200	* 9200	* 8050	* 8050	* 7200	6400	* 5700	4800		* 4150	* 4150	9400	
3000 120					* 19650	* 19650	* 17450	* 17450	* 15600	13750	* 11300	10300		* 9100	* 9100	370	
1500 60					* 12250	* 12250	* 9350	8650	* 7850	6200	* 6900	4700		* 4250	4200	9660	
0					* 26400	* 26400	* 20200	18450	* 17000	13300	* 14150	10100		* 9350	9300	380	
-1500 -60					* 14450	12350	* 10500	8150	* 8450	5950	7150	4600		* 4550	4150	9670	
-3000 -120					* 31200	26550	* 22750	17600	* 18350	12850	15400	9850		* 9950	9100	380	
-4500 -180					* 6550	* 6550	* 15450	11900	* 11200	7900	* 8850	5800	7050	4500	* 5000	4200	9450
					* 14950	* 14950	* 33400	25550	* 24300	17000	* 19150	12500	15200	9700	* 10950	9250	390
	* 6550	* 6550	* 10250	* 10250	* 15250	11700	* 11300	7750	* 8800	5700				* 5750	4500	8970	
	* 14650	* 14650	* 23200	* 23200	* 33000	25200	* 24400	16650	* 19050	12300				* 12650	9900	360	
	* 10650	* 10650	* 15300	* 15300	* 14050	11750	* 10550	7750	* 8100	5700				* 7000	5100	8190	
	* 23900	* 23900	* 34650	* 34650	* 30350	25300	* 22800	16650	* 17350	12350				* 15350	11300	330	
			* 15700	* 15700	* 11600	* 11600	* 8700	7850						* 6750	6450	7000	
			* 33700	* 33700	* 24900	* 24900	* 18450	17000						* 14850	14350	290	











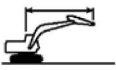

















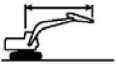



(mm) (inch)	1500 60		3000 120		4500 180		6000 240		7500 300		9000 360				(mm) (inch)
 															
															
9000 360							* 14200	* 14200					* 5150	* 5150	6780
7500 300									* 6250	* 6250			* 4700	* 4700	8040
6000 240							* 7650	* 7650	* 7350	6550			* 10400	* 10400	320
4500 180					* 10050	* 10050	* 8900	* 8900	* 7950	6400	* 6200	4800	* 4550	4500	9400
3000 120					* 21450	* 21450	* 19250	* 19250	* 17250	13750	* 12400	10300	* 10000	9900	370
1500 60					* 13500	13150	* 10300	8550	* 8650	6200	7300	4700	* 4700	4200	9660
0 0					* 29100	28300	* 22300	18450	* 18800	13300	* 15450	10100	* 10300	9300	380
-1500 -60	* 6950	* 6950	* 10900	* 10900	* 15950	12350	* 11600	8150	* 9350	5950	7150	4600	* 4950	4150	9670
-3000 -120	* 15550	* 15550	* 24600	* 24600	* 34450	26550	* 25100	17600	20200	12950	15400	9950	* 10900	9100	380
-4500 -180			* 6950	* 6950	* 17050	11900	* 12400	7900	9200	5800	7050	4500	* 5450	4200	9450
			* 15850	* 15850	* 36900	25550	* 26850	17000	19800	12500	15200	9700	* 12000	9250	380
	* 6950	* 6950	* 10900	* 10900	* 16850	11700	* 12500	7750	9100	5700			* 6300	4500	8970
	* 15550	* 15550	* 24600	* 24600	* 36500	25200	* 27000	16650	19600	12300			* 13950	9900	360
	* 11300	* 11300	* 16200	* 16200	* 15550	11750	* 11700	7750	* 9000	5700			* 7750	5100	8190
	* 25300	* 25300	* 36700	* 36700	* 33600	25300	* 25250	16650	* 19250	12350			* 17100	11300	330
			* 17450	* 17450	* 12900	11950	* 9650	7850					* 7550	6450	7000
			* 37450	* 37450	* 27650	25750	* 20500	17000					* 16550	14350	280

Illustration 97

g03739218

700 mm (28 inch) TG Track Shoe

[mm] (inch)	1500 60		3000 120		4500 180		6000 240		7500 300		9000 360				[mm] (inch)
															
9000 360							* 13000	* 13000					* 4700	* 4700	6780
7500 300									* 5700	* 5700			* 4300	* 4300	8040
6000 240							* 7000	* 7000	* 6700	6400			* 4150	* 4150	8880
4500 180					* 9200	* 9200	* 8050	* 8050	* 7200	6250	* 5700	4650	* 4150	* 4150	9400
3000 120					* 19650	* 19650	* 17450	* 17450	* 15600	13400	* 11300	10000	* 9100	* 9100	370
1500 60					* 12250	* 12250	* 9350	8350	* 7850	6000	* 6900	4550	* 4250	4100	9660
0 0					* 26400	* 26400	* 20200	18000	* 17000	12950	* 14150	9800	* 9350	9000	380
-1500 -60	* 6550	* 6550	* 10250	* 10250	* 14450	12000	* 10500	7950	* 8450	5800	6950	4450	* 4550	4000	9670
-3000 -120	* 14950	* 14950	* 33400	24850	* 31200	25850	* 22750	17100	* 18350	12500	14950	9600	* 9950	8800	380
-4500 -180			* 6550	* 6550	* 15450	11550	* 11200	7650	* 8850	5650	6850	4400	* 5000	4100	9450
			* 14950	* 14950	* 33400	24850	* 24300	16500	* 19150	12100	14750	9400	* 10950	9000	380
	* 6550	* 6550	* 10250	* 10250	* 15250	11400	* 11300	7500	* 8800	5550			* 5750	4350	8970
	* 14650	* 14650	* 23200	* 23200	* 33000	24500	* 24400	16200	19000	11950			* 12650	9650	360
	* 10650	* 10650	* 15300	* 15300	* 14050	11450	* 10550	7500	* 8100	5550			* 7000	4950	8190
	* 23900	* 23900	* 34650	* 34650	* 30350	24550	* 22800	16200	* 17350	11950			* 15350	11000	330
			* 15700	* 15700	* 11600	* 11600	* 8700	7650					* 6750	6250	7000
			* 33700	* 33700	* 24900	* 24900	* 18450	16500					* 14850	13950	280











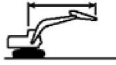















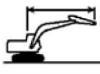





(mm) (inch)	1500 60		3000 120		4500 180		6000 240		7500 300		9000 360				(mm) (inch)	
																
 + 																
9000 360								* 14200	* 14200					* 5150	* 5150	6780
7500 300										* 6250	* 6250			* 4700	* 4700	8040
6000 240								* 7650	* 7650	* 7350	6400			* 4550	* 4550	8880
4500 180								* 16750	* 16750	* 15850	13750			* 10000	* 10000	350
3000 120										* 7950	6250	* 6200	4650	* 4550	4350	9400
1500 60										* 17250	13400	* 12400	10000	* 10000	9600	370
0										* 8650	6000	7050	4550	* 4700	4100	9660
-1500	* 6950	* 6950	* 10900	* 10900	* 16850	11400	12350	7500	8850	5550				* 6300	4350	8970
-60	* 15550	* 15550	* 24600	* 24600	* 36500	24500	26600	16200	19000	11950				* 13850	9650	360
-3000	* 11300	* 11300	* 16200	* 16200	* 15550	11450	* 11700	7500	8850	5550				* 7750	4950	8190
-120	* 25300	* 25300	* 36700	* 36700	* 33600	24550	* 25250	16200	19050	11950				* 17100	11000	330
-4500			* 17450	* 17450	* 12900	11650	* 9650	7650						* 7550	6250	7000
-180			* 37450	* 37450	* 27650	25050	* 20500	16500						* 16550	13950	280

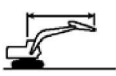

















Illustration 99

g03739222

Product Information Section
Lifting Capacities

600 mm (24 inch) TG Track Shoe

(mm) (inch)	1500 60		3000 120		4500 180		6000 240		7500 300		9000 360				(mm) (inch)	
																
																
9000 360							* 13000	* 13000						* 4700	* 4700	6780
														* 10450	* 10450	260
7500 300									* 5700	* 5700				* 4300	* 4300	8040
									* 11700	* 11700				* 9500	* 9500	320
6000 240							* 7000	* 7000	* 6700	6350				* 4150	* 4150	8880
							* 15300	* 15300	* 14500	13600				* 9100	* 9100	350
4500 180					* 9200	* 9200	* 8050	* 8050	* 7200	6200	* 5700	4650		* 4150	* 4150	9400
					* 19650	* 19650	* 17450	* 17450	* 15600	13300	* 11300	9900		* 9100	* 9100	370
3000 120					* 12250	* 12250	* 9350	8250	* 7850	5950	* 6900	4550		* 4250	4050	9660
					* 26400	* 26400	* 20200	17800	* 17000	12800	* 14150	9700		* 9350	8900	380
1500 60					* 14450	11900	* 10500	7850	* 8450	5750	6900	4400		* 4550	3950	9670
					* 31200	25600	* 22750	16950	* 18350	12350	14800	9500		* 9950	8750	380
0 0			* 6550	* 6550	* 15450	11450	* 11200	7600	8850	5600	6800	4350		* 5000	4050	9450
			* 14950	* 14950	* 33400	24600	* 24300	16350	19050	12000	14600	9300		* 10950	8900	380
-1500	* 6550	* 6550	* 10250	* 10250	* 15250	11300	* 11300	7450	8750	5500				* 5750	4350	8970
-60	* 14650	* 14650	* 23200	* 23200	* 33000	24250	* 24400	16050	18800	11800				* 12650	9550	360
-3000	* 10650	* 10650	* 15300	* 15300	* 14050	11300	* 10550	7450	* 8100	5500				* 7000	4900	8190
-120	* 23900	* 23900	* 34650	* 34650	* 30350	24350	* 22800	16000	* 17350	11850				* 15350	10850	330
-4500			* 15700	* 15700	* 11600	11500	* 8700	7600						* 6750	6200	7000
-180			* 33700	* 33700	* 24900	24800	* 18450	16350						* 14850	13800	280

(mm) (inch)	1500 60		3000 120		4500 180		6000 240		7500 300		9000 360				(mm) (inch)			
 																		
																		
9000 360								* 14200	* 14200					* 5150	* 5150	6780		
7500 300										* 6250	* 6250			* 4700	* 4700	8040		
6000 240								* 7650	* 7650	* 12800	* 12800			* 10400	* 10400	320		
4500 180								* 16750	* 16750	* 7350	6350			* 4550	* 4550	8880		
3000 120										* 15850	13600			* 10000	* 10000	350		
1500 60														* 6200	4650	* 4550	4300	9400
0 0														* 12400	9900	* 10000	9500	370
-1500 -60														* 4950	3950	* 4700	4050	9660
-3000 -120														* 10300	8900	* 10300	8900	380
-4500 -180														* 4950	3950	* 10900	8750	9670
														* 5450	4050	* 5450	4050	9450
														* 12000	8900	* 12000	8900	380
														* 6300	4350	* 6300	4350	8970
														* 13850	9550	* 13850	9550	360
														* 7750	4900	* 7750	4900	8190
														* 17100	10850	* 17100	10850	330
														* 7550	6200	* 7550	6200	7000
														* 16550	13800	* 16550	13800	280

Identification Information

i06668974

Plate Locations and Film Locations

SMCS Code: 1000; 7000

The Product Identification Number (PIN) will be used to identify a powered machine that is designed for an operator to ride.

Caterpillar products such as engines, transmissions, and major attachments that are not designed for an operator to ride are identified by Serial Numbers.

For quick reference, record the identification numbers in the spaces that are provided below the illustration.

Product Identification Number (PIN) and CE Plate

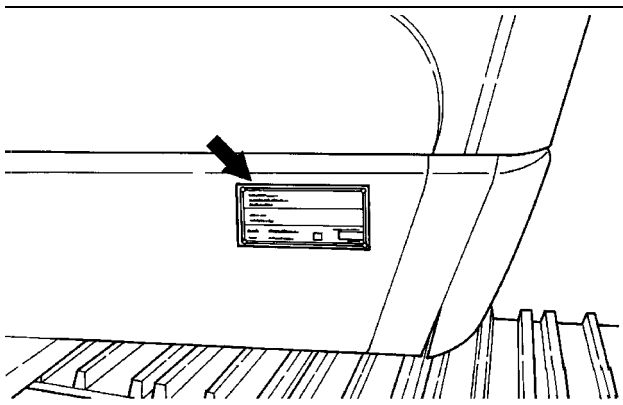

Illustration 102

g00675011

The PIN plate is positioned on the front of the machine, close to the operator compartment.

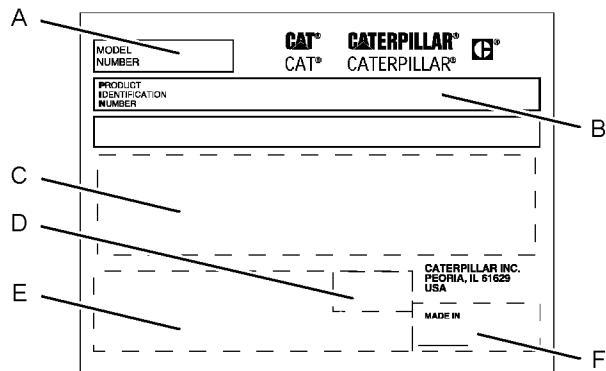

Illustration 103

g02436556

Model number (A) _____

Machine PIN (B) _____

Service Information Plate (C) _____

Year of Manufacture (If Required) (D) _____

CE Plate (If Required) (E)

Country of Origin Info Plate (If Required) (F)

Local regulation may require documentation of the Year of Manufacture in the OMM. Comply with these regulations.

Machine Specification Film

The machine specification film is on machines that are going into Japan.

The Japanese Industrial Safety and Health Act requires machine specifications to be displayed on a film that can easily be seen by the operator.

If equipped, this film will be located on the cab door.

CAT [®] 油圧ショベル			
機体質量	kg	最高 走行 速度	前進 後進 km/h
定格出力	kW		
仕様	標準仕様	労働安全衛生法による 最も不利な仕様 (含解体用機械)	
機材総質量	kg		
平均接地圧	kPa		
バケット容量	m ³		
バケット質量	kg		
最大搭載質量 (含バケット)	kg		
アタッチメント装着可能質量	kg	解体用つかみ具 鉄骨切断具 コンクリート圧砕具 ブレーカユニット	
アタッチメント装着可能質量は本体の安定度から計算された最大の質量である。 解体用つかみ具は、掘削した物の質量を含む。			
キャタピラー・ジャパン株式会社			
※は登録商標の表示です。			

Illustration 104

g03733484

Electromagnetic Emissions

Note: This label is on machines that are going into Canada.

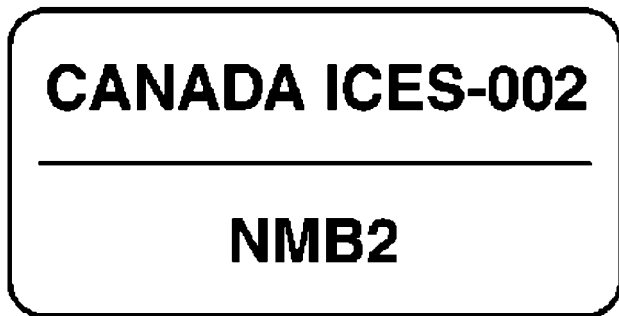

Illustration 105

g06063443

If equipped, this label is located next to the Pin plate. This label verifies that the product meets the requirements of ICES-002 Issue 6. Compliance to ICES-002 Issue 6 is accomplished by meeting electromagnetic emissions industry standard CISPR-12.

Engine Serial Number

This label is located on the engine.

Engine Serial Number _____

Sound Certification Film

If equipped, this label is located on the cab door.

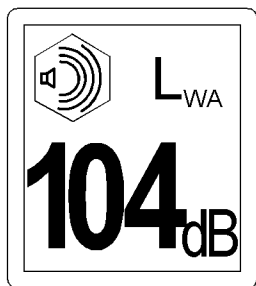

Illustration 106

g01185061

If equipped, the certification label is used to verify the environmental sound certification of the machine to the requirements of the European Union. The value that is listed on the label indicates the guaranteed exterior sound power level L_{WA} at the time of manufacture for the conditions that are specified in "2000/14/EC".

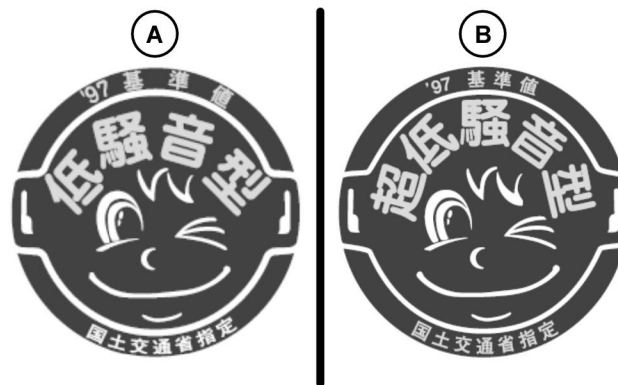

Illustration 107

g03105800

- (A) Low Noise Film
- (B) Super Low Noise Film

If equipped, these certification labels are used to verify the Japan Ministry of Land, Infrastructure, Transportation, and Tourism (MLIT) noise designation according to the Japan "Designation Rule of Low Noise Type Construction Machine".

Low Noise (A) – Verifies that the Japan "MLIT" designates the machine as a "Low Noise" type construction machine.

Super Low Noise (B) – Verifies that the Japan "MLIT" designates the machine as a "Super Low Noise" type construction machine.

i07709181

Emissions Certification Film

SMCS Code: 1000; 7000; 7405

Note: This information is pertinent in the United States, in Canada and in Europe.

Consult your Cat dealer for an Emission Control Warranty Statement.

This label is located on the engine.

Declaration of Conformity

SMCS Code: 1000; 7000

Table 17

An EC or EU Declaration of Conformity document was provided with the machine if it was manufactured to comply with specific requirements for the European Union. In order to determine the details of the applicable Directives, review the complete EC or EU Declaration of Conformity provided with the machine. The extract shown below from an EC or EU Declaration of Conformity for machines that are declared compliant to "2006/42/EC" applies only to those machines originally "CE" marked by the manufacturer listed and which have not since been modified.

Original EC or EU DECLARATION OF CONFORMITY

Manufacturer: Caterpillar Inc., 100 N.E. Adams Street, Peoria, Illinois 61629, USA

Person authorized to compile the Technical File and to communicate relevant part (s) of the Technical File to the Authorities of European Union Member States on request:

Standards & Regulations Manager, Caterpillar France SAS
40 Avenue Leon-Blum 38000 Grenoble, France

I, the undersigned, _____, hereby certify that the construction equipment specified hereunder

Description:	Generic Denomination:	Earth-moving Equipment
	Function:	Hydraulic Excavator
	Model/Type:	335F L
	Serial Number:	
	Commercial Name:	Caterpillar

Fulfills all the relevant provisions of the following Directives

Directives	Notified Body	Document No.
2000/14/EC amended by 2005/88/EC, Note (1)		
2006/42/EC	N/A	
2004/108/EC	N/A	
2014/30/EU	N/A	

Note (1) Annex - _____ Guaranteed Sound Power Level - _____ dB (A)
 Representative Equipment Type Sound Power Level - _____ dB (A)
 [Engine Power per _____ - _____ kW Rated engine speed - _____ rpm
 Technical Documentation accessible through person listed above authorized to compile the Technical File

Done at:

Signature

Date:

Name/Position

Note: The above information was correct as of March 2016, but may be subject to change, please refer to the individual declaration of conformity issued with the machine for exact details.

Operation Section

Before Operation

i07786730

Mounting and Dismounting

SMCS Code: 6700; 7000

Illustration 108

g00037860

Typical example

Mount the machine and dismount the machine only at locations that have steps and/or handholds. Before you mount the machine, clean the steps and the handholds. Inspect the steps and handholds. Make all necessary repairs.

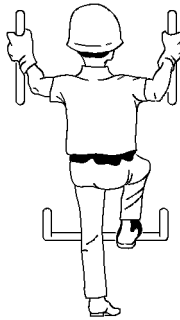
Face the machine whenever you get on or off the machine.

Maintain a three-point contact with the steps and with the handholds.

Note: Three-point contact can be two feet and one hand. Three-point contact can also be one foot and two hands.

Do not mount a moving machine. Do not dismount a moving machine. Never jump off the machine. Do not carry tools or supplies when you try to mount the machine or when you try to dismount the machine. Use a hand line to pull equipment onto the platform. Do not use any controls as handholds when you enter the operator compartment or when you exit the operator compartment.

Machine Access System Specifications

The machine access system has been designed to meet the intent of the technical requirements in "ISO 2867:2011 Earth-moving Machinery – Access Systems". The access system provides for operator access to the operator station and to conduct the maintenance procedures described in Maintenance section.

Alternate Exit

Machines that are equipped with cabs have alternate exits. For additional information, see Operation and Maintenance Manual, "Alternate Exit".

i02706111

Daily Inspection

SMCS Code: 1000; 6319; 6700; 7000

NOTICE

Accumulated grease and oil on an engine is a fire hazard.

Remove this debris with steam cleaning or high pressure water each time any significant quantity of oil (or other fluid) is spilled on or near the engine.

Wipe clean all fittings, caps and plugs before servicing.

For maximum service life of the machine, perform a thorough daily inspection before you mount the machine and before you start the engine.

Perform the following procedures on a daily basis.

- Operation and Maintenance Manual, "Boom and Stick Linkage - Lubricate"
- Operation and Maintenance Manual, "Bucket Linkage - Lubricate"
- Operation and Maintenance Manual, "Cooling System Level - Check"
- Operation and Maintenance Manual, "Engine Oil Level - Check"
- Operation and Maintenance Manual, "Fuel System Water Separator - Drain"
- Operation and Maintenance Manual, "Fuel Tank Water and Sediment - Drain"
- Operation and Maintenance Manual, "Hydraulic System Oil Level - Check"
- Operation and Maintenance Manual, "Indicators and Gauges - Test"

Operation Section
Daily Inspection

- Operation and Maintenance Manual, “Quick Coupler - Lubricate”
- Operation and Maintenance Manual, “Seat Belt - Inspect”
- Operation and Maintenance Manual, “Track Adjustment - Inspect”
- Operation and Maintenance Manual, “Track Adjustment - Adjust”
- Operation and Maintenance Manual, “Travel Alarm - Test”
- Operation and Maintenance Manual, “Undercarriage - Check”

Refer to the Maintenance Section for the detailed procedures. Refer to the Maintenance Interval Schedule for a complete list of scheduled maintenance.

Note: Watch closely for leaks. If you observe a leak, find the source of the leak and correct the leak. If you suspect a leak or you observe a leak, check the fluid levels more frequently.

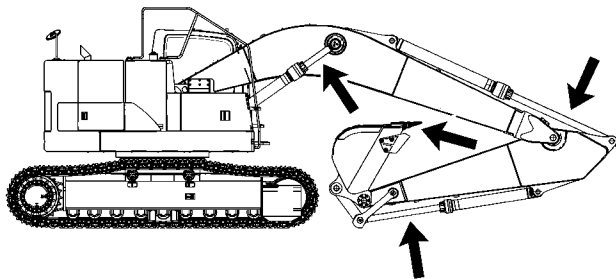

Illustration 109

g01357291

Inspect the attachment control linkage, attachment cylinders, and attachment for damage or excessive wear. Make any necessary repairs.

Inspect the lights for broken bulbs and for broken lenses. Replace any broken bulbs and any broken lenses.

Inspect the engine compartment for any trash buildup. Remove any trash buildup from the engine compartment.

Inspect the cooling system for any leaks, for faulty hoses and for any trash buildup. Correct any leaks. Remove any trash from the radiator.

Inspect all of the belts for the engine attachments. Replace any belts that are worn, frayed, or broken.

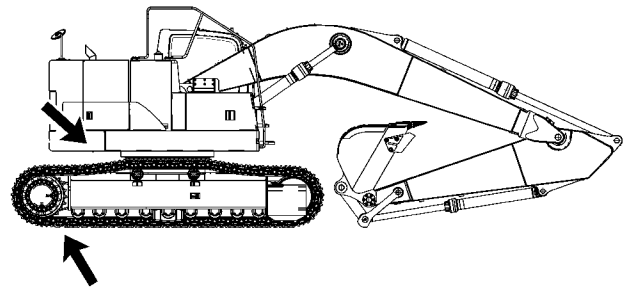

Illustration 110

g01357292

Inspect the hydraulic system for leaks. Inspect the tank, cylinder rod seals, hoses, tubes, plugs, connections, and fittings. Correct any leaks in the hydraulic system.

Inspect the final drives for leaks. Make any necessary repairs.

Inspect the swing drive for leaks.

Make sure that all covers and guards are securely attached. Inspect the covers and the guards for damage.

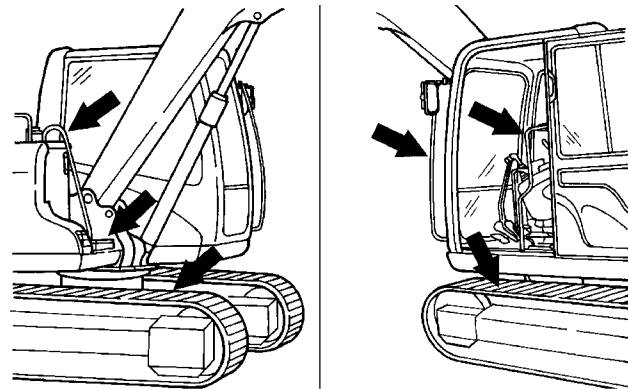

Illustration 111

g00732408

Inspect the steps, the walkways, and the handholds. Clean the steps, the walkways, and the handholds. Make any necessary repairs.

Inspect the operator compartment for trash buildup. Check for trash buildup under the floorplate and on the crankcase guard. Keep these areas clean.

Adjust the mirrors in order to achieve the best visibility.

Machine Operation

i06244619

Alternate Exit

SMCS Code: 7310

Front Window (If Equipped)

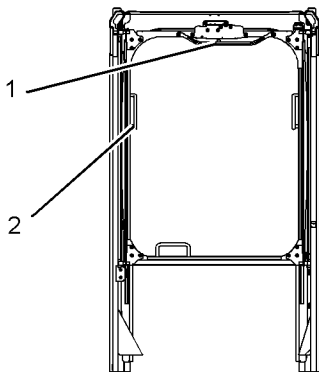

Illustration 112

g02050493

- (1) Lever
- (2) Handle

The front window serves as an alternate exit.

In order to remove the front window, move lever (1) to the right. Grab handles (2) and lift the window into the overhead storage position. Exit through the front window.

Right Side Window

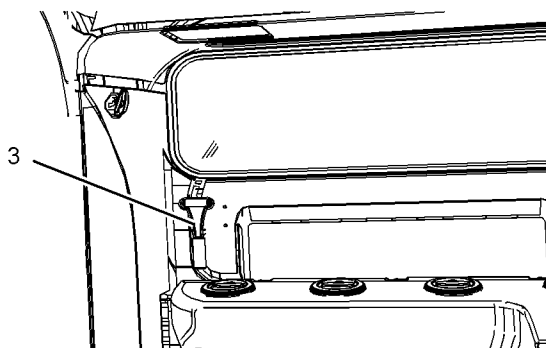

Illustration 113

g02050942

- (3) Hammer (If Equipped)



Alternate Exit – The right side window serves as an alternate exit.



Break Glass – Perform the following procedure in order to exit through the right side window. Hammer (3) is mounted near the rear window of the cab. Strike the right side window with the hammer in order to break the glass. Climb through the opening of the right side window in order to exit the cab.

Roof Hatch (If Equipped)

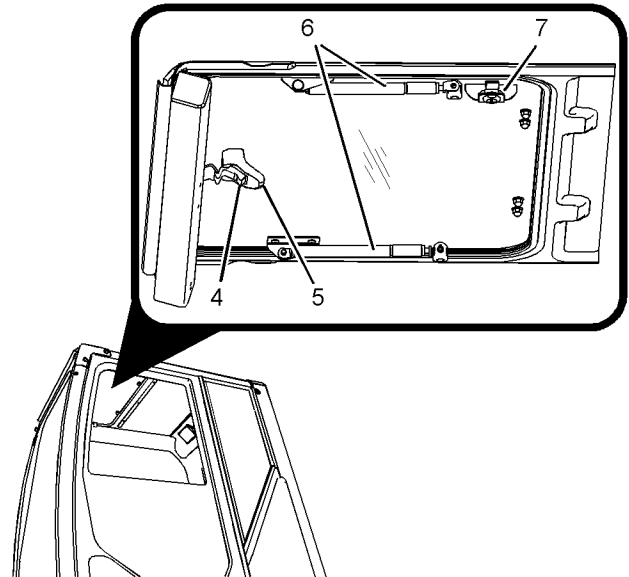

Illustration 114

g02851621

- (4) Latch
- (5) Grip
- (6) Gas springs
- (7) Lock mechanism

Note: Before operating the machine, make sure lock mechanism (7) (if equipped) is unlocked.



Alternate Exit – The roof hatch serves as an alternate exit.

Slide the visor cover back. If equipped, make sure lock mechanism (7) is unlocked.

Release latch (4). Hold grip (5) and push the roof hatch outward.

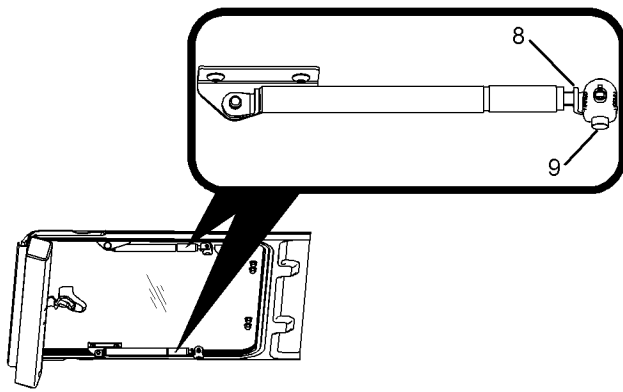

Illustration 115

g02901996

If equipped with gas springs (6), press gas spring release (9) and remove gas spring shaft (8) in order to open hatch wider.

Exit through the roof hatch.

Removing the Roof Hatch from the Outside

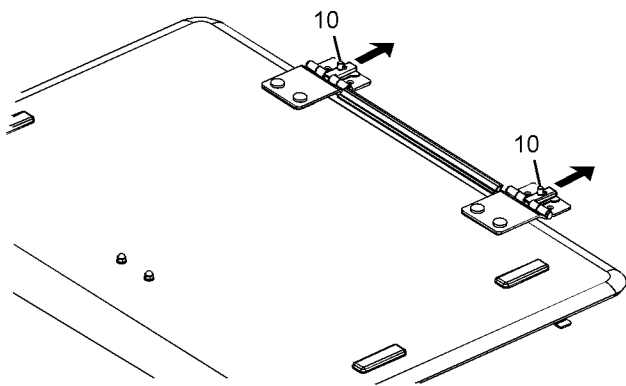

Illustration 116

g02851583

(10) Hinge pin release

If equipped with hinge pin release (10), the roof hatch can also be removed from the outside of the cab.

Press hinge pin release (10) and slide backward. The hinge pin should detach and allow the hatch to be lifted. Exit through the roof hatch.

Note: Lock mechanism (7) (if equipped) must be unlocked in order to allow the hatch to be lifted.

Roof Hatch (If Equipped)

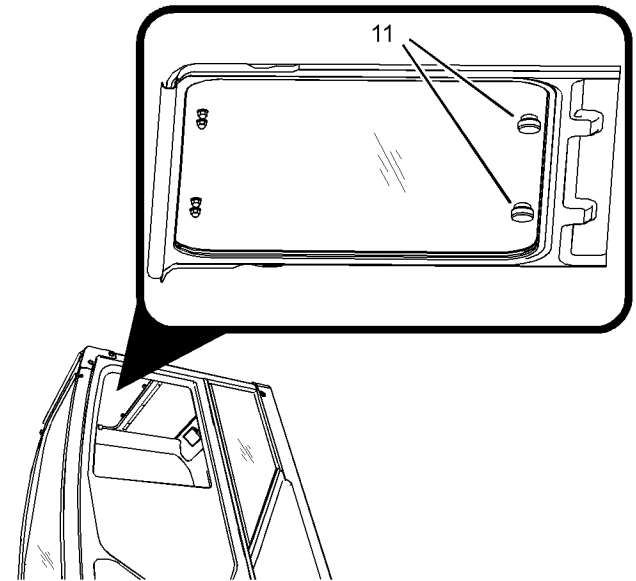

Illustration 117

g02851579



Alternate Exit – The roof hatch serves as an alternate exit.

Slide the visor cover back.

Remove knobs (11) and push the roof hatch outward. Exit through the roof hatch.

Note: Do not open the hatch during general operation in order to maintain the functionality of the alternate exit.

FOGS (If Equipped)

Note: Some FOGS are fixed/bolted-on and others can be opened. This information pertains to FOGS that can be opened.

Top FOGS

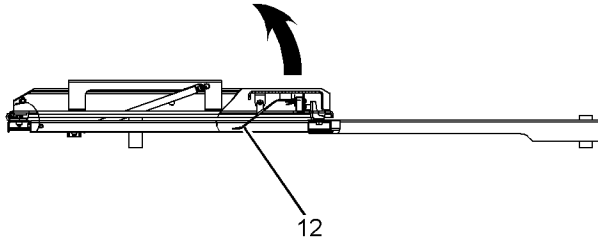

Illustration 118

g02902217

In order to exit through the roof hatch, the FOGS guard is equipped with a release latch. Open the roof hatch as stated above. As the roof hatch is being pushed outward, the roof hatch will hit lever (12). Lever (12) will allow the FOGS to lift upward. Exit through the roof hatch.

In order to open the top FOGS from the outside of the machine, reach under the FOGS and pull up on release lever (12). Follow the directions for removing the hatch from the outside.

Front FOGS

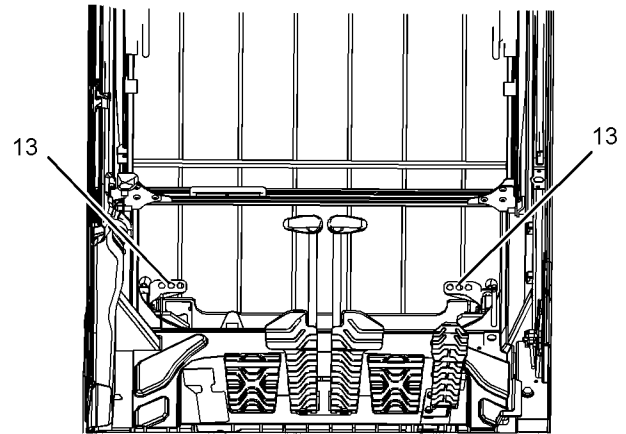

Illustration 119

g02902219

In order to exit through the front window, the FOGS guard is equipped with a release latch. Open the front window as stated above and remove the lower window. Press down on levers (13) in order to open the front FOGS. Exit through the front window.

i07186721

Seat

SMCS Code: 5258-025; 7312-025; 7324; 7327

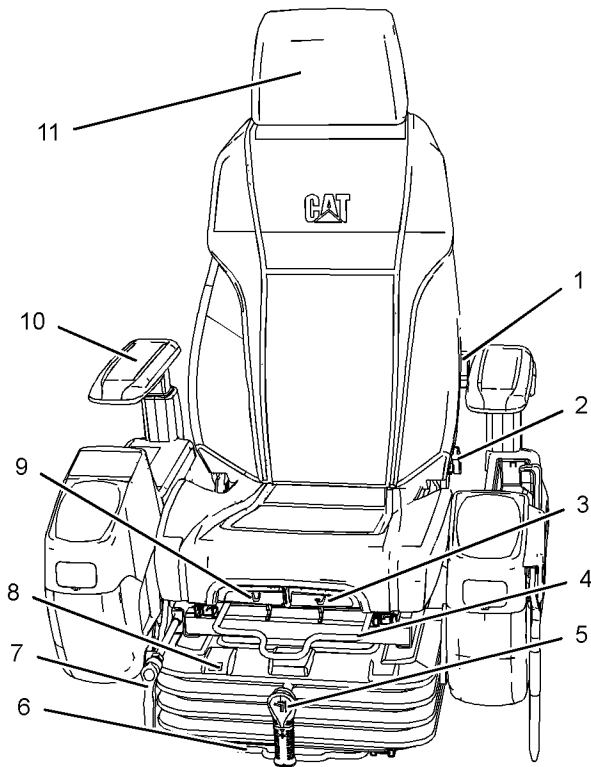

Illustration 120

g01636841

- (1) Adjustment lever for the lumbar support
- (2) Adjustment lever for reclining the seat
- (3) Lever for the seat cushion adjustment
- (4) Seat fore and aft adjustment.
- (5) Seat height adjustment (if equipped)
- (6) Fore and aft seat and console adjustment
- (7) Console adjustment
- (8) Indicator
- (9) Seat angle lever
- (10) Armrest
- (11) Headrest

The lumbar support is located in the back of the seat. Turn knob (1) (if equipped) counterclockwise to increase the force of the lumbar support. To decrease the lumbar support, continue to turn the knob counterclockwise.

Pull up lever (2) to change the angle of the seat. Hold the seat back in the desired position. Release the lever.

Push in lever (3) to adjust the length of the cushion.

To adjust the seat forward or backward, pull up lever (4) and hold the lever. Move the seat to the desired position. To lock the seat in the selected position, release the lever.

Note: Before adjusting the seat forward or backward, make sure that the lever for the seat height adjustment (5) is in the downward position.

Turn lever (5) to adjust the seat and the console to the desired height. To raise the seat height, pull the grip downward and rotate the grip with the plus sign outward. To lower the seat height, pull the grip downward and rotate the grip with the minus sign outward. Release grip to return to the original position.

Pull lever (6) to adjust the seat and the console forward and backward.

Use handle (7) to adjust the height of the console. When the lever is pulled forward, a gear is released. The operator can rotate the lever freely. Release the lever to return to the original position.

Push the lever (9) to adjust the tilt angle of the seat.

The operator can adjust the height of headrest (11). To adjust the headrest, hold the headrest with both hands. Move the headrest up and down. Release the headrest when the desired position is attained. The headrest will remain in the desired position.

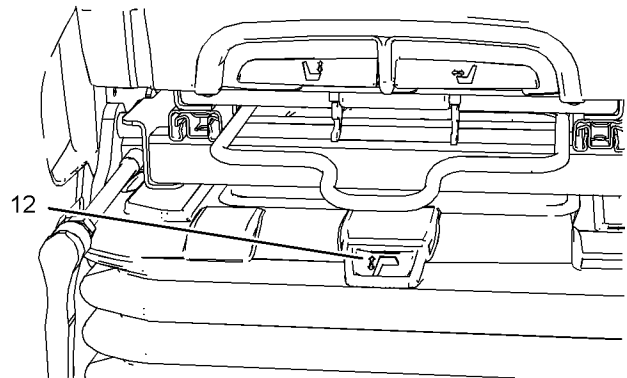

Illustration 121

g01637296

If your machine is equipped with an air ride suspension, the seat will be equipped with a lever (12). Pull up the lever to raise the height of the seat. Push down on the lever to lower the seat. If the adjustment is correct, indicator (8) will turn green. If the indicator shows red, further adjustment is required.

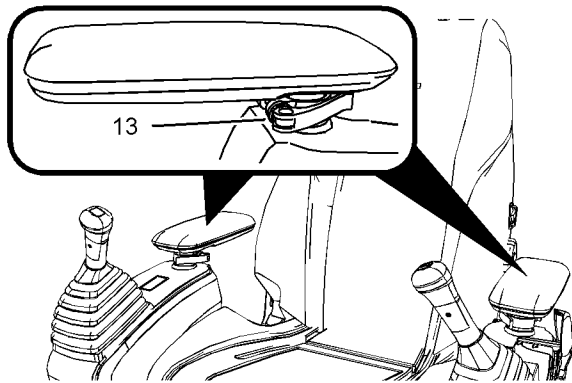

Illustration 122

g02697124

(13) Armrest height adjustment

The height of the armrest can be adjusted. Unlatch lever (13) to adjust the height of the armrest. Move the armrest upward or move the armrest downward. Latch the lever when the armrest is in the desired position.

Heated Seat and Ventilated Seat (If Equipped)

WARNING

Heat-induced burns can occur when some people use a seat heater. Do not use the seat heater if you have a reduced ability to sense temperature changes, a reduced ability to feel pain, or have sensitive skin.

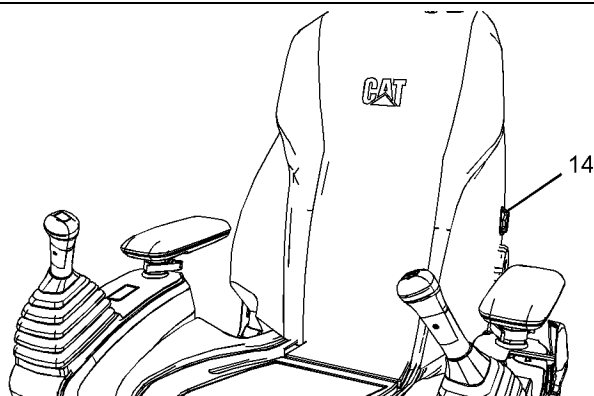

Illustration 123

g02697116

Heated Seat Switch – If equipped with a heated seat, press the top of rocker switch (14) to turn the seat heater to the ON position. Press the bottom of rocker switch (14) to turn the seat heater to the OFF position.

Heated and Ventilated Seat Switch – If equipped with a heated and ventilated seat, press the top of rocker switch (14) for heat. Press the bottom of

rocker switch (14) for ventilation. The center switch position is OFF.

i04200349

Seat Belt

SMCS Code: 7327

Note: This machine was equipped with a seat belt when the machine was shipped from Caterpillar. At the time of installation, the seat belt and the instructions for installation of the seat belt meet the SAE J386 and ISO 6683 standards. Consult your Cat dealer for all replacement parts.

Always check the condition of the seat belt and the condition of the mounting hardware before you operate the machine.

Seat Belt Adjustment for Non-Retractable Seat Belts

Adjust both ends of the seat belt. The seat belt should be snug but comfortable.

Lengthening the Seat Belt

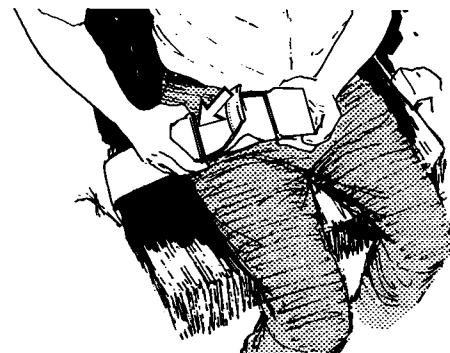

Illustration 124

g00100709

1. Unfasten the seat belt.

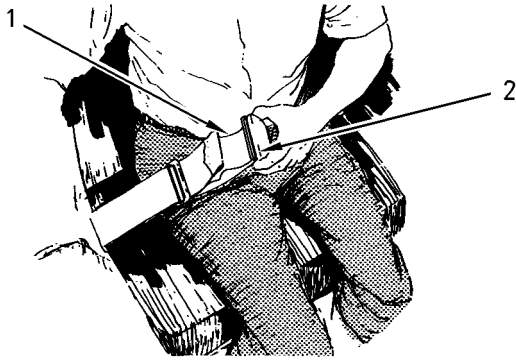

Illustration 125

g00932817

2. To remove the slack in outer loop (1), rotate buckle (2). This will free the lock bar. This permits the seat belt to move through the buckle.
3. Remove the slack from the outer belt loop by pulling on the buckle.
4. Loosen the other half of the seat belt in the same manner. If the seat belt does not fit snugly with the buckle in the center, readjust the seat belt.

Shortening the Seat Belt

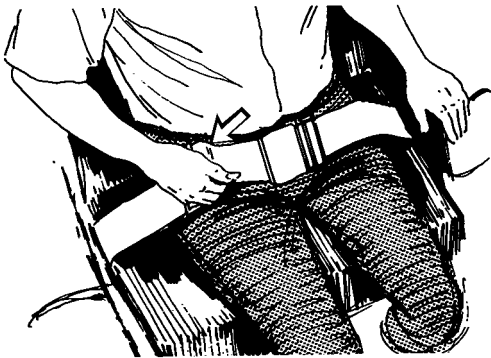

Illustration 126

g00100713

1. Fasten the seat belt. Pull out on the outer belt loop in order to tighten the seat belt.
2. Adjust the other half of the seat belt in the same manner.
3. If the seat belt does not fit snugly with the buckle in the center, readjust the seat belt.

Fastening The Seat Belt

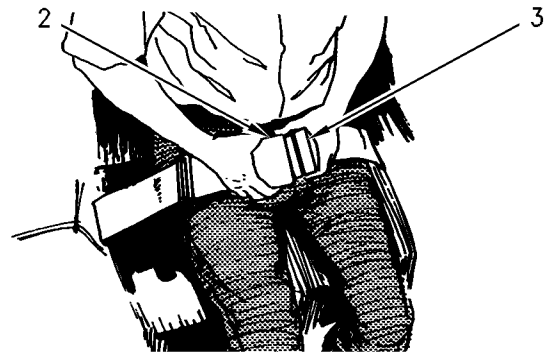

Illustration 127

g00932818

Fasten the seat belt catch (3) into the buckle (2). Make sure that the seat belt is placed low across the lap of the operator.

Releasing The Seat Belt

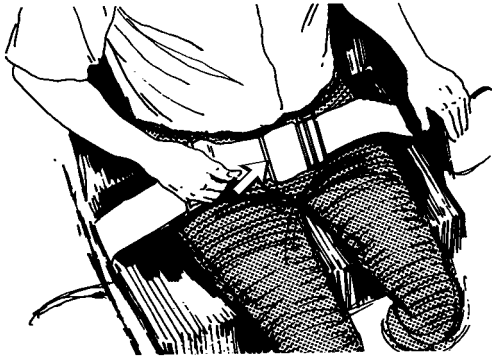

Illustration 128

g00100717

Pull up on the release lever. This will release the seat belt.

Seat Belt Adjustment for Retractable Seat Belts

Fastening The Seat Belt

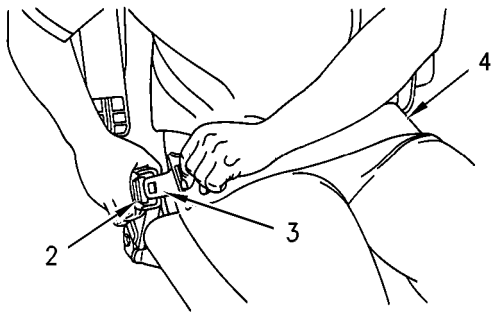

Illustration 129

g00867598

Pull seat belt (4) out of the retractor in a continuous motion.

Fasten seat belt catch (3) into buckle (2). Make sure that the seat belt is placed low across the lap of the operator.

The retractor will adjust the belt length and the retractor will lock in place. The comfort ride sleeve will allow the operator to have limited movement.

Releasing The Seat Belt

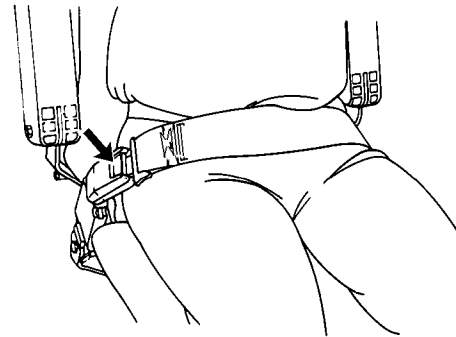

Illustration 130

g00039113

Push the release button on the buckle in order to release the seat belt. The seat belt will automatically retract into the retractor.

Extension of the Seat Belt

⚠ WARNING

When using retractable seat belts, do not use seat belt extensions, or personal injury or death can result.

The retractor system may or may not lock up depending on the length of the extension and the size of the person. If the retractor does not lock up, the seat belt will not retain the person.

Longer, non-retractable seat belts and extensions for the non-retractable seat belts are available.

Caterpillar requires only non-retractable seat belts to be used with a seat belt extension.

Consult your Cat dealer for longer seat belts and for information on extending the seat belts.

i06299970

Selective Catalytic Reduction Warning System

SMCS Code: 1091-WXX; 7400

The selective catalytic reduction (SCR) system is a system used to reduce NOx emissions from the engine. Diesel exhaust fluid (DEF) is pumped from the DEF tank and is sprayed into the exhaust stream. The DEF reacts with the SCR catalyst to reduce NOx and leaves a nitrogen and water vapor. The Exhaust Gas Recirculation (EGR) system cools, measures, and introduces recalculated exhaust gas into the intake manifold to aid in NOx reduction.

NOTICE

Stopping the engine immediately after the engine has been working under load can result in overheating of SCR components.

Refer to the Operation and Maintenance Manual, "Engine Stopping" procedure to allow the engine to cool and to prevent excessive temperatures in the turbocharger housing and the DEF injector.

Note: With the operator key in the OFF position, the purge system will activate.

Definitions

Observe the following definitions.

Self-correct – Fault condition no longer exists. An active fault code will no longer be active.

Notification – Action taken by the system to alert the operator of pending Inducement.

Inducement – Engine derates, vehicle speed limits, or other actions intended to prompt the operator to repair or maintain the emission control system.

Inducement Trigger – Fault conditions that result in activation of the inducement strategy. DEF level inducement faults have a diagnostic fault code. DEF quality fault, SCR tampering fault, SCR system fault, and EGR system faults will all have a related diagnostic fault code along with an inducement diagnostic fault code.

First occurrence – A DEF quality fault, SCR tampering fault, SCR system fault, or an EGR system fault becomes active for the first time.

Repeat occurrence – If any DEF quality fault, SCR tampering fault, SCR system fault, or an EGR system fault becomes active again within 40 hours of the first occurrence.

Safe Harbor Mode – Safe harbor mode is a 20 minute engine run time period. The engine can be operated with full power after reaching a level 3 inducement. Once in level 3 inducement, the operator can perform a key cycle and the engine will enter safe harbor mode. Safe harbor mode can only be implemented once. Safe harbor mode is not allowed for DEF level inducements.

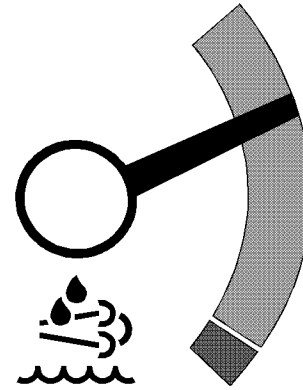

Illustration 131

g03684888

DEF Level Normal

Inducement Strategy for DEF Level

If multiple warnings are present in the system, the most important problem is shown first. Press the right key or press the left key in order to view all of the warnings that are present in the machine. If no keys are pressed within 5 seconds, the display will return to the most important problem.

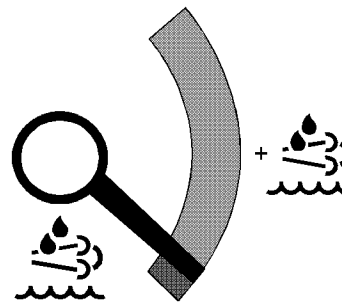

Illustration 132

g03681105

DEF Level Low

If the DEF level falls below 20%, "DEF Level Low" message will be displayed on the monitor. To avoid further inducements, turn the key to the OFF position and add DEF to the DEF tank.

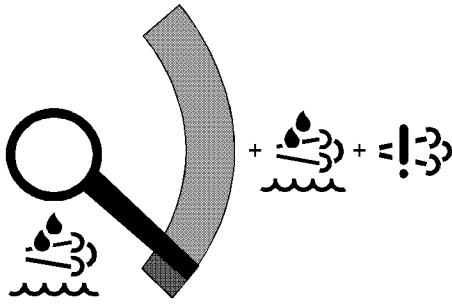

Illustration 133 g03681073
 DEF Level Low and Emission Fault

If the DEF level falls below 13.5%, a level 1 inducement event will occur. a “DEF Level Low” message and an “Emission Fault” message will appear on the monitor.

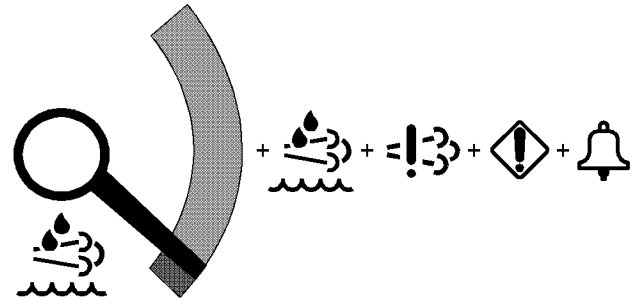

Illustration 135 g03681078
 DEF Level Low, Emission Fault, Flashing Action Lamp, and Audible Alarm

If the ECM is configured to “Reduced Performance” and the DEF tank has been emptied of all DEF, the engine will be in a level 3 final inducement. If the ECM is configured to “Reduced Time” and the DEF level is 3%, the engine will be in a level 3 final inducement. Prior to final inducement a “DEF Level Low” message, and an “Emission Fault” message will appear on the monitor. The action lamp on the monitor will flash and an audible alarm will sound 20 seconds prior to the final inducement. The engine will be taken to low idle or will be shut down. Once shut down, the engine can be restarted for 5 minute periods at reduced speed and torque. If set to idle, the engine will idle indefinitely at reduced torque. The amber indicator next to the DEF level gauge on the dash will remain lit.

Note: Turn the key to the OFF position and add DEF to the DEF tank to reset the DEF level inducement.

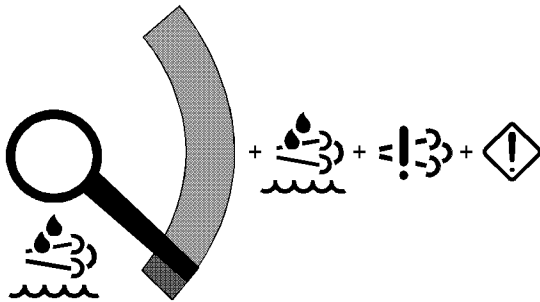

Illustration 134 g03681077
 DEF Level Low, Emission Fault, and Flashing Action Lamp

If the DEF level is below 7.5%, a level 2 inducement event will occur. a “DEF Level Low” message and an “Emission Fault” message will appear on the monitor. The action lamp on the monitor will flash. If the ECM is configured to “Reduced Performance” and the DEF level has reached 1%, the machine will be limited to 75% torque.

Inducement Strategy for DEF Quality, Tampering, SCR System Fault, and Impeded EGR

If multiple warnings are present in the system, the most important problem is shown first. Press the right key or press the left key in order to view all of the warnings that are present in the machine. If no keys are pressed within 5 seconds, the display will return to the most important problem.

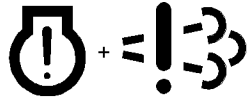

Illustration 136

g03623190

A “Engine Fault Check Engine” message and an “Emission Fault” message will appear on the monitor for a fault resulting from poor DEF quality, SCR system tampering, SCR system fault, or an EGR system fault. If the fault is the result of poor DEF quality, SCR system tampering, or SCR system fault, a first occurrence will result in a level 1 inducement for a duration of 2.5 hours. The level 1 inducement will also illuminate the check engine lamp. Repeat occurrences will result in a level 1 inducement duration of 5 minutes. If the fault is the result of an EGR system fault, a first occurrence will result in a level 1 inducement for a duration of 35 hours. Repeat occurrences will result in a level 1 inducement duration of 48 minutes.

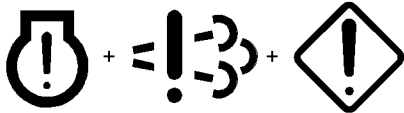

Illustration 137

g03623191

If a fault condition exists for the entire duration of inducement level 1, the strategy advances to inducement level 2. A “Engine Fault Check Engine” message, and an “Emission Fault” message will appear on the monitor and the action lamp on the monitor will flash for a fault resulting from poor DEF quality, SCR system tampering, SCR system fault, or an EGR system fault. For poor DEF quality, SCR system tampering, and SCR system faults, the duration for a level 2 inducement is 70 minutes for the first occurrence. For EGR system faults, the duration for a level 2 inducement is 60 minutes for the first occurrence. Repeat occurrences for poor DEF quality, SCR system tampering, and SCR system faults will result in a level 2 inducement of 5 minutes. Repeat occurrences for EGR system faults will result in a level 2 inducement of 60 minutes.

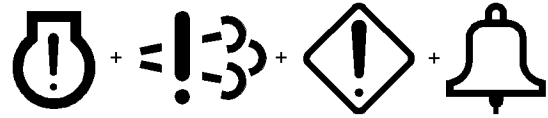

Illustration 138

g03623193

If a fault condition exists for the entire duration of inducement level 2, the strategy advances to inducement level 3. A “Engine Fault Check Engine” message, and an “Emission Fault” message will appear on the monitor, the action lamp will flash, and an audible alarm will sound 20 seconds prior to the level 3 inducement. The engine will be taken to low idle or will be shut down. After the level 3 inducement you may cycle the key, which will allow 20 minutes of engine run time with full torque. After 20 minutes, the engine will be in level 3 final inducement and will allow idle only or be shut down until the issue has been resolved. Once shut down, the engine can be restarted for 5 minute periods at reduced speed and torque. If set to idle, the engine will idle indefinitely at reduced torque.

Note: Contact your Cat dealer for repairs if a fault occurs.

i07232284

Operator Controls

SMCS Code: 7300; 7301; 7451

Note: Your machine may not be equipped with all the controls that are described in this topic.

Cat Grade Control (If Equipped)

Cat Grade Control is designed to calculate bucket tip position and provide visual and audible feedback to the operator. This feedback allows the operator to achieve the desired grade safer, quicker and more accurately than traditional grading techniques.

For information on how to use Cat Grade Control, refer to Operation and Maintenance Manual, M0077726, "Cat Grade Control for 2D and 3D Excavators".

Operator Controls

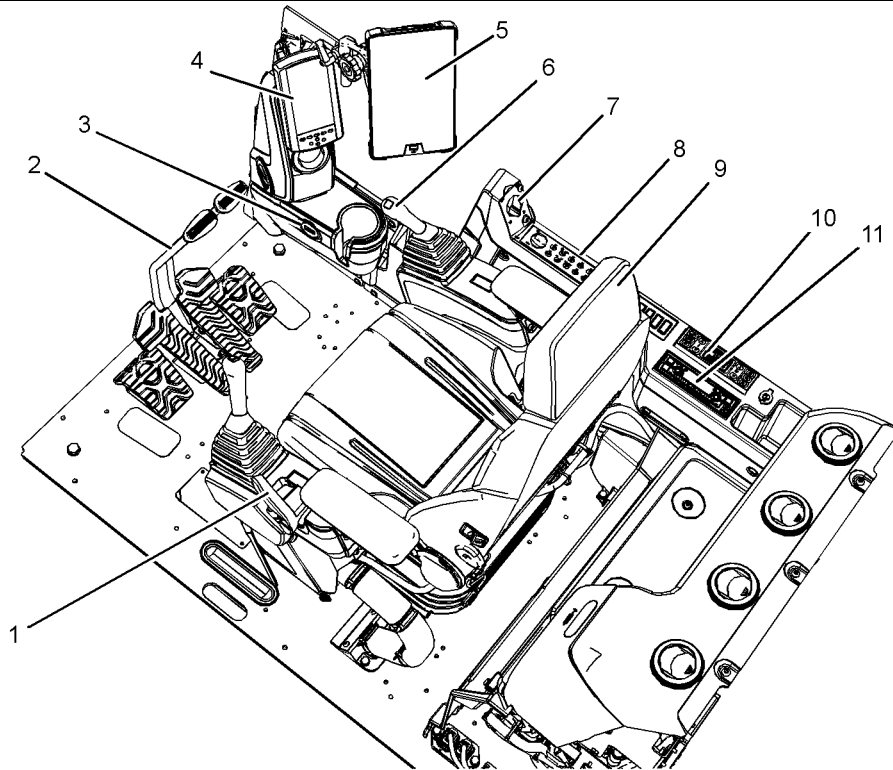

Illustration 139

g06169881

(1) Hydraulic lockout control
(2) Travel controls
(3) Service hour meter
(4) Monitor

(5) Cat Grade Control monitor
(6) Joystick controls
(7) Engine start switch
(8) Right side control panel

(9) Operator seat
(10) Air conditioning and heating control
(11) Radio

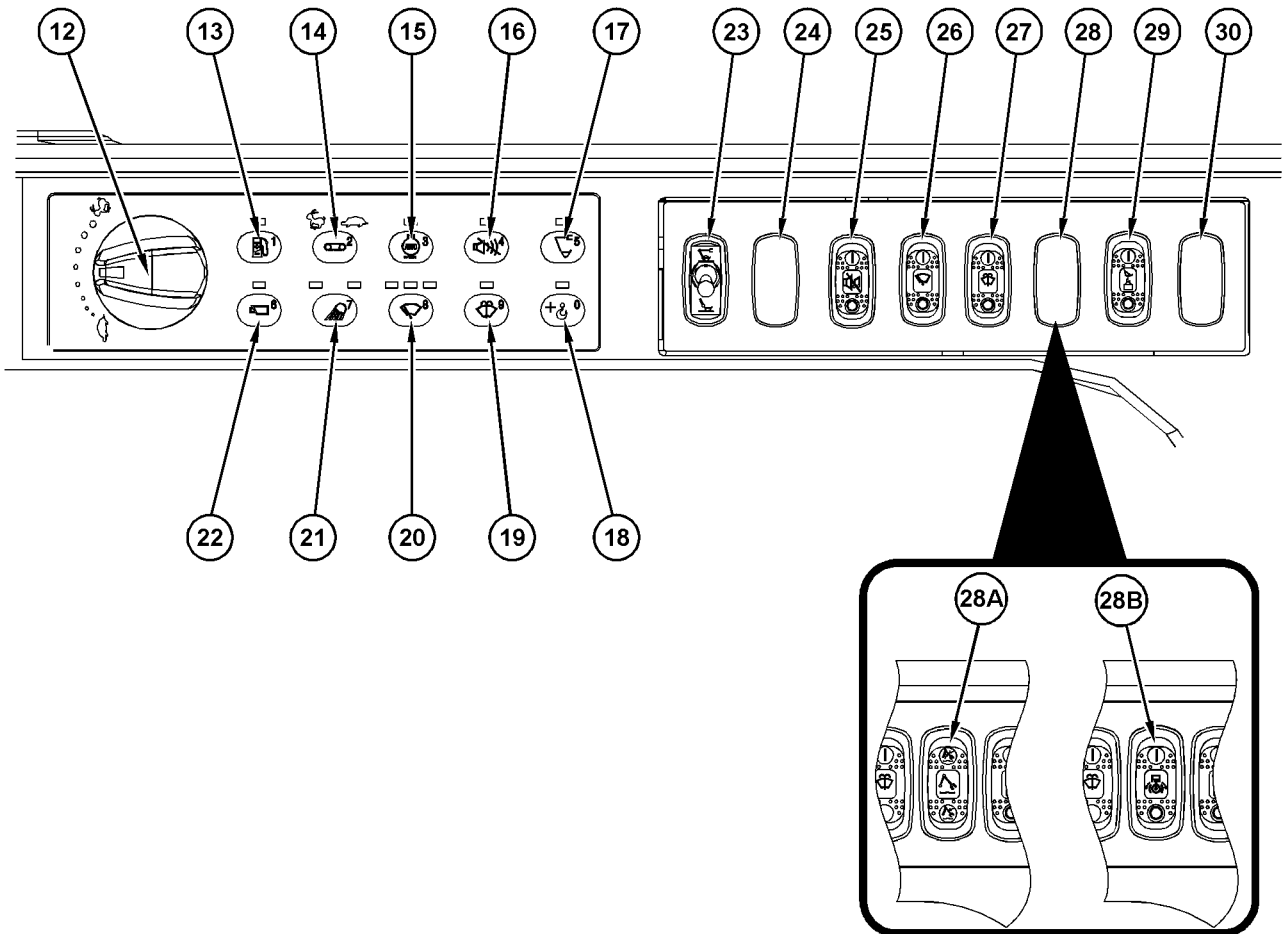

Illustration 140

g06170452

- | | | |
|---|----------------------------|------------------------------|
| (12) Engine speed control | (19) Window washer | (26) Lower window wiper |
| (13) Power mode | (20) Window wiper | (27) Lower window washer |
| (14) Travel speed control | (21) Light switch | (28A) SmartBoom control |
| (15) Automatic engine speed control (AEC) | (22) Rear/Side view camera | (28B) Fine swing control |
| (16) Travel alarm switch | (23) Quick coupler control | (29) Overload warning device |
| (17) Work tool control | (24) Empty | (30) Empty |
| (18) Heavy lift control | (25) Radio mute | |

Note: Not all switches present in the cab will be functional. If an attachment was not ordered, a switch may still be present but not functional.

Hydraulic Lockout Control (1)

The lever for the hydraulic lockout control is located at the left side of the left console.



Locked – Move the travel levers/pedals and move the joysticks to the HOLD (center) position. Move the lever for the hydraulic lockout control backward to the LOCKED position. All the factory installed hydraulic controls will become inoperable.

Note: Make sure that the lever for the hydraulic lockout control is in the LOCKED position before attempting to start the engine. If the lever is in the UNLOCKED position, the engine start switch will not function.



Unlocked – Move the lever for the hydraulic lockout control forward to the UNLOCKED position. All the factory installed hydraulic controls will become operable.

Travel Control (2)

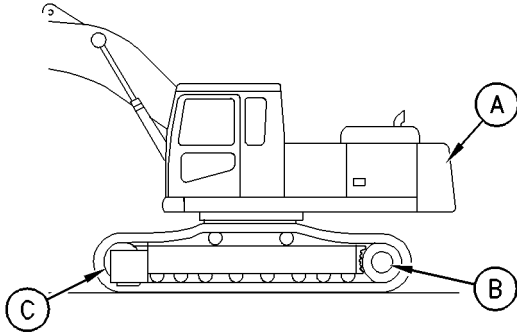

Illustration 141 g00753277

Position for normal travel

- (A) Rear of machine
- (B) Final drive
- (C) Idler

When you travel, make sure that final drive sprockets (B) are under the rear of the machine.

Stop – Release the travel levers/pedals to stop the machine. When you release the travel levers/pedals from any position, the travel levers/pedals will return to the CENTER position. The travel brakes will be applied.

Move both of the travel levers or both of the travel pedals equally in the same direction to travel straight.

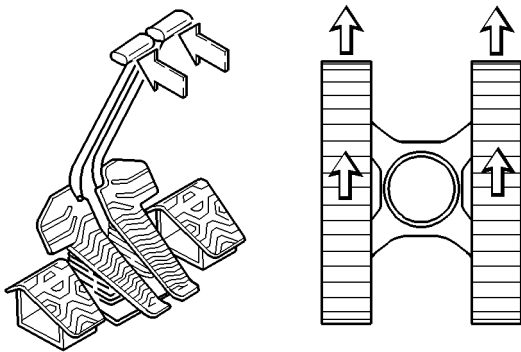

Illustration 142 g00731542

FORWARD travel

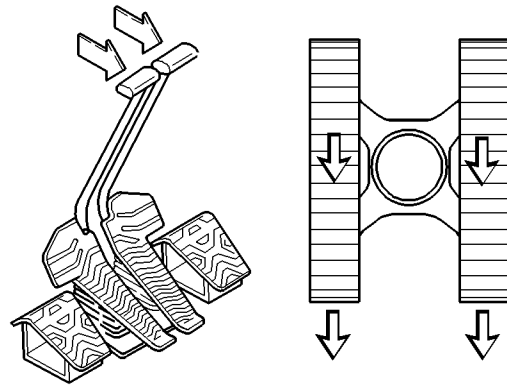

Illustration 143
REVERSE travel

g00731543

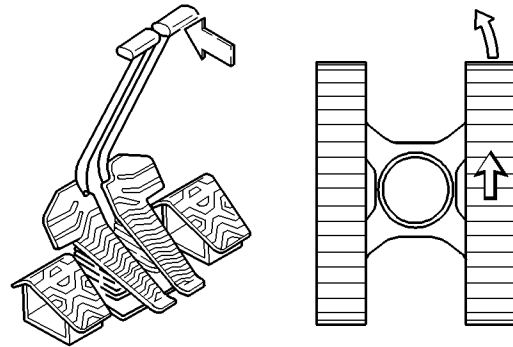

Illustration 144
Pivot left turn (FORWARD)

g00731472

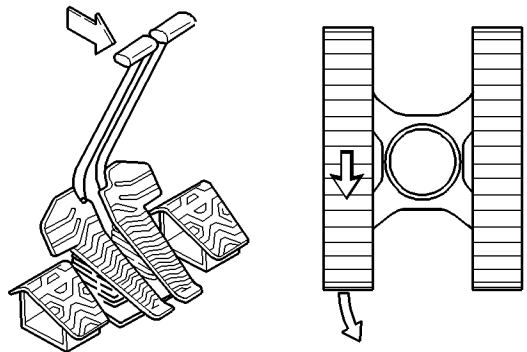

Illustration 145
Pivot Left Turn (REVERSE)

g00731478

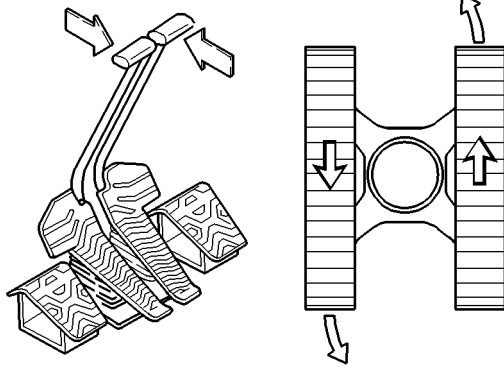

Illustration 146

g00731476

Counterrotate turn (LEFT)

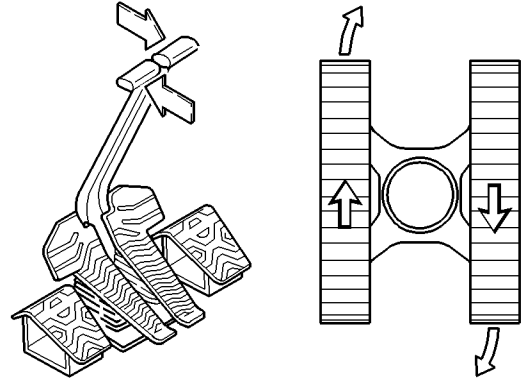

Illustration 149

g00731477

Counterrotate turn (RIGHT)

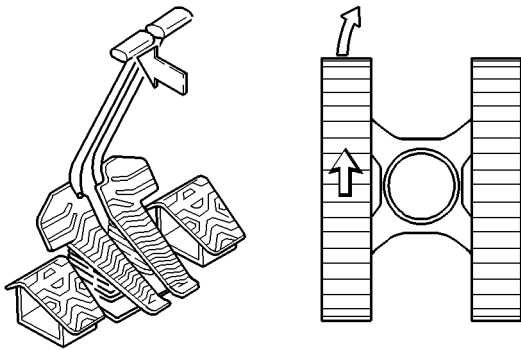

Illustration 147

g00731471

Pivot right turn (FORWARD)

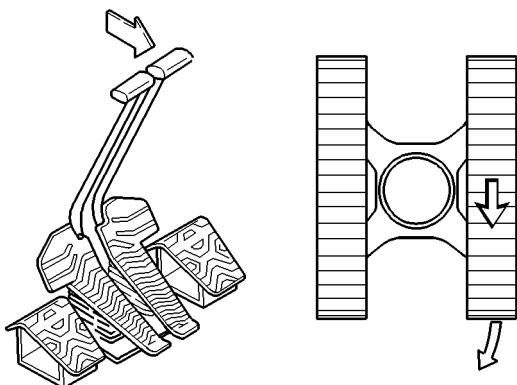

Illustration 148

g00731479

Pivot right turn (REVERSE)

Service Hour Meter (3)



Service Hour Meter – This display indicates the total operating hours of the engine. Use the display to determine the service hour maintenance intervals.

Monitor (4)

The monitor is used to display various operating information of the machine. For more information on the operation of the monitor, refer to Operation and Maintenance Manual, "Monitoring System".

Cat Grade Control Monitor (5) (if equipped)

The monitor is used to display Cat Grade Control operating information. For more information on the operation of the monitor, refer to Operation and Maintenance Manual, M0077726, "Cat Grade Control for 2D and 3D Excavators".

Joystick Controls (6)

The joystick control is used to control certain functions of the machine and work tools. For more information on the individual functions of the joysticks, refer to Operation and Maintenance Manual, "Joystick Controls".

Note: During a boom down function the machine ECM may reduce engine speed. The reduced engine speed improves the overall fuel consumption.

Engine Start Switch (7)

NOTICE

The engine start switch must be in the ON position and the engine must be running in order to maintain electrical functions and hydraulic functions. This procedure must be followed in order to prevent serious machine damage.

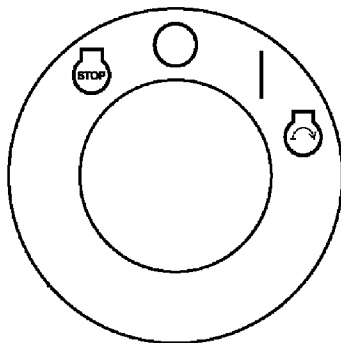

Illustration 150

g02362719



OFF – Insert the engine start switch key only while the start switch is in the OFF position. Remove the engine start switch key only while the engine start switch is in the OFF position. Turn the engine start switch to the OFF position before you attempt to restart the engine. Turn the engine start switch to the OFF position to stop the engine.



ON – To activate the electrical circuits in the cab, turn the key clockwise to the ON position.



START – To start the tractor engine, turn the key clockwise to the START position. After the engine starts, release the key. The key will return to the ON position.

Note: If the engine fails to start, return the engine start switch key to the OFF position. Return the key to the start position before you attempt to start the engine again.

Engine Idle Shutdown

This function shuts down the engine after the operator is not operating the machine for a period of time. This function does not shut down other systems, such as the AC, which can run down the battery after idle shutdown. This function comes disabled from the factory but can be enabled and adjusted in the monitoring system. Refer to Operation and Maintenance Manual, “Monitoring System”.

Note: Engine Idle Shutdown may be required for local regulations.

The Engine Idle Shutdown (EIS) shuts down the engine if the following conditions are met:

- The control lever is in neutral.
- The engine coolant temperature is greater than 70° C (158° F).
- The battery voltage is greater than 24.5V
- The engine speed is less than 2000 rpm.
- The ambient temperature range is between 0° C (32° F) and 30° C (86° F).
- The Back Pressure Valve (BPV) is not working.

Note: If any service tests or calibrations are running the machine will not enter into engine idle shutdown.



Engine Idle Shut down – The action lamp will illuminate and the monitor will display a message 20 seconds before the engine shuts down. An operator can cancel the shutdown by pressing a button on the monitor or move one of the controls.

Operators Seat (9)

The operator seat and the console have various adjustments to meet a wide range of operators. For more information, refer to Operation and Maintenance Manual, “Seat”.

Air Conditioning and Heating Control (10)

If equipped, the switch for the air conditioning and heating control is on the right console.

The heater/air conditioner provides comfort for the operator that is working under various temperature conditions. For more information on the air conditioning and heater controls, refer to Operation and Maintenance Manual, "Air Conditioning and Heating Control".

Radio (11)

This machine may be equipped with a radio. For more information, refer to Operation and Maintenance Manual, "Radio".

Engine Speed Control (12)



Engine Speed – Turn the engine speed dial to control the engine speed (engine rpm). Select the desired position from the ten available positions. The selected position of the engine speed dial is indicated on the electronic monitor panel.



Decrease – Turn the engine speed dial counterclockwise to decrease the engine speed (engine rpm).



Increase – Turn the engine speed dial clockwise to increase the engine speed (engine rpm).

Power Mode (13)



Power Mode – Press this switch to active the power mode settings. The modes that can be selected are: "ECONOMY", "STANDARD HYDRAULIC POWER", and "HIGH HYDRAULIC POWER". For more information, refer to Operation and Maintenance Manual, "Monitoring System".

Travel Speed Control (14)

WARNING

Do not change the setting of the travel speed control switch while you travel. Machine stability may be adversely affected.

Personal injury can result from sudden changes in machine stability.



Travel Speed Control Switch – Press the travel speed control switch to select automatic travel speed or low travel speed. When the engine start switch is on, the travel speed control switch is always set at the **LOW SPEED** position. Whenever the travel speed control switch is pressed, the travel speed changes.



LOW SPEED – Select the **LOW SPEED** position if you travel on rough surfaces or on soft surfaces or if you require a great drawbar pull. Also, select the **LOW SPEED** position if you are loading a machine onto a trailer or you are unloading a machine from a trailer.



AUTOMATIC – If you travel on a hard, level surface at a fast speed, select the **AUTO** position.

Continuous driving at high speed should be limited to 2 hours. If you need to continue driving at high speed for more than 2 hours, stop the machine for 10 minutes. This process will cool down the travel drives before you resume driving.

Automatic Engine Speed Control (15)

The Automatic Engine Speed Control (AEC) automatically reduces engine speed when the machine is inactive. The AEC system is designed to reduce fuel consumption and noise. Lower engine speeds can also increase engine life.

The engine rpm will recover automatically to the setting of the engine speed dial when any hydraulic function is activated. The AEC system operates in three modes. Refer to Table 18 for a description of each mode.



Automatic Engine Speed Control (AEC) – The Automatic Engine Speed Control switch is activated when the engine start switch is turned to the ON position. The indicator lamp will turn on. When you press the AEC switch, the function of the AEC switch changes from ON to OFF. The operator can choose from three possible modes for automatic engine speed control. Refer to Table 18 for more details.

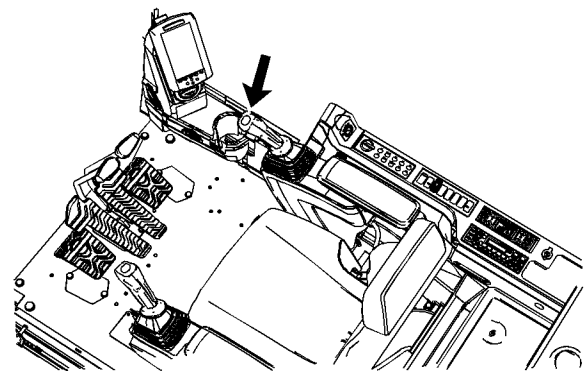

Illustration 151

g02050056

The switch for manual low idle is on the right joystick.

Manual Low Idle – Activate the manual low idle to reduce the engine speed to approximately 1000 rpm. Pressing the switch again will allow the engine speed to return to the original setting of the engine speed dial.

The manual low idle allows the operator to reduce the rpm without touching the engine speed dial. This is useful when the operator wants to reduce the engine speed to talk to someone or while the operator is waiting for a truck.

Operation of the automatic engine speed control depends on the position of the AEC switch and of the switch for manual low idle. The engine rpm will recover automatically to the setting of the engine speed dial when any hydraulic function is activated.

Table 18

AEC Mode	Position of AEC Switch	Setting of Engine Speed Dial	Position of Manual Low Idle Switch	Description of Mode
First stage	OFF	3 to 10	OFF	The electronic controller automatically reduces engine speed by 100 rpm after there has been no hydraulic demand for approximately 3 seconds.
Second stage	ON	3 to 10	OFF	The AEC system in the electronic controller will automatically reduce the engine rpm to approximately 1000 rpm after there has been no hydraulic demand for approximately 3 seconds.
Manual low Idle	ON or OFF	3 to 10	ON	The engine speed is reduced to approximately 1000 rpm.

Travel Alarm Cancel Switch (16)



Travel Alarm Cancel Switch – This switch is used to stop the travel alarm from sounding. Press the switch to stop the alarm. The indicator lamp will turn on.

Note: The travel alarm is located under the hydraulic tank. The travel alarm will sound when the travel lever or the travel pedal is activated.

Work Tool Control (17)



Work Tool Control (Switch) – Press this switch to display the selected work tool on the monitor display. Press the switch repeatedly to change the selected work tool.

Heavy Lift Control (18)

If equipped, push this switch to activate heavy lift mode. Also push this switch to deactivate heavy lift mode.



Heavy Lift Mode – This work mode increases the relief pressure in the hydraulic circuit, which increases the hydraulic force that is available for lifting operations. The cylinder speed is slower when this mode is selected.

Note: During normal excavation work, the heavy lift control must be in the OFF position.

NOTICE

If this machine is used to lift objects within an area that is controlled by the European Directive “2006/42/EC”, the machine must be equipped with a boom lowering control valve, a stick lowering control valve, and an overload warning device.

Window Wiper and Window Washer (19-20)



Window Washer (19) – Push the switch to activate the window washer. While the switch is depressed, the indicator light will come on and washer fluid will spray from the nozzle. The window wiper will also operate while the switch is depressed. After the switch is released for approximately 3 seconds, the window wiper will stop.



Window Wiper (20) – Push the switch to activate the window wiper. Whenever the switch is depressed, the mode of the window wiper will change according to the indicator light that is illuminated.

6 Second Delay – When the window wiper switch is depressed one time, the first indicator light will turn on. The window wiper will operate intermittently at six second intervals.

3 Second Delay – When the window wiper switch is depressed two times, the second indicator light will turn on. The window wiper will operate intermittently at three second intervals.

Continuous Operation – When the window wiper switch is depressed three times, the first indicator light and the second indicator light will turn on. The window wiper will operate continuously.

OFF – When the window wiper switch is depressed four times, the indicator lights will turn off. The window wiper stops.

NOTICE

If the wiper does not operate with the switch in the ON position, turn the switch off immediately. Check the cause. If the switch remains on, motor failure can result.

NOTICE

If the washer is used continuously for more than 20 seconds or used when no washer solution comes out, motor failure can result.

Light Switch (21)

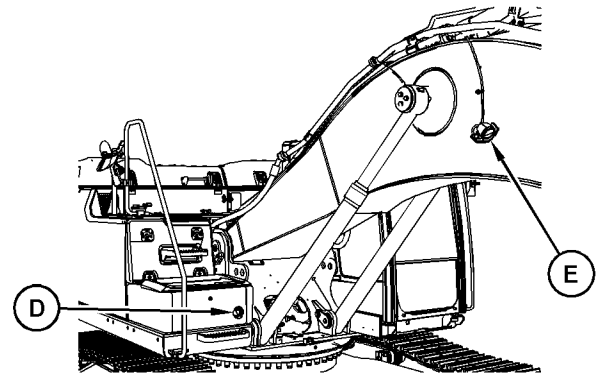

Illustration 152

g02049516

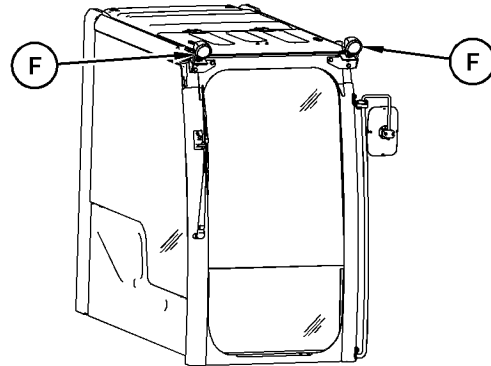

Illustration 153

g02049520



Light Switch – Push the switch to turn on the work lights.

Whenever you push the switch, you change the pattern of the work lights that are turned on. The indicator lights in the cab indicate the pattern of the work lights.

Pattern 1 – When you press the light switch once, the first indicator light turns on. When the first indicator light is on, the following work lights are turned on: work light (D), which is mounted on the chassis, and work lights (F), which are mounted on the cab.

Pattern 2 – When you press the light switch twice, the first indicator light and the second indicator light turn on. When the first indicator light and the second indicator lights are on, the following work lights are

turned on: work light (D), which is mounted on the chassis, work lights (F), which are mounted on the cab and work lights (E), which are mounted on the boom.

OFF – When both of the indicator lights are off, all the work lights are off.

Note: Your machine may be equipped with a lighting system that has a time delay. When this system is installed, cab lights (F) and boom lights (E) will not turn off for a predetermined amount of time after the engine start key has been turned to the OFF position. The time delay can vary from 0 minutes to 5 minutes. For further details, consult your Cat dealer.

Rear/Side View Camera (22)



Rear/Side View Camera – If equipped, push this switch to toggle the images that are shown on the monitor in the cab. For more information, refer to Operation and Maintenance Manual, “Monitoring System”.

Quick Coupler Control (23)

Hydraulic Pin Grabber Quick Coupler

If equipped, the switch for the quick coupler control is on the right console.



LOCKED – Move the switch to this position to engage the quick coupler onto the work tool.



UNLOCKED – Move the switch for the quick coupler to the **UNLOCKED** position to extend the wedge. Use this position only during the coupling or uncoupling of the work tool. The hydraulic system is pressurized when the switch is in this position.

Note: An alarm will sound whenever the switch is in the UNLOCKED or LOCKED position.

For further details, see Operation and Maintenance Manual, “Quick Coupler Operation”.

Quick Coupler



LOCKED – Move the switch to this position to retract the wedge and engage the quick coupler onto the work tool



UNLOCKED – Move the switch for the quick coupler to the **UNLOCKED** position to extend the wedge. Use this position only during the coupling or uncoupling of the work tool. The hydraulic system is pressurized when the switch is in this position.

Note: An alarm will sound whenever the switch is in the UNLOCKED or LOCKED position.

For further details, see Operation and Maintenance Manual, “Quick Coupler Operation”.

Radio Mute Switch (25)



Radio Mute Switch – If equipped, press the switch to mute the radio. The indicator lamp will turn on.

Lower Window Wiper and Window Washer (26-27) (If Equipped)



Lower Window Wiper (26) – Push down on the top of the switch to turn on the lower window wiper. Push down the bottom portion of the switch to turn off the lower window wiper.



Lower Window Washer (27) – Push down on the top of the switch and keep the switch depressed to activate the lower window washer. While the switch is depressed, the washer fluid will spray from the nozzle.

NOTICE

If the wiper does not operate with the switch in the ON position, turn the switch off immediately. Check the cause. If the switch remains on, motor failure can result.

NOTICE

If the washer is used continuously for more than 20 seconds or used when no washer solution comes out, motor failure can result.

SmartBoom Control (28A)

This machine may be equipped with SmartBoom Control. For more information, refer to Operation and Maintenance Manual, "SmartBoom Control".

Fine Swing Control (28B)
 **WARNING**

The Fine Swing Control delays the engagement of the swing parking brake.

If the machine is operating on a slope with the Fine Swing Control in the ON position, the swing motion may become uncontrollable which could result in property damage, personal injury or death.

Turn the Fine Swing Control to the OFF position when the machine is operating on a slope.



Fine Swing Control – If equipped, push down on the top of the switch to activate the fine swing control.

When the fine swing control is ON, the swing parking brake is released. Swing control improves during deceleration of a swing because the swing is allowed to drift instead of stopping abruptly.

Push down on the bottom of the switch to turn off the fine swing control. Operate the machine with the fine swing control in the OFF position when the machine is on a slope. Operate the machine with the fine swing control in the OFF position when great swing forces are required. For example, digging on a sidewall requires great swing force. Operate the machine with the fine swing control in the OFF position to control the motion with the swing brake.

Overload Warning Device (29)

If equipped, the switch for the overload warning device is on the right console.



Overload Warning Device – In lifting applications, the overload warning device activates a buzzer when there is an unstable load condition. When the buzzer sounds, the bucket load should be reduced or the stick should be moved inward.



ON – Push the right side of the switch to activate the overload warning device.



OFF – Push the left side of the switch to deactivate the overload warning device.

Service Port

Illustration 154

g03320855

Electronic Technician service port

An Electronic Technician (ET) service port is located inside the cab behind the seat. This service port allows service personnel to connect a laptop computer that is equipped with Electronic Technician. Service personnel can use electronic technician to diagnose machine and engine systems.

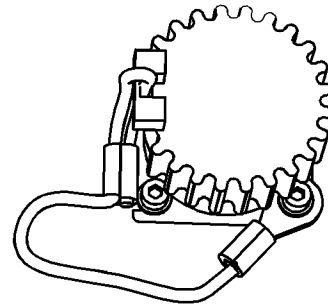
Contact your Cat dealer for additional information.

i05994730

Battery Disconnect Switch

SMCS Code: 1411-B11

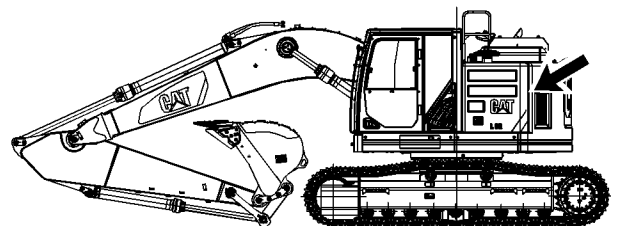

Illustration 155

g03742579

The battery disconnect switch is on the left side of the machine behind the rear access door.

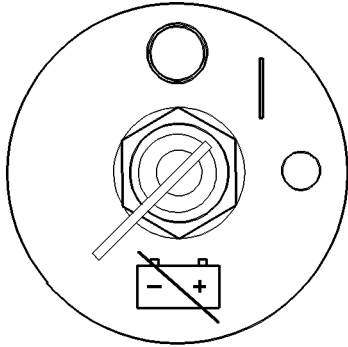

Illustration 156

g00406959



ON – To activate the electrical system, insert the disconnect switch key and turn the battery disconnect switch clockwise. The battery disconnect switch must be turned to the ON position before you start the engine.



OFF – To deactivate the electrical system, turn the battery disconnect switch counterclockwise to the OFF position.

The battery disconnect switch and the engine start switch perform different functions. The entire electrical system is disabled when you turn the battery disconnect switch to the OFF position. The battery remains connected to the electrical system when you turn the engine start switch to the OFF position.

Turn the battery disconnect switch to the OFF position and remove the key when you service the electrical system or any other machine components.

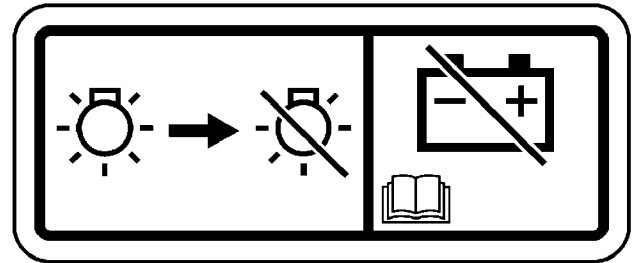

Illustration 157

g03422337

NOTICE

Do not turn off the battery disconnect switch until the indicator lamp has turned off. If the switch is turned off when the indicator lamp is illuminated the Diesel Exhaust Fluid (DEF) system will not purge the DEF. If the DEF does not purge, DEF could freeze and damage the pump and lines.

NOTICE

Never move the battery disconnect switch to the OFF position while the engine is operating. Serious damage to the electrical system could result.

i07742538

Product Link

SMCS Code: 7490; 7606

Note: Your machine may be equipped with the Cat® Product Link™ system.

The Cat Product Link communication device utilizes cellular and/or satellite technology to communicate equipment information. This information is communicated to Caterpillar, Cat dealers, and Caterpillar customers. The Cat Product Link communication device uses Global Positioning System (GPS) satellite receivers.

The capability of two-way communication between the equipment and a remote user is available with the Cat Product Link communication device. The remote user can be a dealer or a customer.

Data Broadcasts

Data concerning this machine, the condition of the machine, and the operation of the machine is being transmitted by Cat Product Link to Caterpillar and/or Cat dealers. The data is used to serve the customer better and to improve upon Cat products and services. The information transmitted may include: machine serial number, machine location, and operational data, including but not limited to: fault codes, emissions data, fuel usage, service meter hours, software, and hardware version numbers and installed attachments.

Caterpillar and/or Cat dealers may use this information for various purposes. Refer to the following list for possible uses:

- Providing services to the customer and/or the machine
- Checking or maintaining Cat Product Link equipment
- Monitoring the health of the machine or performance
- Helping maintain the machine and/or improve the efficiency of the machine
- Evaluating or improving Cat products and services
- Complying with legal requirements and valid court orders
- Performing market research
- Offering the customer new products and services

Caterpillar may share some or all the collected information with Caterpillar affiliated companies, dealers, and authorized representatives. Caterpillar will not sell or rent collected information to any other third party and will exercise reasonable efforts to keep the information secure. Caterpillar recognizes and respects customer privacy. For more information, please contact your local Cat dealer.

Operation in a Blast Site for Product Link Radios

WARNING

This equipment is equipped with a Cat® Product Link communication device. When electric detonators are being used for blasting operations, radio frequency devices can cause interference with electric detonators for blasting operations which can result in serious injury or death. The Product Link communication device should be deactivated within the distance mandated under all applicable national or local regulatory requirements. In the absence of any regulatory requirements Caterpillar recommends the end user perform their own risk assessment to determine safe operating distance.

Refer to your products Operation and Maintenance Manual Supplement, “Regulatory Compliance Information” for more information.

For information regarding the methods to disable the Cat Product Link communication device, please refer to your specific Cat Product Link manual listed below:

- Operation and Maintenance Manual, SEBU8142, “Product Link - PL121, PL321, PL522, and PL523”
- Operation and Maintenance Manual, SEBU8832, “Product Link PLE702, PLE602, PLE601, PL641, PL631, PL542, PL240, PL241, PL141, PL131, PL161, and PL042 Systems”

Note: If no radio disable switch is installed and the equipment will be operating near a blast zone, a Product Link radio disable switch may be installed on the equipment. The switch will allow the Cat Product Link communication device to be shut off by the operator from the equipment control panel. For more details and installation procedures, refer to the following:

- Special Instruction, REHS7339, “Installation Procedure for Product Link PLE640 Systems”
- Special Instruction, REHS8850, “Installation Procedure for the Elite Product Link PLE601, PLE641, and PLE631 Systems”
- Special Instruction, SEHS0377, “Installation Procedure for the Product Link PL131, PL141, and PL161 Systems”

- Special Instruction, REHS9111, “Installation Procedure for the Pro Product Link PL641 and PL631 Systems”

i03903396

Power Receptacle (If Equipped)

SMCS Code: 1436; 7451

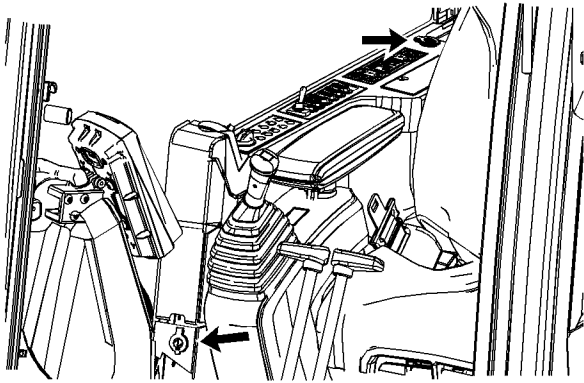

Illustration 158

g02145563

Power Receptacle – Two 12 volt power receptacles are located on the right side console. These power receptacles can be used for powering automotive electrical equipment or accessories. Remove the cap before use.

i07037877

Machine Security System (If Equipped)

SMCS Code: 7631

Operation Section

NOTICE

This machine is equipped with a Caterpillar Machine Security System (MSS) and may not start under certain conditions. Read the following information and know your machine's settings. Your Caterpillar dealer can identify your machine settings.



Machine Security System (MSS) – Machines that are equipped with a Caterpillar Machine Security System (MSS) can be identified by a decal in the operator station. The MSS is a theft deterrent and will prevent the unauthorized operation of the machine.

Basic Operation

MSS may be programmed to use a standard Caterpillar key or an electronic key. The electronic key contains an electronic chip within the plastic housing for the key. Each key emits a unique signal to the MSS. The keys can be identified by a gray housing or a yellow housing. MSS may have programmed settings that require an electronic key for starting during certain periods of time. The MSS may also have programmed settings that allow a standard Caterpillar key to start the machine during certain periods of time.

Note: Ensure that you have only one electronic key near the engine start switch when you are attempting to start the machine. If there is more than one electronic key near the engine start switch the MSS may not be able to read the key in the engine start switch and the machine will not start.

When the engine start switch is turned to the ON position, the ECM will read the unique ID that is stored in the electronic key. The ECM will then compare this ID to the list of authorized keys. The status of the key will be displayed on the monitor. If the key is not authorized for the machine, “UNAUTHORIZED KEY” will be displayed on the monitor.

Note: MSS will not shut down the machine after the machine has started.

Security Management

MSS allows you to program the system to automatically activate at different time periods with different keys. The MSS can also be programmed to reject a specific electronic key after a selected date and time. When you turn the key to the OFF position and the MSS is active, you have a 30 second interval to restart the machine. Also if the machine stalls, there is a 30 second interval for restarting the machine. This 30 second interval is counted from the time of turning the key to the OFF position.

Note: Know your machine's settings because the use of an electronic key is no guarantee that the machine can be restarted.

An expiration date can be set for each electronic key that is contained in the list of keys for the machine. The key will no longer start the machine when the internal clock in the security system passes the expiration date. Each entry in the list of keys can have a different expiration date.

Spare keys are available from your dealer. Before a key can operate the machine, the MSS must be set to accept that particular key. Contact your Caterpillar dealer for information on additional features of the MSS.

Regulatory Compliance Section

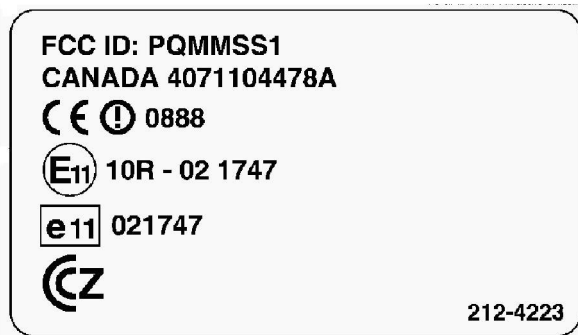

Illustration 159

g00832427

Consult your Caterpillar Dealer with any questions that concern the operation of the MSS in a specific country.

CATERPILLAR			
EC DECLARATION OF CONFORMITY IN RESPECT OF TYPE-APPROVED, TYPE-EXAMINED OR SELF-CERTIFICATION CONSTRUCTION PLANT AND EQUIPMENT			
I, the undersigned, Mark Pfleiderer, hereby certify that the construction equipment component specified hereunder			
1. Category	C. COMPONENT		
2. Make	CATERPILLAR INC.		
3. Type	MACHINE SECURITY SYSTEM (MSS)		
4. Type/serial number of equipment	B	GZ	
5. Year of manufacture	Beginning 2001		
has been manufactured in conformity with			
--EC type-examination (1)			
--EC self-certification (2)			
as shown in the table below			
In the case of EC type-examination/self-examination:			
Directives	No.	Date	Approved Body
99/5/EC	MSS TCF 7-13-01.DOC	2001-05-21	(1) MIRA
73/23/EEC	MSS TCF 7-13-01.DOC	2001-07-13	(2)
89/336/EEC	MSS TCF 7-13-01.DOC	2001-05-29	(1) MIRA
00/02/EC	MSS TCF 7-13-01.DOC	2001-05-29	(1) MIRA
6. Special Provisions...			
Done at Caterpillar Inc. 100 N.E. Adams St. Peoria, IL 61629-AC6130			Signature <i>Mark Pfleiderer</i>
Date 2001-10-03			Mark Pfleiderer Administrative

Illustration 160

g00822256

i06587362

Camera

SMCS Code: 7347; 7348

Rear View Camera (If Equipped)

The rear view camera system consists of a camera that is located in the middle of the top of the counterweight and a "VIDEO MODE SETTING" menu on the monitor.

Note: The rear view camera system has been set up by the factory or by a Cat dealer in order to provide views which comply with specified guidelines. Consult your Cat dealer before any adjustments are made to the system.

For more information refer to Operation and Maintenance Manual, "Monitoring System".

Side View Camera (If Equipped)

The side view camera system consists of a camera that is located on the top of the fuel tank and a "VIDEO MODE SETTING" menu on the monitor.

Note: The side view camera system has been set up by the factory or by a Cat dealer in order to provide views which comply with specified machine right side view. Consult your Cat dealer before any adjustments are made to the system.

For more information refer to Operation and Maintenance Manual, "Monitoring System".

i07350562

Monitoring System

SMCS Code: 7451; 7490

NOTICE

When the monitor provides a warning, immediately check the monitor and perform the required action or maintenance as indicated by the monitor.

The monitor indicator does not guarantee that the machine is in a good condition. Do not use the monitor panel as the only method of inspection. Maintenance and inspection of the machine must be performed on a regular basis. See the Maintenance Section of this Operation and Maintenance Manual.

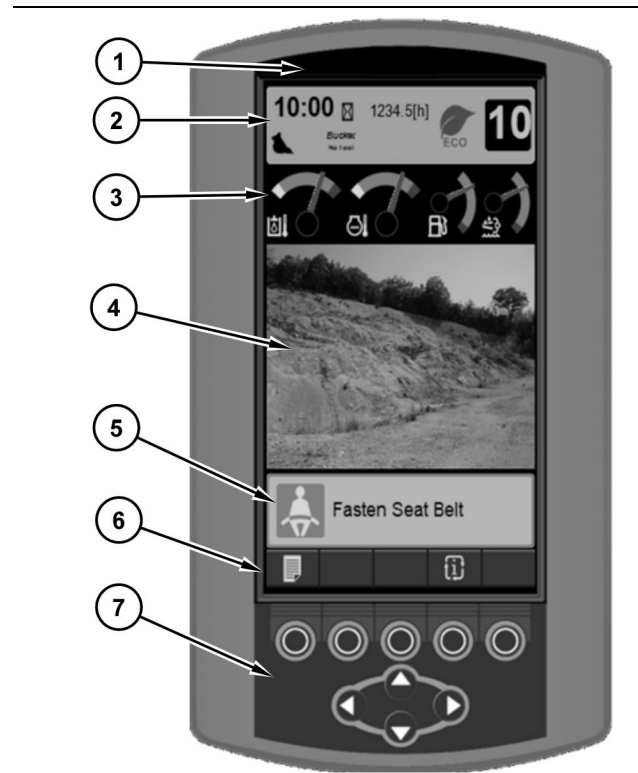

Illustration 161

g03510903

- (1) Alert Lamp
- (2) Clock bar
- (3) Gauges Area
- (4) Camera View
- (5) Warning Display area
- (6) Multi-information area
- (7) Keypad

Action Lamp (1)

This action lamp illuminates to show that a problem has occurred with the machine. The action lamp will flash red when a level 2 warning or level 3 warning is active.

Clock Bar (2)

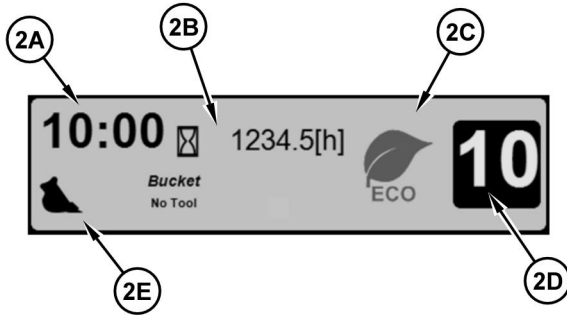

Illustration 162

g03510998

Clock (2A) – The clock function displays the current time.



Service Hour Meter (2B) – This indicator shows the total operating hours of the engine. Use the display to determine the service hour maintenance intervals.



Fuel Consumption Rate (2B) – This indicator shows the rate of fuel consumption.

Fuel Remain Time (2B) – This indicator shows the fuel remaining time.



“ECONOMY MODE SELECTED” (2C) – This indicator shows that the machine is set to operate in the economy mode.

Throttle Dial (2D)

The throttle indicator shows the current position of the throttle dial on the right side panel.

Active Tool (2E)

This indicator shows the current work tool that is selected in the menu.

Gauges (3)



Hydraulic Oil Temperature – This gauge indicates the temperature of the hydraulic oil. The normal operating range is the green range. If the gauge is the white range, the engine and machine warm-up is required. Please refer to Operation and Maintenance Manual, "Engine and Machine warmup". If the gauge reaches the red range, reduce the load on the system. If the gauge stays in the red range, stop the machine and investigate the cause of the problem. White area means Low Temp.



Engine Coolant Temperature – This gauge indicates the temperature of the engine coolant. The normal operating range is the green range. If the gauge is the white range, the engine and machine warm-up is required. Please refer to Operation and Maintenance Manual, "Engine and Machine warmup". If the gauge reaches the red range, stop the machine and investigate the cause of the problem. White area means Low Temp.



Fuel Level – This gauge indicates the amount of fuel that is remaining in the fuel tank. When the fuel gauge indicates that the fuel level is in the red range, add fuel immediately.



Diesel Exhaust Fluid (DEF) Level – This gauge indicates the amount of DEF that is remaining in the DEF tank. When the DEF gauge indicates that the DEF level is in the red range, add DEF immediately.

Camera View (4) (If Equipped)



Illustration 163

g06032090

- (1) Rear View
(2) Side View

This area on the monitor displays the view of the camera. There may be two cameras, a rear view camera mounted on the top of the counterweight and a side view camera mounted on the top of the Fuel tank or Hydraulic oil tank.

If only the rear view camera is equipped, the monitor screen shows a rear view only.

If both rear view camera and side view camera are equipped, the monitor screen is split vertically and displays a rear view (left side on the monitor) and side view (right side on the monitor) simultaneously.

To change the camera view, refer to “Default Screen Preset”

Note: Horizontal guide lines can be enabled/ disabled. Please consult your Cat dealer when you want to change the setting.

Warning Display Area (5)

The Monitoring System is designed to alert the operator to an immediate problem with any of the machine systems that are monitored. The Monitoring System is also designed to alert the operator to an impending problem with any of the machine systems that are monitored. The status of any of those monitored systems will be displayed in this area.

Multi-information Area (6)

This area displays miscellaneous information such as the various work tools or other options such as e-fence that are installed on the machine.

Key Pad (7)

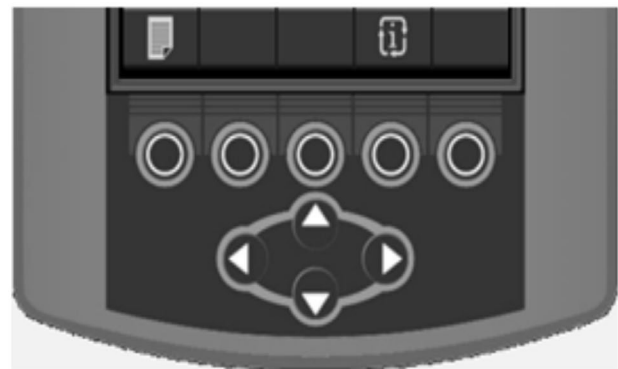

Illustration 164

g03547409

The keypad has nine keys that are used to input information into the electronic monitoring system.



Menu Key – Press the menu key to access the main menu.



Home Key – Press the home key to return to the default display at any time.



Enter Key – Press the enter key to confirm an entry.



Screen Cycle Key – Press the screen cycle key to cycle the different screen views.



OK Key – Press the OK key to select a menu option. Also press the OK key to set values.



Reset Key – Press the reset key to set all counters back to zero.



Back Key – Press the back key to reject a menu option or a setting value. Also, press the back key to return to the previous display.



Up Key – Press the up key to move the cursor upward. Also press the up key to increase values.



Down Key – Press the down key to move the cursor downward. Also press the down key to decrease values.



Left Key – Press the left key to move the cursor to the left. Also press the left key to decrease values.



Right Key – Press the right key to move the cursor to the right. Also press the right key to increase values.

If the fluid level check detects a low fluid level, the appropriate message will be displayed to indicate the fluid level that is low.

Note: If more than one fluid level is low, the symbols for the right key and the left key are indicated in the bottom right area of warning message. Press the right key or the left key to check the other warning message.

Note: The machine cannot perform an accurate fluid level check when the machine is on a slope. Perform the fluid level check on level ground.

The service hours for the filters are checked. The service hours for the fluids are also checked. If a filter or a fluid is over the recommended change interval, "CHECK SERVICE PARTS INFORMATION" appears on the display. Refer to filter and fluid Information located this Operation and Maintenance Manual for more information.

If the engine is started during the prestart checks, the prestart checks are cancelled.

Machine Warnings

Note: All the warnings that are listed may not be applicable to all machine models.

The monitoring system provides three warning categories.

- The first warning category requires only operator awareness. This type of warning will be indicated by a message on the display screen.
- The second warning category requires a change to the machine operation or a change to the maintenance of the machine. This type of warning will be indicated by a message on the display screen and by a blinking of the Action Lamp.
- The third warning category requires immediate shutdown of the engine. This type of warning will be indicated by a message on the display screen, by a blinking of the Action Lamp, and by a buzzer.

If multiple warnings are present in the system, the most important problem is shown first. Press the right key or press the left key to view all the warnings that are present in the machine. If no keys are pressed within 5 seconds, the display will return to the most important problem.

Note: The menu is still functional by pressing the menu key.

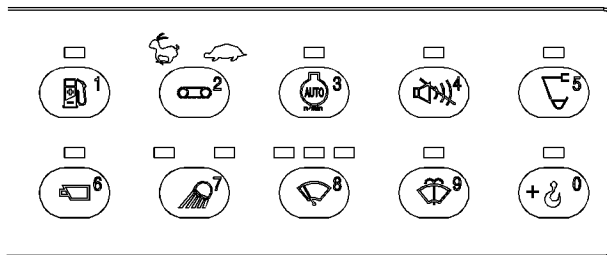

Illustration 165

g03294460

Soft switch panel

Note: The soft switch panel on the right side of the cab can also be used to input numerical values into the monitor.

Prestart Monitoring Function

Turn the engine start switch to the ON position.

After approximately one second, Cat appears in the display and the action lamp turns on.

The pattern for the joystick controls is indicated in the bottom of the display for 3 seconds.

The coolant temperature, the hydraulic oil temperature, the fuel level, and the position of the engine speed dial are now indicated.

The monitoring system checks the level of the engine coolant and the engine oil before the engine starts.

Warning Category 1

In this category, only a warning will be shown in the display screen. This category alerts the operator that the machine system needs attention. Failure of these systems will not endanger the operator. Failure of these systems will not damage the machine components.

Note: The warnings that are listed may not be applicable to all machine models.



“DEF LEVEL LOW” – This warning appears when the DEF level is below the specified level. Add DEF. See this Operation and Maintenance Manual, “Selective Catalytic Reduction Warning System”.



DEF LINES NOT PURGED – Do not turn the battery disconnect switch to the OFF position.



“EMISSION FAULT” – Check for additional warnings. Contact your Cat dealer.



“ENGINE FAULT CHECK ENGINE” – An abnormality has been detected in the engine. Stop the engine and contact your Cat dealer.



“ENGINE OVER SPEED WARNING” – The engine speed is too fast. Change the operating technique. If the situation continues, contact your Cat Dealer.



“ENGINE SHUTDOWN ACTIVE” – An error has occurred with the engine and the engine is shutting down. Contact your Cat Dealer.



“ENGINE SHUTDOWN IDLE TIME EXCEEDED” – The engine is stopped by engine idle shutdown function. Machine shutdown such as air conditioner is pending.



FUEL LEVEL SENSOR FAILURE – The fuel level sensor has failed. Contact your Cat Dealer.



“FUEL PRESSURE HIGH” – The fuel pressure is too high. Contact your Cat Dealer.



“INTAKE AIR FILTER PLUGGED” – The air filter is restricted. Engine output will be decreased. Immediately inspect the air filter. Clean the air filter. Inspect the condition of the air filter. Replace the air filter, if necessary. Perform any necessary repairs. Refer to Operation and Maintenance Manual, “Engine Air Filter Primary Element - Clean/Replace”.



“LOW BATTERY ELEVATED IDLE” – (312F - 320F machine models). The battery voltage is low. Engine idle will be elevated.



“WATER SEPARATOR FULL” – The water separator is full. Drain the water from the water separator as soon as possible. Refer to Operation and Maintenance Manual, “Fuel System Water Separator - Drain”.



“SCR THERMAL MODE REQUIRED” – Stop the operation, place the hydraulic lockout in the LOCKED position and push the start button on the monitor to start cleaning DEF deposit in the SCR system.



“SCR THERMAL MODE ELEVATED IDLE” – Recommend to wait until this message is no longer active. Machine can be operated, but SCR thermal Mode will be needed again. Clean the DEF deposit in the SCR system.

Warning Category 2

Note: The warnings that are listed may not be applicable to all machine models.



“90 % LOAD” – Used with shovel crane applications. The suspended load on the machine is 90% of the rated load. Stop traveling until the machine center of gravity becomes stable or reduce the suspended load. Refer to Operation and Maintenance Manual, “Lifting Capacities” for more information.



“ATTACHMENT FILTER PLUGGED” – The hydraulic filter is restricted. Restriction of the filter will cause hydraulic components to malfunction. Turn the engine start switch to the OFF position and then turn the engine start switch to the ON position. If the warning disappears, the filter is good. Operate the machine on flat ground for at least 10 minutes. If the warning reappears, replace the filter.



“BATTERY VOLTAGE IRREGULAR” – The electrical charging system is malfunctioning. Check the electrical components of the charging circuit immediately. Perform any necessary repairs.



“BOOM OUT OF WORK AREA” – Used with shovel crane applications. The boom cylinder is extended to the point near stroke end. Lower the boom and use a different position for the boom.



“CHECK LINKAGE MEASURE” – There is an abnormality detected in one of the grade control linkage settings. Verify that the linkage settings are correct. Contact your Cat dealer.



“CHECK MACHINE DIMENSION” – There is an abnormality detected in one of the grade control dimension settings. Verify that the machine dimensions are set correctly. Contact your Cat dealer.



“COOLANT TEMP POWER DERATE” – The coolant temperature is too high. The engine will derate until the coolant temperature decreases to the correct level. If the warning stays on during low idle, stop the engine and inspect the cooling system. Perform any necessary repairs as soon as possible.



“CYCLE THE LOCK LEVER” – An error has occurred with the lock lever. Cycle the lock lever.



DEF PURGE ACTIVE – DEF system is purging. Do not turn the battery disconnect switch to the OFF position until the purge is complete.



“E-FENCE SYSTEM INTERFERING” – Used with E-Fence application. The machine is operating at or near the E-fence automatic stop parameters. Operate the machine outside of the E-fence automatic stop parameters.



“EMISSION FAULT” – Check for additional warnings. Contact you Cat dealer.



“ENGINE FAULT CHECK ENGINE” – An abnormality has been detected in the engine. Stop the engine and contact your Cat dealer.



“ENGINE OIL PRESS LOW” – The engine oil pressure is low. Stop the machine and check the engine oil level. If the engine has started in the cold ambient, warm up the machine properly. If the error disappears after warmup, there is no engine oil pressure trouble.



“ENGINE SHUTDOWN PENDING” – The engine idle function will shutdown the engine in 20 seconds. Operator can cancel the shutdown by pressing a button on the monitor or move one of the controls.



“FUEL LEVEL LOW” – The fuel in the tank is low on fuel. Refill the fuel tank.



“GRADE CONTROL CHECK SENSOR” – There is an abnormality detected in one of the grade control sensors. Contact your Cat dealer.



“HOOK INTERFERING” – Used with shovel crane applications. The lifting height is too high. Lower the boom or retract the arm.



“HYD OIL TEMP HIGH (TOOL)” – The hydraulic oil temperature is too high. Stop operating the machine and run the engine at low idle until the hydraulic oil temperature decreases to the correct level. If the warning stays on during low idle, stop the engine. Check the hydraulic oil level and check the hydraulic oil cooler for debris. Perform any necessary repairs as soon as possible.



“HYD OIL TEMP POWER DERATE” – The hydraulic oil temperature is too high. The engine will derate until the hydraulic oil temperature decreases to the correct level. If the warning stays on during low idle, stop the engine. Check the hydraulic oil level and check the hydraulic oil cooler for debris. Perform any necessary repairs as soon as possible.



“HYD RETURN FLTR PLUGGED” – The hydraulic return filter is restricted. Restriction of the filter will cause hydraulic components to malfunction. Turn the engine start switch to the OFF position and then turn the engine start switch to the ON position. If the warning disappears, the filter is good. Operate the machine on flat ground for at least 10 minutes. If the warning reappears, replace the return filter cartridge. Refer to Operation and Maintenance Manual, “Hydraulic System Oil Filter (Return) - Replace”.



“LIFT OVERLOAD WARNING” – The load on the machine is too heavy. The machine is in danger of tipping. Reduce the load immediately. Refer to Operation and Maintenance Manual, “Lifting Capacities” for more information.



“SECURITY SYSTEM ACTIVE” – This machine is equipped with a Machine Security System. The key that is in the ignition switch is not an authorized key. Remove the key and insert an authorized key.



“SERVICE REQUIRED” – The machine has detected a malfunction. Contact your Cat Dealer.



“STICK OUT OF WORK AREA” – Used with shovel crane applications. The stick is retracted from the vertical position. Extend the stick and use a different position for the stick.



“TOOL CONTROL MALFUNCTION” – The work tool has malfunctioned. Stop the machine and inspect the work tool.



“TRAVEL WITH LIFT OUT OF WORK AREA” – Used with shovel crane applications. The machine is traveling with a suspended load that exceeds 70% of the rated capacity. Stop traveling until the machine center of gravity becomes stable or reduce the suspended load.



“WATER SEPARATOR FULL” – The water separator is full. Drain the water from the water separator as soon as possible. Refer to Operation and Maintenance Manual, “Fuel System Water Separator - Drain”.



“REFUELING PUMP STRAINER PLUGGED” – The refueling pump strainer is restricted. Refer to Operation and Maintenance Manual, “Refueling Pump Strainer - Clean”.



“REFUELING PUMP RUNS DRY” – The refueling pump has run dry or plugged. Immediately inspect the fuel transfer pump components, if necessary. Perform any necessary repairs. Refer to Operation and Maintenance Manual, “Fuel Transfer Pump (Refueling)”.



“REFUELING PUMP CONDITION NOT MET” – The fuel transfer pump will not activate and/or stop operating when conditions are not met. Refer to Operation and Maintenance Manual, “Fuel Transfer Pump (Refueling)”.



“SCR THERMAL MODE REQUIRED” – Stop the operation, place the hydraulic lockout in the LOCKED position and push the start button on the monitor immediately.



“EMISSIONS OVERRIDE RENEWAL REQUIRED” – Stop the engine and contact your Cat Dealer.



“100% LOAD” – Used with shovel crane applications. The suspended load 100% of the rated load when traveling. The machine is in danger of tipping. Stop traveling until the machine center of gravity becomes stable or reduce the suspended load. Refer to Operation and Maintenance Manual, “Lifting Capacities” for more information.



“COOLANT TEMP HIGH” – The coolant temperature is too high. Stop the engine immediately. Check the coolant level and check the radiator for debris. Refer to Operation and Maintenance Manual, “Cooling System Coolant Level - Check”. Check the fan drive belts for the water pump. Refer to Operation and Maintenance Manual, “Belts - Inspect/Adjust/Replace”. Make any necessary repairs.



“CRANE SYSTEM MALFUNCTION” – Used with the shovel crane application. An abnormality has been detected in the shovel crane system. Stop the lifting operation immediately. Contact your Cat dealer.



“EMISSION FAULT” – DEF System Failure and Engine will stop in 5 minutes. Stop the engine and contact your Cat dealer.



“ENGINE FAULT SHUTDOWN SAFELY” – An abnormality has been detected in the engine. Stop the engine immediately. Contact your Cat dealer.



“ENGINE OIL PRESSURE POWER DERATE” – The engine will derate until the engine oil pressure is at the correct level. If the warning stays on during low idle, stop the engine and check the engine oil level. Perform any necessary repairs as soon as possible.



“HYD OIL TEMP HIGH” – The hydraulic oil temperature is too high. Stop the engine. Check the hydraulic oil level and check the hydraulic oil cooler for debris. Perform any necessary repairs as soon as possible.



“INLET AIR TEMP POWER DERATE” – Inlet air temperature exceeds threshold. Engine speed is restricted. Stop the engine. Determine the cause of the fault and perform any necessary repairs.



“LIFT OVERLOAD WARNING” – The load on the machine is too heavy. The machine is in danger of tipping. Reduce the load immediately. Refer to Operation and Maintenance Manual, “Lifting Capacities” for more information.

Warning Category 3

Note: The warnings that are listed may not be applicable to all machine models.



“QUICK COUPLER UNLOCK” – The quick coupler is not locked. Lock the quick couple before operating the machine.



“SERVICE REQUIRED” – The machine has detected a malfunction. Contact your Cat Dealer.



“Cancel Auto Stop” – Used with shovel crane, UHD, HCR, and E-Fence applications. The automatic stop function is OFF. Operate the machine with extreme caution. As soon as the need is eliminated, turn the automatic stop function ON.



“E-Fence System Malfunction” – Contact your Cat Dealer. Operate carefully because the E-Fence system does not work.

Other Messages

Prestart

Note: The warnings that are listed may not be applicable to all machine models.



CHECK SERVICE PARTS INFORMATION – One of the machines filters has exceeded the recommended change interval. Replace the filter and reset the hours for the filter.



“COOLANT LEVEL LOW” – The coolant level is too low. Stop the machine immediately. Stop the engine and investigate the cause of the fault.



“ENG OIL LEVEL LOW” – The engine oil level is too low. Stop the machine immediately. Stop the engine and investigate the cause of the fault.



“FASTEN SEAT BELT” – Please fasten your seat belt.

Miscellaneous

Note: The warnings that are listed may not be applicable to all machine models.



“BUCKET IN” – Used with shovel crane applications. Fully retract the bucket.



“COOLANT TEMP LOW ELEVATED IDLE” – The coolant temperature is low. Engine idle will be elevated.



“CRANE SYSTEM OFF” – Used with shovel crane applications. The shovel crane function has been turned off.



“ECONOMY MODE SELECTED” – The economy power mode has been selected.



“GLOW ACTIVE WAIT TO START” – If the engine coolant temperature is too low, the glow plugs will be activated. This indicator will appear in the message display when the engine start switch is in the ON position. The engine can be started after the indicator disappears from the message display



“HIGH POWER MODE SELECTED” – The high-power mode has been selected.



“POWER MODE LOCKING” – Power mode has been locked through the power mode setting menu. Refer to this Operation and Maintenance Manual, “Monitoring System”



“QUICK COUPLER LOCKING” – The quick coupler is locking. See this Operation and Maintenance Manual, “Quick Coupler Control”



“STANDARD POWER MODE SELECTED” – The standard power mode has been selected.



“SYSTEM PROTECTION COMPLETE” – Indicates that the DEF purge is complete. When the temperature of the DEF injector is high, an engine cooldown is executed followed by the DEF purge.



“VERIFY TOOL LOCKING” – The quick couple has been locked. Verify that the quick coupler is securely fixed to the work tool.



“WARM-UP MODE POWER DERATE” – If the joysticks are held for more than 30 seconds, the machine ECM will go into the warm-up mode power derate setting. The machine ECM limits the hydraulic pump torque to 50 percent. Release the joysticks to cancel this setting. Refer to Operation and Maintenance Manual, “Engine and Machine Warm-Up”.



**“SCR THERMAL MODE COMPLETED” –
SCR Thermal Management (cleaning
DEF deposit) ended.**

Main Menu

The “Main Menu” allows the operator to view information concerning the machine. This menu also allows the operator to change information concerning the machine.

1. Push the menu key when the default display is active.

Table 19

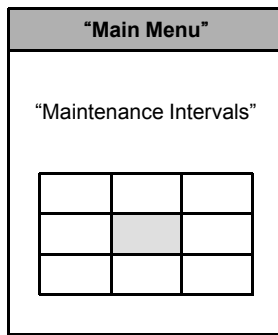

2. The “Main Menu” will be displayed with menu options that are installed on the machine. The number of choices can vary. For more information on these menus, refer to the respective descriptions below.
3. Press the right key or the left key to highlight the desired menu. Press the OK key to open the desired menu.

Note: Press the back key or the home key to exit this menu and return to the default display.

Display Setting

The “Display Setting” menu allows the operator to change the various display settings of the monitor.

1. Press the menu key.

Table 20

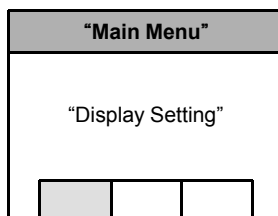

(continued)

(Table 20, contd)

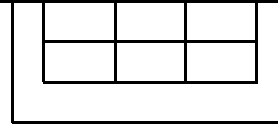

2. Press any of the arrow keys to highlight the “Display Setting” menu. Press the OK key.

Table 21

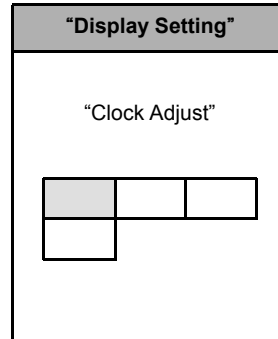

3. The “Display Setting” menu will be displayed with four new menu options. For more information on these menus, refer to the respective descriptions below.

4. Press any of the arrow keys to highlight the desired menu. Press the OK key to open the desired menu.

Note: Press the home key to return to the default display.

Adjusting the Clock

The “Clock Adjust” menu allows the operator to change the time on the clock.

1. Press any of the arrow keys to highlight the “Clock Adjust” menu. Press the OK key.

Table 22

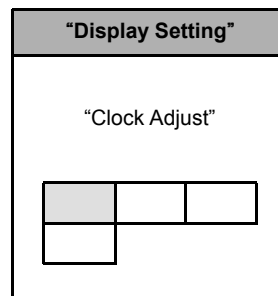

(continued)

(Table 22, contd)



- The "Clock Adjust" menu will be displayed with the current time. Press the left arrow key or the right arrow key to select the hour or the minute. Press the OK key.

Table 23

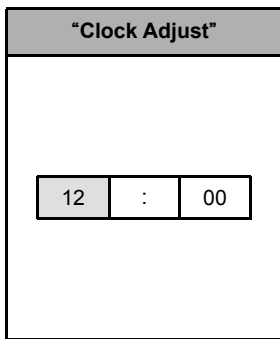

- The hours or the minutes will be highlighted. Press the up arrow key to increase the value. Press the down arrow key to decrease the value.
- When the clock is set to the desired time, press the OK key to save the new time in memory.

Note: Press the back key to return to the previous display without saving.

Note: Press the home key to return to the default display.

Adjusting the Brightness

The "Brightness Adjust" menu allows the operator to change the brightness of the monitor.

- Press any of the arrow keys to highlight the "Brightness Adjust" menu. Press the OK key.

Note: There are two brightness settings. The first setting is used for machine operation during the day. The second setting is used for machine operation at night.

Table 24

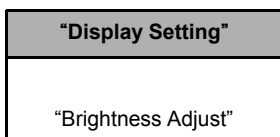

(Table 24, contd)

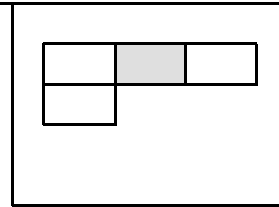

- Press the up arrow key or the down arrow key to select the "Day" setting or the "Night" setting. Press the OK key.

Table 25

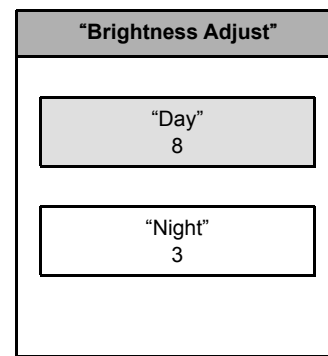

- Press the right key to increase the brightness. Press the left key to decrease the brightness. The brightness can be set between 1 and 10.

Note: Press the home key to return to the default display.

Display Unit Select

The "Display Unit Select" menu allows the operator to change the display units.

- Press any of the arrow keys to highlight the "Display Unit Select" menu. Press the OK key.

Table 26

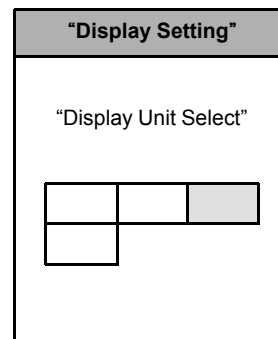

(continued)

- Press the up arrow key or the down arrow key to select the "Metric" setting or the "Imperial" setting. Press the OK key.

Table 27

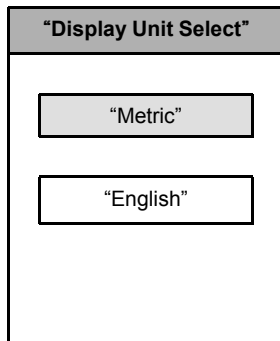

- Press the "Back" key to return to the previous screen or press the "Home" key to return to the main menu.

Default Screen Preset

The "Default Screen Preset" menu allows the operator to change the default screen image when the monitor is turned on.

Note: This menu function is only available when the machine is equipped with a rear view camera or rear view and side view cameras..

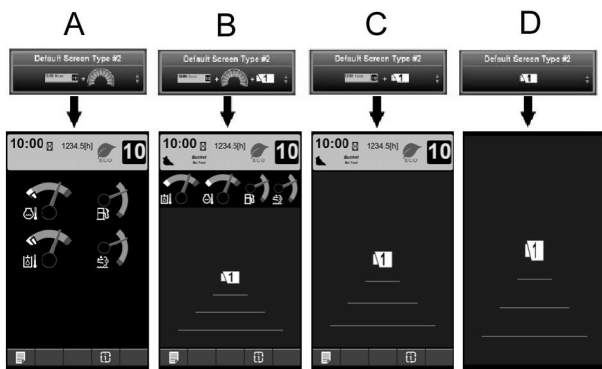

Illustration 166

g03512276

- (Pattern A) Camera view is not displayed, and gauges displayed in large view.
- (Pattern B) Gauges and camera view displayed simultaneously. Pattern B is the default display if the rear view camera or rear view and side view cameras are equipped on the machine.
- (Pattern C) Gauges are not displayed. Large view of rear view camera.
- (Pattern D) Camera view displayed on full monitor screen. Any warnings or events will default to Pattern B.

- Press any of the arrow keys to highlight the "Default Screen Setting" menu. Press the OK key.

Table 28

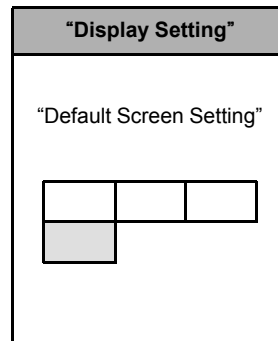

- Press the up arrow key or the down arrow key to select the default screen type. Press the OK key to enter the edit mode.

Note: Default screen #1 is preset at the factory and cannot be changed.

Table 29

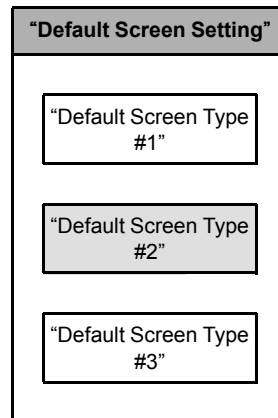

- Press the up arrow key or the down arrow key to select the default screen type. Press the OK key to highlight default screen type. Press the up arrow key or the down arrow key to set the display pattern.

Note: Press the monitor view key to preview the selected default screen.

- Press the OK key to store the pattern that was selected.

- Press the “Back” key to return to the previous screen or press the “Home” key to return to the main menu.

Language Selection

The “Language Select” menu allows the operator to change the language settings.

- Press the menu key.

Table 30

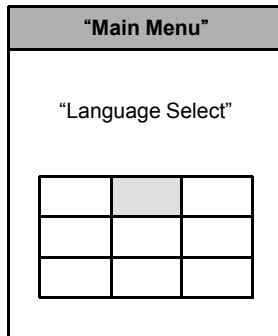

- Press any of the arrow keys to highlight the “Language Select” menu. Press the OK key.

Table 31



- The “Language Select” menu will be displayed with a list of available languages. Press the up key or the down key to scroll through the available languages. Press the OK key to select the desired language.

Note: Press the home key to return to the default display.

Performance

The “Performance” menu allows the operator to view measurements of various system components. The following components are a few examples of the components that can be viewed through the “Performance” menu: battery voltage, engine speed, and pump pressure.

- Press the menu key.

Table 32

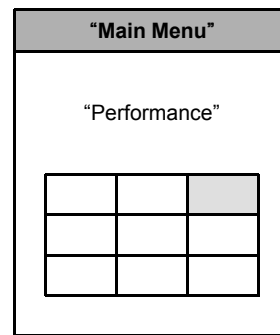

- Press the right key or the left key to highlight the “Performance” menu. Press the OK key.

Table 33

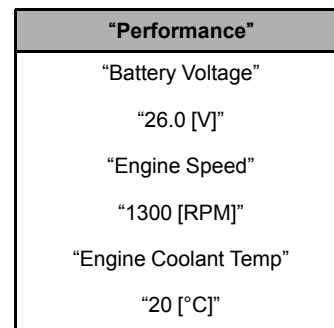

- The “Performance” menu will be displayed with a list of system components and measurements. Press the up key or the down key to scroll through the list.

Note: Press the home key to return to the default display.

Power Mode Setting

The “Power Mode Setting” menu allows the operator to change the various operating power modes.

1. Press the menu key.

Table 34

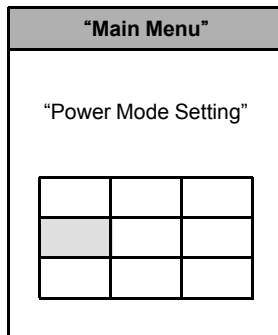

2. Press any of the arrow keys to highlight the "Power Mode Setting" menu. Press the OK key.
3. You will be prompted to enter a password. After the password has been entered successfully, the "Power Mode Setting" menu will be displayed.

Note: When the machine leaves the factory, the password is initially set at 1.

Table 35

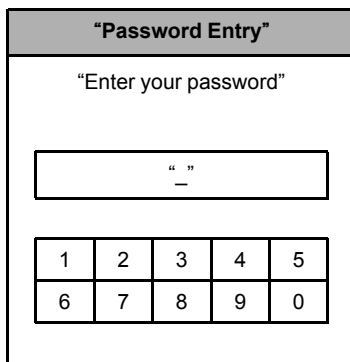

4. Press the up key or the down key to highlight the desired setting. Press the OK key to confirm the desired selection.

Note: Due to country-specific fuel consumption criteria, your machine may not be equipped with all Power Mode options.

Table 36

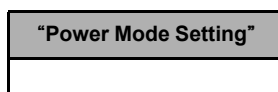

(Table 36, contd)

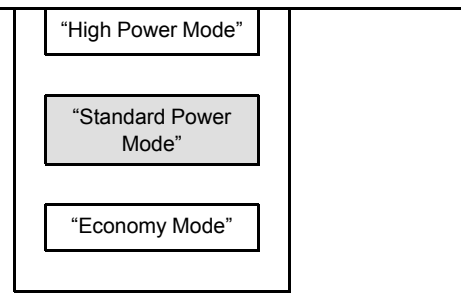

Note: Press the home key to return to the default display.

Maintenance Intervals

The "Maintenance Intervals" menu allows the operator to view the current hours of use and the recommended change intervals for various system components.

1. Press the menu key.

Table 37

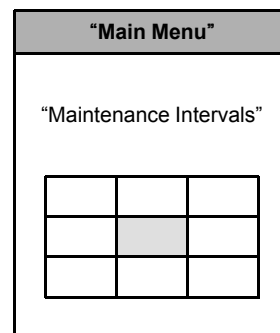

2. Press any of the arrow keys to highlight the "Maintenance Intervals" menu. Press the OK key.

Table 38

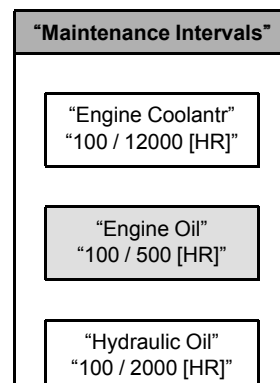

(continued)

(continued)

(Table 38, contd)

--

3. A list of system components will be displayed. Press the up key or the down key to scroll through the list. For each of the system components, the current hours of use will be displayed. If the component has a recommended change interval, the recommended interval will be displayed.

4. Press the reset key to reset the maintenance hours.

Note: Press the home key to return to the default display.

Selecting the Work Tool

The "Work Tool Select" menu allows the operator to change the settings for the work tool.

Note: Make sure that the hydraulic lockout control is in the LOCKED position before you change the settings for the work tool.

Note: If a bucket is installed on the machine, or no work tool is installed, select "Bucket/No Tool" in the menu.

1. Press the menu key.

Table 39

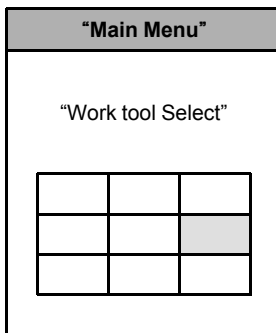

2. Press any of the arrow keys to highlight the "Work Tool Select" menu. Press the OK key.

Table 40

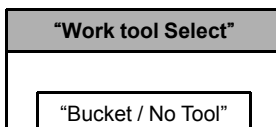

(continued)

(Table 40, contd)

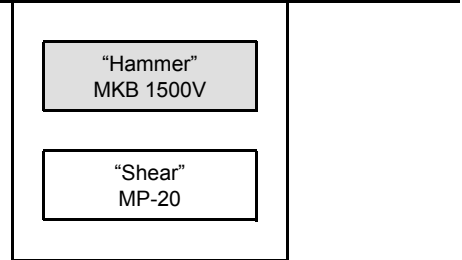

3. Press the up key or the down key to highlight the "Work Tool Select" menu. Press the OK key.

Note: If the work tools have been configured through the Electronic Technician (ET), the names of the work tools will be displayed instead of the numbers.

4. The "Work Tools Select" menu will be displayed with the current options for work tools. Press the up key or the down key to highlight the desired work tool. Press the OK key to select the new work tool.

Note: Press the home key to return to the default display.

Current Totals

The "Current Totals" menu allows the operator to view the current totals for the machines systems.

1. Press the menu key.

Table 41

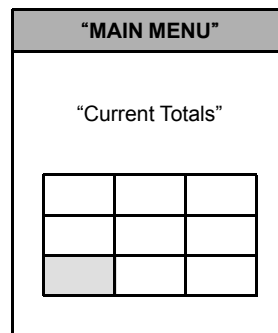

2. Press any of the arrow keys to highlight the "Current Totals" menu. Press the OK key.

Table 42

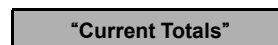

(continued)

(Table 42, contd)

<p>"Total Operating Hours" "12345.6 [hr]"</p>
<p>"Engine" "12345.6 [hr]"</p>
<p>"Hydraulic Pump" "12345.6 [hr]"</p>

3. A list of system components will be displayed. Press the up key or the down key to scroll through the list.

Note: Press the home key to return to the default display.

Engine Shutdown Setting

The "Engine Shutdown Setting" menu allows the operator to enable, disable, or adjust the engine idle shutdown function.

1. Press the menu key. You will be prompted to enter a password. After the password has been entered successfully, the "Shutdown Delay Timer" menu will be displayed.

Note: The password is initially set at "1" when the machine leaves the factory,

Table 43

"MAIN MENU"		
"Engine Shutdown Setting"		

2. The "Shutdown Delay Timer" will appear on the monitor in "BLUE". Press the OK key to activate the edit mode.

Note: The "Shutdown Delay Timer" will appear on the monitor in "GREEN" when the edit mode is activated.

Table 44

"Shutdown Delay Timer"
"OFF"
"3-60 [min]"

3. Press the up key or the down key to change the value. You may select "OFF" to disable the engine idle shutdown function, or select a value between 3 minutes and 60 minutes.

4. Press the OK key to confirm your selection.

Note: The "Shutdown Delay Timer" will appear on the monitor in "BLUE" when the selection has been confirmed.

Note: Press the home key to return to the default display.

Changing the Password

The "PASSWORD CHANGE" menu allows the operator to change the password.

Note: The password is initially set at "1" when the machine leaves the factory,

1. Press the menu key.

Table 45

"MAIN MENU"		
"Password Change"		

2. Press any of the arrow keys to highlight the "Password Change" menu. Press the OK key.

Note: You will be prompted to enter a password.

Table 46

"Password Change"					
"Enter your password"					
" "					
1	2	3	4	5	
6	7	8	9	0	

3. After the password has been entered successfully, the "Enter new password" screen will appear.

Table 47

"Password Change"					
"Enter new password"					
1	2	3	4	5	
6	7	8	9	0	

4. Press any of the arrow keys to select the desired character.

Note: The password is numeric. You may choose from "0" to "9".

5. Press the OK key to enter the character.

Note: Press the back key to delete the last character that was entered.

6. After you enter the password, you will be asked to confirm your selection. Press the "ENTER" key to save the password in memory and return to the "Main Menu" screen. Press the back key to return to the "Password Change" menu without saving the password.

Note: Press the home key to return to the default display.

i03912100

Radio (If Equipped)

SMCS Code: 7338

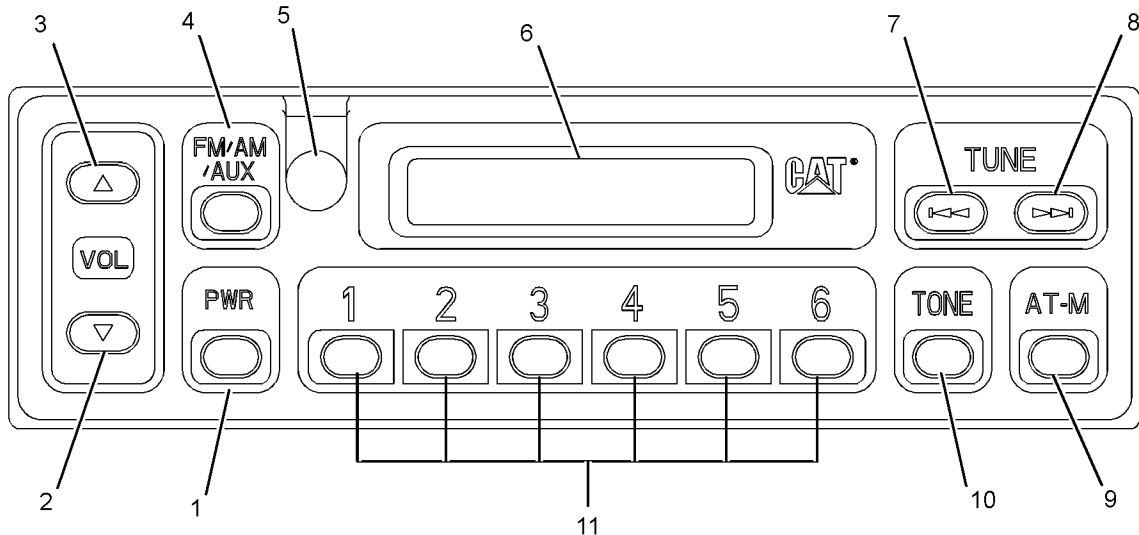

Illustration 167

g02117159

- (1) Power switch
(2) Volume control
(3) Volume control
(4) "AM/FM/AUX" selector

- (5) Auxiliary plug
(6) Display panel
(7) "Tune" button
(8) "Tune" button

- (9) Button for scan and auto memory function
(10) "Tone" control
(11) Preset buttons

Note: When the machine is in operation, turn down the volume of the radio.

Note: The radio can be used only when the battery disconnect switch and the engine start switch are in the ON position.

Note: When a button is pushed, a beep will occur.

(1) Power Switch – Push the power switch in order to turn on the radio. Push the power switch again in order to turn off the radio.

(2) and (3) Volume Control – Push the volume control in order to control the volume. Push the upper volume control in order to increase the sound level and push the lower volume control in order to decrease the sound level.

(4) "AM/FM/AUX" Selector – After you push the "AM/FM/AUX" selector, the selected radio band appears on display panel (6). This button is also used to activate the auxiliary function.

(5) Auxiliary Plug – The front auxiliary plug allows for the connection of a portable audio device.

(6) Display – The display shows various functions such as the station frequency, band, and the volume level.

(7) and (8) "Tune" Buttons – Push the "tune" buttons in order to select a radio station. Pressing "tune" button (7) will decrease the frequency. Pressing "tune" button (8) will increase the frequency. Pressing the "tune" button for less than 0.5 seconds changes the radio station one at a time. Pressing the "tune" buttons for more than 0.5 seconds will change the frequency automatically until a radio station is found.

(9) Scan and Auto Memory – Press button (5) for less than 0.5 seconds in order to listen to 5 seconds of each preset radio station. Press button (5) at least 1.5 seconds in order to store the radio stations with the six strongest signals.

(10) Tone Control – Music is optimized by pressing the tone control so that display (C) will show "MUSIC".

(11) Preset Buttons – The circuitry in the memory system allows you to preset six radio stations. To preset any of the "preset" buttons, follow the "Presetting Radio Stations" procedure.

Presetting Radio Stations

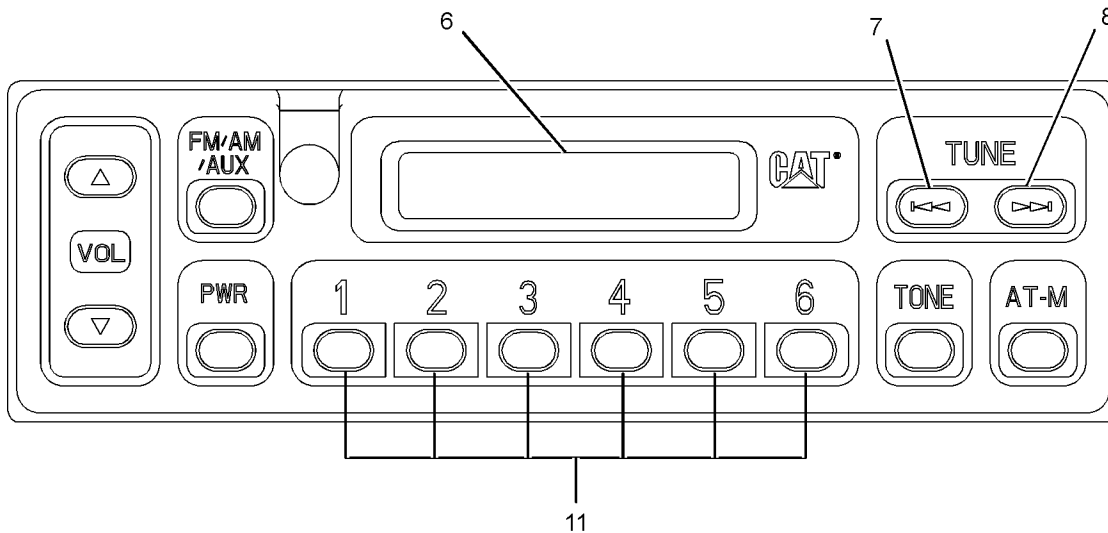

Illustration 168

g02117163

- (6) Display
(7) "Tune" button
(8) "Tune" button
(11) Preset buttons

1. Turn on the radio. Select the AM band or the FM band.
2. Select the first radio station by using tuning switch (7) or tuning switch (8).
3. Depress one of preset buttons (11) for more than 1.5 seconds. The radio station will be stored in the memory for the selected preset.
4. Push preset button (11) in order to tune in the radio station.
5. Repeat the same procedure for the remaining preset switches.

Note: When the preset station is faint, use the “tune” buttons to locate a stronger signal.

Scan and Auto Memory

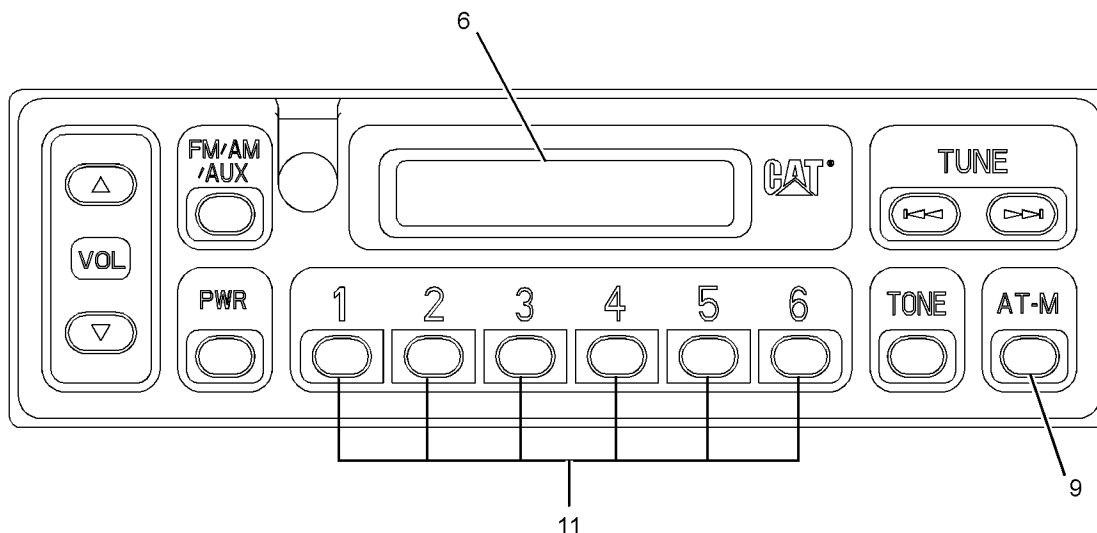

Illustration 169

g02117175

(6) Display (Frequency)

(9) Button for scan and auto memory function

(11) Preset buttons

Scan – Press button (9) for less than 0.5 seconds in order to listen for 5 seconds to each of the preset radio stations. Press button (9) again in order to stop scanning through the preset stations and keep listening to the current station. When this function is used “SCAN” is shown on display (6). The frequency of the radio station is also shown on the display.

Auto Memory – Press button (9) for more than 1.5 seconds in order to store the radio stations that have the strongest signal. The radio stations are stored in the six presets (11). Stations that are already stored in the memory will be erased.

Loss of Memory

The memory system is erased after a few days if the battery is disconnected.

Radio Reception

Note: The radio must be connected to a power source in order to set the area of reception.

Set the area of reception according to the following table:

Table 48

AREA	Display Setting	
	EU	US
North America		X
Central and South America		X
European Union	X	
Asia / Oceania	X	

Use the following procedure in order to set the desired area.

1. Turn off the radio.
2. Press preset button “1” , preset button “4” and button (9) at the same time. Hold until “EU” or “US” is displayed on the display panel.

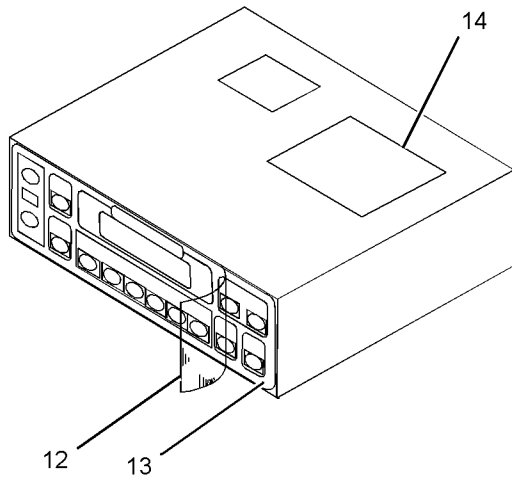

Illustration 170

g02117176

- (12) Protective film
- (13) Control panel
- (14) Method of selection

Note: Remove the film from the radio. Remove the vinyl from the operator seat. The film and vinyl may cause noise interference in the radio.

i06259786

Radio (If Equipped)

SMCS Code: 7338

An AM/FM radio may be installed in the right side instrument panel.

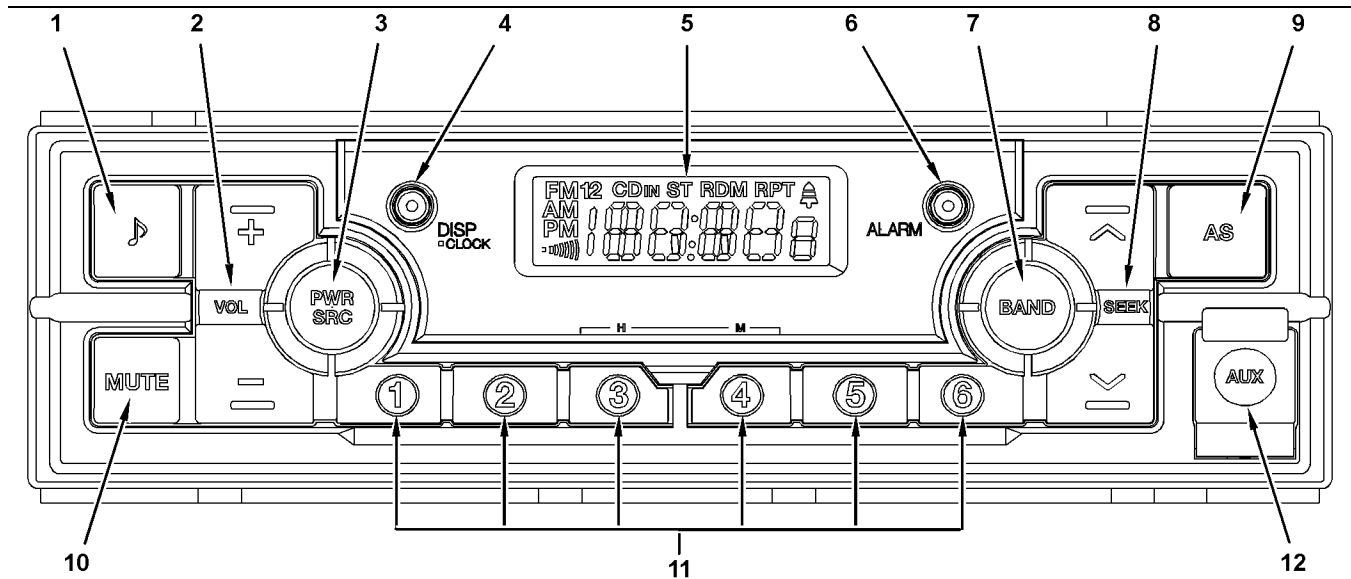

Illustration 171

g02831713

- | | | |
|--------------------------|-----------------------|-----------------------|
| (1) Tone button | (5) Radio display | (9) Auto Store button |
| (2) Volume control | (6) Alarm button | (10) Mute button |
| (3) PWR/SRC button | (7) AM/FM band button | (11) Preset buttons |
| (4) Display/Clock button | (8) Tune button | (12) Auxiliary input |

Note: When the machine is in operation turn down the volume of the radio.

Note: The battery disconnect switch and the engine start switch must be in the ON position in order for the radio to function.

Tone Button (1) – In order to adjust the sound effects and tone, press button (1) and select bass “BA”, treble “TR”, or balance “BA”. Use volume control (2) in order to make adjustments.

Volume Control (2) – Press “+” in order to increase the volume. Press “-” in order to decrease the volume.

PWR/SRC Button (3) – Press the PWR/SRC button in order to turn on the power. Press and hold the PWR/SRC button for 2 seconds in order to turn off the power. With the power on, press the PWR/SRC button in order to change the operation mode to either “RADIO”, “AU1(AUX1)”, or AU2(AUX2).

Display/Clock Button (4) – Press this button once in order to select the desired display in radio display (5). Press and hold this button for 2 seconds in order to switch to the clock setting mode. Use the preset button “3” in order to adjust the hour and preset button “4” in order to adjust the minute. Press the display/clock button again in order to return to the radio display.

Radio Display (5) – Displays information such as the clock, station, and band.

Alarm Button (6) – Press this button once in order to turn the alarm on or off. An alarm indicator will appear in the radio display when the alarm is on.

Press and hold this button for 2 seconds in order to switch to alarm setting mode. Use the preset button “3” in order to adjust the hour and preset button “4” in order to adjust the minute. Press the alarm button again in order to return to the radio display. During the alarm, there will be a beep for 3 minutes, press the alarm button once in order to stop the alarm.

AM/FM Band Button (7) – Press this button in order to switch between FM1, FM2, AM1, or AM2 while in radio mode.

Tune Button (8) – In order to select a radio station manually, press “+” or “-”. In order to select a radio station automatically, press and hold “+” or “-”.

Auto Store Button (9) – Press this button in order to store good reception stations with automatically as one of the 6 preset buttons.

Mute Button (10) – Press this button to turn off the sound immediately. “MUTE” will appear in the radio display. Press this button again in order to return to normal operation.

Preset Buttons (11) – Use tune button (8) in order to select a desired radio station to store. Press and hold one of the preset buttons for 2 seconds in order to store the station in the preset memory.

Auxiliary Input (12) – An external input jack is provided in order to allow playback of sound and music from an external device. Use PWR/SRC button (3) in order to select “AU1”.

Radio Reception Area

This unit is set up to receive the following type of reception area frequencies:

- U.S. Standard
- Other Countries
- Europe Standard

Selecting the Radio Reception Area

Note: All station preset memory will be lost once the reception area is changed.

Press AM/FM band selector (2) and select the desired radio band.

U.S. Standard

While pressing tone button (1), press and hold the number “1” preset button for longer than 2 seconds.

Other Countries

While pressing tone button (1), press and hold the number “2” preset button for longer than 2 seconds.

Europe Standard

While pressing tone button (1), press and hold the number “3” preset button for longer than 2 seconds.

i03767393

Air Conditioning and Heating Control

SMCS Code: 7304; 7320; 7337

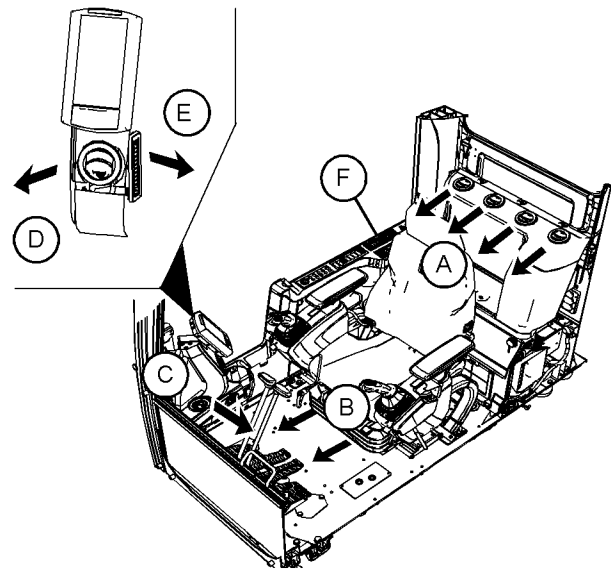

Illustration 172

g02031354

- (A) Vent for upper body
- (B) Floor vent
- (C) Defroster vent
- (D) Defroster Vent
- (E) Vent for upper body
- (F) Control panel

Redirect the louvers for air outlets (A), (C), (D), and (E) by hand to the desired direction. The louvers for air outlet (B) cannot be redirected.

The climate control panel is located under the right window inside the cab:

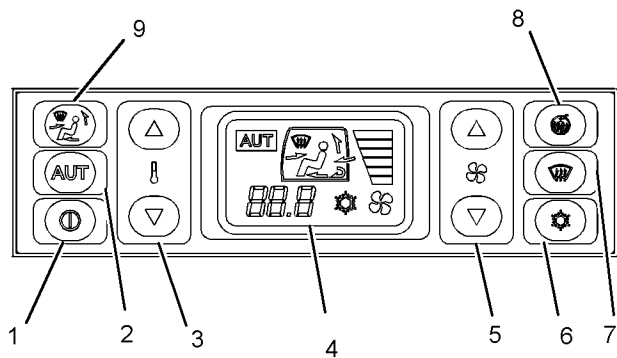

Illustration 173

g02031355

- (1) On/Off switch
- (2) Automatic control switch
- (3) Temperature switch
- (4) LCD panel
- (5) Fan switch
- (6) Compressor switch
- (7) Defrost mode
- (8) Air inlet select switch
- (9) Air outlet select switch



Main Power ON/OFF Switch (1) – Push the ON/OFF switch in order to power on the system. Push the switch again in order to power off the system.



Automatic Control Switch (2) – In order to enter the full “AUT” mode for automatic climate control, push this switch. However, if you push the switch again, you cannot turn off the air conditioning. When the system is in full “AUT” mode, you can manually change specific functions by pushing another switch. If you manually change a specific function, “AUT” does not appear in the display, but the unchanged functions will remain in “AUT” mode. Even on a day that is sunny, a climate control system with only a heater can cool the cab in full “AUT” mode if the ambient temperature is no more than 20 °C (68 °F).

The climate control unit provides excellent operator comfort in the full “AUT” setting. Press the “AUT” switch for full “AUT” mode. Push temperature switch (3) in order to set the desired temperature. The temperature is only shown in metric values. All other functions of climate control will be handled automatically.

In order to take advantage of the full “AUT” setting of the climate control system, always keep the sunlight sensor clean. Do not obstruct the sunlight sensor. If the climate control system is in the full “AUT” setting at engine start-up and the temperature inside the cab is too warm or too cool, the damper for fresh air ventilation may automatically close for a few minutes. This will help to bring the air temperature to the preset temperature more quickly.



Temperature Switch (3) – These switches control the temperature of the air that is coming from the air outlets in order to achieve the preset temperature. This preset temperature appears on LCD panel (4). If the heating and air conditioning system is in the automatic mode, pushing these switches changes the preset temperature.



Increase – Push this switch in order to increase the temperature of the air that is coming out of the air outlets or push this switch in order to increase the preset temperature.



Decrease – Push this switch in order to decrease the temperature of the air that is coming out of the air outlets or push this switch in order to decrease the preset temperature.



Fan Switch (5) – The fan switch directly controls the fan speed. If the climate control system is operating in the automatic mode, pushing this switch overrides the automatically selected fan speed.



Increase – Push this switch in order to increase the fan speed.



Decrease – Push this switch in order to decrease the fan speed.



Compressor Switch (6) – Push the switch in order to turn on the compressor or push the switch in order to turn off the compressor. In humid conditions, the compressor may be used to remove moisture from the air in the cab. In cool weather, operate the compressor weekly in order to prevent leakage of the refrigerant gas. This will also help to maintain the compressor in optimum working order.



Defrost (7) – Depressing this switch will defog the windows. The air will also be dehumidified while the compressor is running. This selection directs air flow out of air outlet (C) and air outlet (D).

Air Inlet Select Switch (8) – This switch selects the position of the air inlet.



Recirculate – When this position is selected, the air inlet is closed. The air will recirculate inside the cab.



Fresh Air – When this position is selected, the air inlet is open. Fresh air will circulate into the cab.

Air Outlet Select Switch (9) – This switch selects the position of each air outlet. Each switch controls a different air outlet.



Upper Body – Selecting this switch will open air outlet (A) and air outlet (D).



Upper Body and Floor – Selecting this switch will open air outlet (A), air outlet (B) and air outlet (D).



Floor – Selecting this switch will open air outlet (B).



Floor and Defroster – Selecting this switch will open air outlet (B) and air outlets (C) and (D).

Consult with your Caterpillar dealer for periodic maintenance of the heating and air conditioning system.

English Versus Metric Toggle

In order to convert the temperature reading from Degrees Celsius to Degrees Fahrenheit, depress both keys of the fan switch at the same time for five seconds. The same action is used for converting the temperature reading from Degrees Fahrenheit to Degrees Celsius.

i03201220

Mirror (If Equipped)

SMCS Code: 7319

WARNING

Adjust all mirrors as specified in the Operation and Maintenance Manual. Failure to heed this warning can lead to personal injury or death.

WARNING

Slips and falls can result in personal injury. Use the machine access systems when adjusting the mirrors. If the mirrors cannot be reached using the machine access systems follow the instructions found within the Operation and Maintenance Manual, “Mirror” in order to access the mirrors.

Note: Your machine may not be equipped with all of the mirrors that are described in this topic.

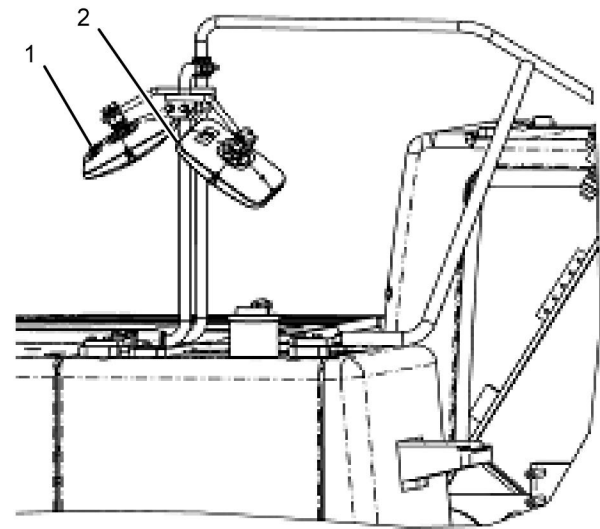

Illustration 174

g01633596

- (1) Rear Mirror on the Tank
- (2) Front Mirror on the Tank

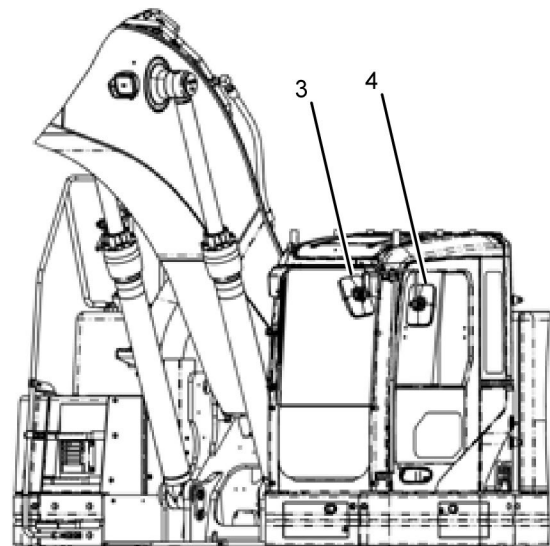

Illustration 175

g01633563

- (3) Front Mirror on the Cab
- (4) Left Mirror on the Cab

Mirrors provide additional visibility around your machine. Make sure that the mirrors are in proper working condition and that the mirrors are clean. Adjust all mirrors at the beginning of each work period and adjust the mirrors when you change operators.

The appropriate job site organization is also recommended in order to minimize visibility hazards. For more information refer to this Operation and Maintenance Manual, “Visibility Information”.

Modified Machines or machines that have additional equipment or attachments may influence your visibility.

Mirror Adjustment

- Park the machine on a level surface.
- Lower the work tool to the ground.
- Move the hydraulic lockout control to the LOCKED position. For further details on this procedure, refer to Operation and Maintenance Manual, “Operator Controls”
- Stop the engine.

Note: You may need to use hand tools in order to adjust certain types of mirrors.

Rear Mirror on the Tank (1)

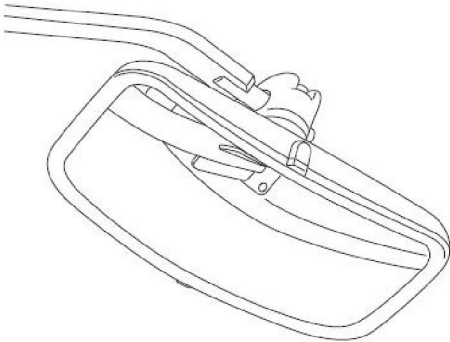

Illustration 176

g01627173

If equipped, adjust the rear mirror on the tank, so the right side of fuel tank and the right access door can be seen from the operator seat. A view of at least 1 m (3.3 ft) from the side of the machine should be seen from the operator seat.

Front Mirror on the Tank (2)

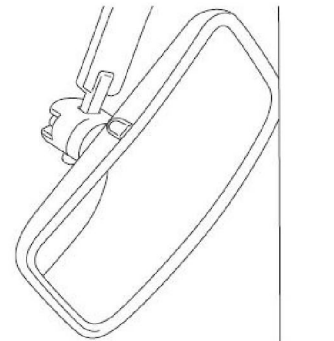

Illustration 177

g01627215

If equipped, adjust the front mirror on the tank (2) so the right access door can be seen from the operator seat. A view of at least 1 m (3.3 ft) from the side of the machine should be seen from the operator seat. Additionally, provide as much visibility to the rear as possible.

Front Mirror on the Cab (3)

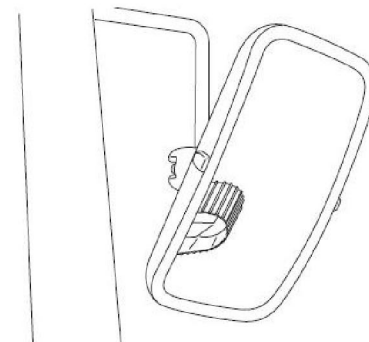

Illustration 178

g01627186

If equipped, adjust the front mirror on the cab (1) so the front of the right track can be seen from the operator seat. A view of at least 1 m (3.3 ft) from the right front of the machine should be seen from the operator seat.

Left Mirror on the Cab (4)

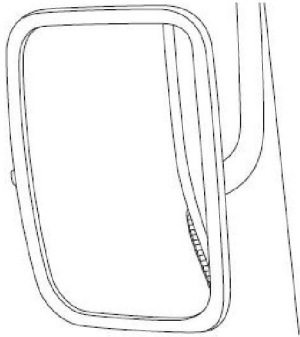

Illustration 179

g01627193

If equipped, adjust the left mirror on the cab (4) so the left side of the cab can be seen from the operator seat. A view of at least 1 m (3.3 ft) from the side of the machine should be seen from the operator seat. Additionally, provide as much visibility to the rear as possible.

i06932588

Window (Front)

SMCS Code: 7310-FR

Note: The cab visor (if equipped) must be down before the front window is raised. The front window will not lock in the overhead storage position with the cab visor in the raised position.

To provide full ventilation inside the cab, the upper window and the lower window can be fully opened.

WARNING

When opening or closing the windows, be extra careful to prevent any personal injury. The hydraulic lockout control must be in the LOCKED position in order to prevent any possibility of sudden movement of the machine due to inadvertent contact with the hydraulic control(s).

Do not change the position of the window until the following items have been done:

- Park the machine on a level surface.
- Lower the work tool to the ground.
- Move the hydraulic lockout control to the LOCKED position.
- Stop the engine.

Perform Step 1 through Step 3 to open the upper window.

Note: If equipped, the Cat Grade Control monitor may interfere with the window when opening. Ensure that the monitor is adjusted out of the way before opening the window.

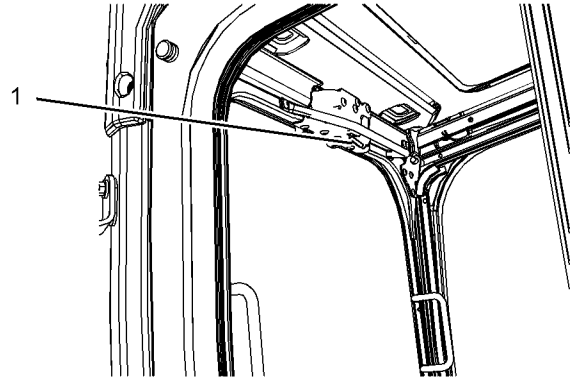

Illustration 180

g02028981

(1) Lever

1. Release the auto-lock latch by moving lever (1) to the right.
2. Hold both grips that are on the window frame. Pull the window upward.

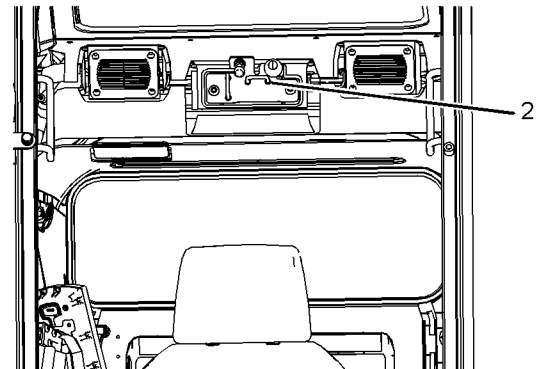

Illustration 181

g02028982

(2) Auto-lock latch

3. Hold both grips that are provided on the window frame and move the window into the STORAGE position until auto-lock latch (2) is engaged.

Perform Steps 4 through 5 to close the upper window.

Note: If equipped, the Cat Grade Control monitor may interfere with the window when closing. Ensure that the monitor is adjusted out of the way before closing the window.

4. Move the lever of the auto-lock latch (1) in the direction of the arrow to release the auto-lock latch.
5. Reverse Steps 1 through 3 to close the upper window.

Perform Steps 6 through 8 to open the lower window and close the lower window.

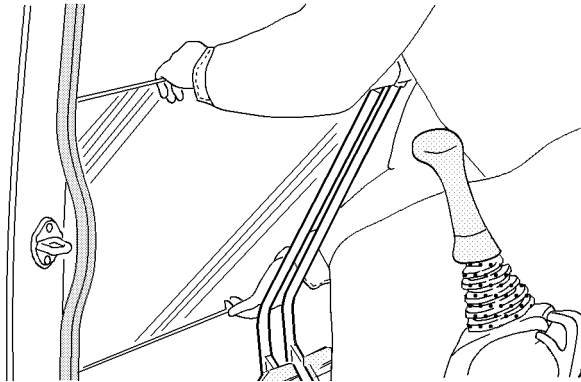

Illustration 182

g00103837

6. Raise the lower window out of the window frame.

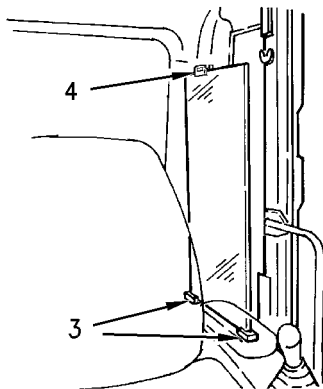

Illustration 183

g00680500

- (3) Brackets
(4) Catch

7. Store the lower window in the holder that is located in the rear of the left side cab frame. To store the lower window, locate one end of the lower window into brackets (3). Secure the opposite end of the lower window with catch (4).
8. To close the lower window, reverse the procedure that is used for opening the lower window.

Note: The lower window is curved. The lower window can only be positioned one way in the holders.

Sun Screen (If Equipped)

SMCS Code: 7165-ZZ

i02500596

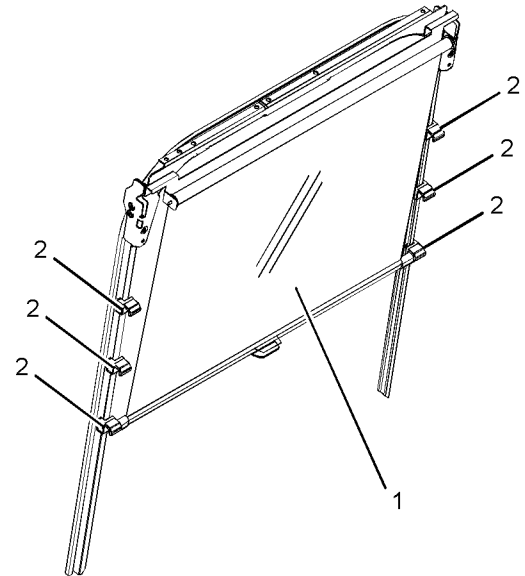

Illustration 184

g01250563

Pull out the sun screen (1). Hook the sun screen to the bracket (2). The sun screen may be positioned in 3 different places.

i01463742

Roof Hatch

SMCS Code: 7303

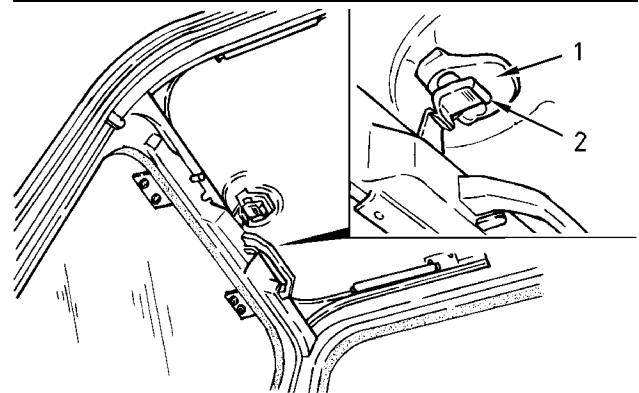

Illustration 185

g00681034

- (1) Grip
(2) Lock

In order to open the roof hatch, release lock (2). Hold grip (1) and push the roof hatch backward.

To close the roof hatch, hold grip (1) and pull the roof hatch forward. Engage lock (2) securely.

i01636325

Cab Door

SMCS Code: 7308

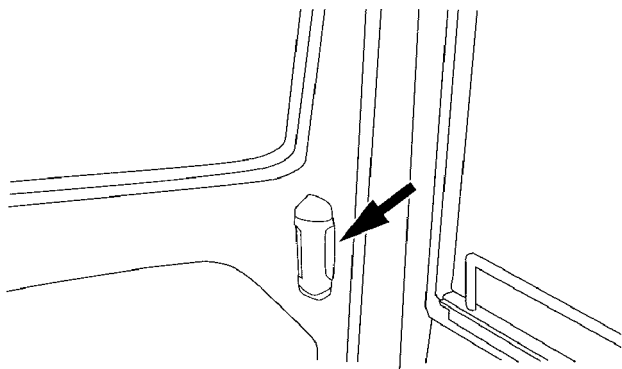

Illustration 186

g00847058

Unlock in order to open the cab door. For additional ventilation, open the cab door all the way and secure the cab door to the catch on the wall of the cab.

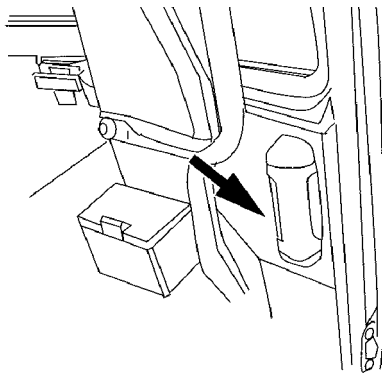

Illustration 187

g00847061

Push the handle to the front in order to open the cab door.

Side Window

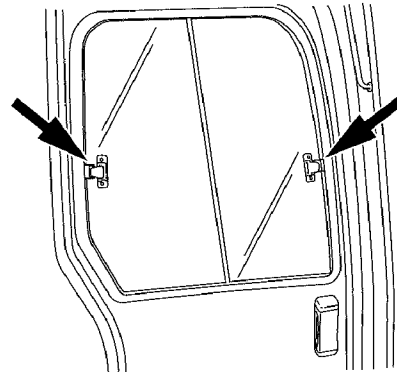

Illustration 188

g00847063

Release the latch and slide the side window to the desired position in order to open the side window. To close the side window, reverse the procedure that is used for opening the side window.

i01447292

Travel Control (Straight Travel Pedal (If Equipped))

SMCS Code: 5462

WARNING

With certain attachment combinations, the third pedal can have different functions. Always check for third pedal function before using the third pedal. Improper operation of the third pedal could result in serious injury or death.

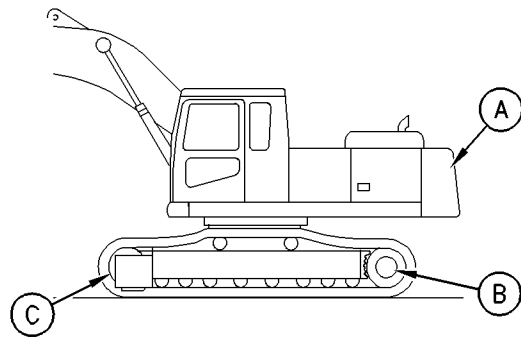

Illustration 189

g00753277

Position for normal travel

- (A) Rear of machine
- (B) Final drive
- (C) Idler

When you travel, make sure that final drive sprockets (B) are under the rear of the machine.

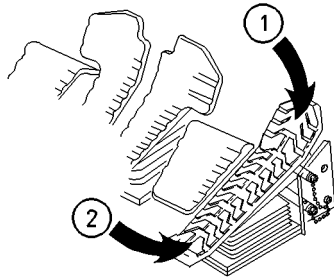

Illustration 190 g00757775

- (1) Forward Travel
- (2) Reverse Travel

The third pedal is to the right of the right travel pedal. The third pedal controls the forward and backward movement of the machine.

Note: If the third pedal is depressed and a travel pedal or a travel lever is operated, the machine will turn accordingly.

Note: To prevent lock pin (3) from being pulled out, insert pin (4) through notch (5) and turn lock pin (3) counterclockwise by 1/4 turn.

i03764090

Joystick Controls (Medium Pressure (If Equipped))

SMCS Code: 5705

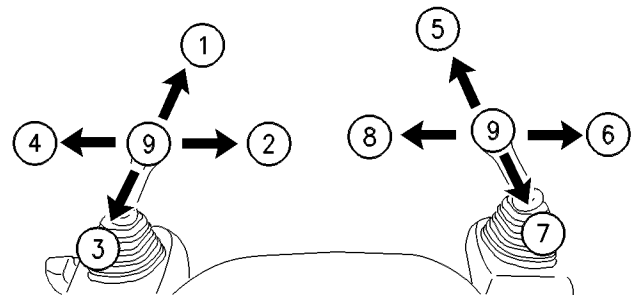

Illustration 192 g00559405

- (1) STICK OUT
- (2) SWING RIGHT
- (3) STICK IN
- (4) SWING LEFT
- (5) BOOM LOWER
- (6) TOOL OPEN
- (7) BOOM RAISE
- (8) TOOL CLOSE
- (9) HOLD

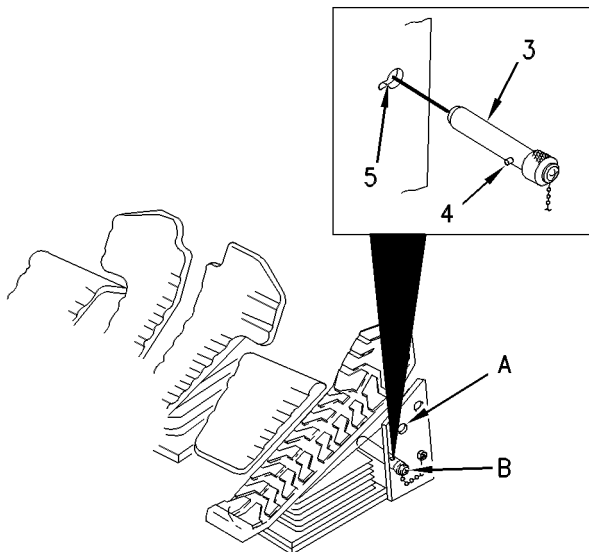

Illustration 191 g00555934

- (3) Lock pin
- (4) Pin
- (5) Notch
- (A) LOCKED position
- (B) UNLOCKED position (STORAGE position)

When the machine is not operated with the third pedal, install lock pin (3) at the LOCKED position in order to prevent accidental operation.

WARNING

The Fine Swing Control delays the engagement of the swing parking brake.

If the machine is operating on a slope with the Fine Swing Control in the ON position, the swing motion may become uncontrollable which could result in property damage, personal injury or death.

Turn the Fine Swing Control to the OFF position when the machine is operating on a slope.

When you release the joysticks from any position, the joysticks will return to HOLD position (9). Movement of the upper structure will stop unless the fine swing control (if equipped) is ON. When the fine swing control is ON, the swing parking brake will not activate until 6.5 seconds after the joystick control for the swing function returns to the HOLD position.

The machine control pattern is initially set at the factory to the SAE system, as shown. The pattern on the left pertains to the left joystick and the pattern on the right pertains to the right joystick.

Operation Section Joystick Controls

The machine control pattern can be varied. Refer to Operation and Maintenance Manual, "Joystick Controls Alternate Patterns" for more information.

Two functions may be performed at the same time by moving a joystick diagonally.

Rotating Tool Control

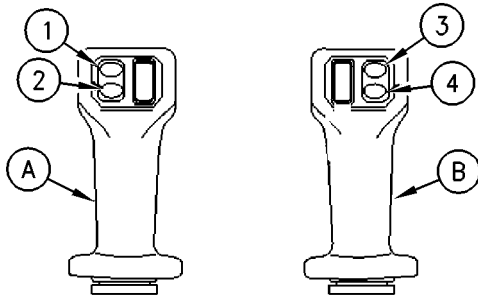

Illustration 193

g00875108

- (A) Left joystick
(B) Right joystick
(1) Medium pressure switch
(2) Horn switch
(3) Medium pressure switch
(4) AEC switch



Rotate Clockwise – Press the medium pressure switch (1) on the left joystick in order to rotate the tool clockwise.



Horn – Press the horn switch (2) on the left joystick in order to activate the horn.



Rotate Counterclockwise – Press the medium pressure switch (3) on the right joystick in order to rotate the tool counterclockwise.



AEC Switch – Press the AEC switch (4) on the right joystick in order to activate low engine speed. Press the switch again in order to activate high engine speed.

i04036189

Joystick Controls

SMCS Code: 5705

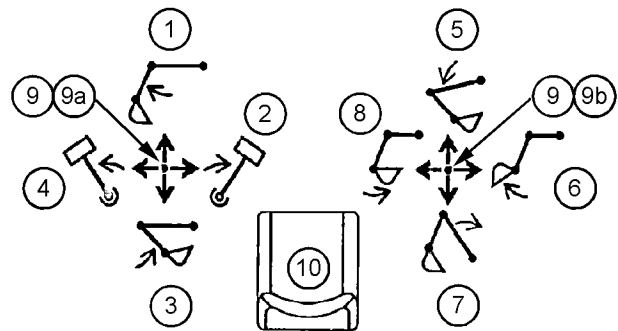

Illustration 194

g02233473

- (1) STICK OUT
(2) SWING RIGHT
(3) STICK IN
(4) SWING LEFT
(5) BOOM LOWER
(6) BUCKET DUMP
(7) BOOM RAISE
(8) BUCKET CLOSE
(9) HOLD
(9a) HORN (IF EQUIPPED)
(9b) AUTOMATIC ENGINE SPEED CONTROL SWITCH (IF EQUIPPED)
(10) Seat

WARNING

The Fine Swing Control delays the engagement of the swing parking brake.

If the machine is operating on a slope with the Fine Swing Control in the ON position, the swing motion may become uncontrollable which could result in property damage, personal injury or death.

Turn the Fine Swing Control to the OFF position when the machine is operating on a slope.

When you release the joysticks from any position, the joysticks will return to HOLD position (9). Movement of the upper structure will stop unless the fine swing control (if equipped) is ON. When the fine swing control is ON, the swing parking brake will not activate until 6.5 seconds after the joystick control for the swing function returns to the HOLD position.

Two functions may be performed at the same time by moving a joystick diagonally.

The machine control pattern is initially set at the factory to the SAE system, as shown. The pattern on the left pertains to the left joystick and the pattern on the right pertains to the right joystick.

The machine control pattern can be varied. Refer to Operation and Maintenance Manual, "Joystick Controls Alternate Patterns" for more information.

i06836341

SmartBoom Control (If Equipped)

SMCS Code: 5461-ZS; 7332

! WARNING

Personal injury or death can result from not following the proper procedures.

To avoid the possibility of injury or death, follow the established procedure.

! WARNING

Activating the SmartBoom function and using the work tool joystick control while the front of the machine is elevated could result in unexpected machine motion. Unexpected machine motion could result in serious injury or death. Do not activate the SmartBoom function if the front of the machine is elevated by the front linkage.

! WARNING

Do not elevate or lower the track when in the SmartBoom mode. Follow the operation procedures for the SmartBoom in the Operation and Maintenance Manual. Failure to follow these instructions can result in serious injury or death.

! WARNING

Always make sure that the boom control joystick is in the NEUTRAL position before activating the SmartBoom control. Activating the SmartBoom control with the joystick out of the neutral position could result in unexpected machine motion which could result in serious injury or death.

! WARNING

Do not select any SmartBoom mode, using the SmartBoom selector switch located on the console, while the tracks are elevated. Selecting the SmartBoom mode with the tracks elevated could result in a sudden drop of the machine which could result in serious injury or death.

! WARNING

If any SmartBoom mode is active and the boom control joystick is in the BOOM DOWN position (forward) with a bucket or a work tool on the ground, pressing the disable button that is located on the front of the right hand joystick could cause a sudden boom down motion. This control function could lift the machine upward, with unexpected machine movement that could result in serious injury or death. Do not press the disable button while the SmartBoom mode is active and the boom control joystick is in the BOOM DOWN position (forward) with a bucket or a work tool on the ground.

! WARNING

Do not attempt to lift the tracks of the machine by using the disable button and applying downward force with the boom lowering control while the machine is in any SmartBoom mode. Releasing the disable button will immediately return the machine to the active SmartBoom mode. This action could cause the machine to drop down abruptly which could result in serious injury or death.

The switches for the SmartBoom are on the right side instrument panel and on the right joystick.

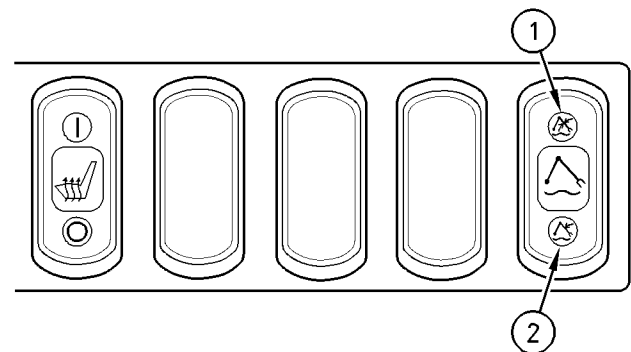

Illustration 195

g00753781

Right side instrument panel

i04477973



(1) SmartBoom UP AND DOWN – Push down on the top of the rocker switch to activate the SmartBoom UP AND DOWN mode. When the boom control joystick is moved to the BOOM DOWN position, the boom will lower by the weight of the boom. The boom can move upward freely.



(2) SmartBoom DOWN – Push down on the bottom of the rocker switch to activate the SmartBoom DOWN mode. The boom will lower by the weight of the boom when the control lever is moved to the BOOM LOWER position. This mode prevents the boom from moving upward. To move the boom upward, the operator must use the boom control joystick to activate the BOOM UP mode.

Note: When the rocker switch for the SmartBoom is in the CENTER position, the SmartBoom is no longer functional.

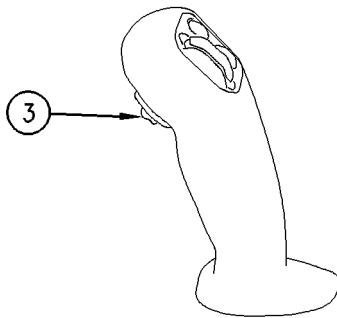

Illustration 196

g00753783

Right Joystick



(3) SmartBoom TEMPORARY DISABLE – Press the trigger switch on the front of the right joystick to temporarily override the SmartBoom function. Release the trigger switch to return to the selected SmartBoom function.

During operation of the SmartBoom, the operator may wish to apply downward force to the boom. When the rocker switch is in the SmartBoom DOWN position or the rocker switch is in the SmartBoom UP AND DOWN position, the operator can disable the SmartBoom function temporarily with the SmartBoom DISABLE switch. While the trigger switch is pressed, BOOM RAISE and BOOM LOWER will operate in the normal modes.

Note: Smart Boom Control function is deactivated when "Reach Front" is selected at "Boom Configuration" on Monitor menu.

Work Tool Control (One-Way Flow) (If Equipped)

SMCS Code: 6700

The following information pertains to work tools that require hydraulic oil flow in one direction. Hydraulic hammers are an example of work tools that require hydraulic oil flow in one direction.

Note: For information that pertains to work tools that require hydraulic oil flow in two directions, refer to Operation and Maintenance Manual, "Work Tool Control (Two-Way Flow)".

Joystick

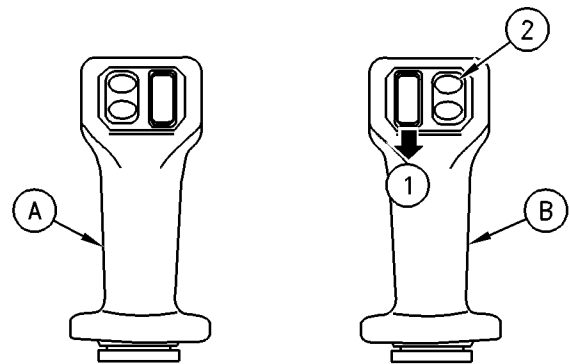

Illustration 197

g00769298

(A) Left joystick
(B) Right joystick



(1) Variable Speed – Move the thumb wheel downward in order to activate the work tool. Move the thumb wheel further in order to increase the speed of the work tool.



(2) On/Off – Push this switch in order to activate the work tool at a constant rate. Push this switch again in order to turn off the work tool.

Work Tool Pedal

WARNING

With certain attachment combinations, the work tool pedal can have different functions. Always check for work tool pedal function before using the work tool pedal. Improper operation of the work tool pedal could result in serious injury or death.

The work tool pedal can be located on either side of the travel pedals. The work tool pedal allows the operator to modulate the speed of the work tool.

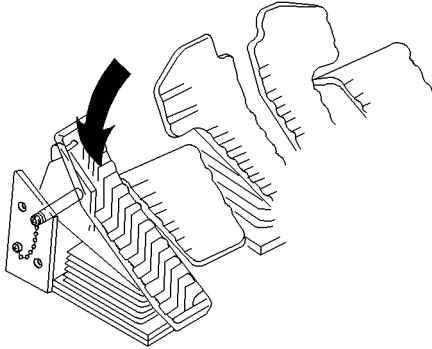

Illustration 198

g00756717



Variable Speed – Push down on the front of the pedal in order to activate the work tool. Move the pedal further in order to increase the speed of the work tool. Release the pedal in order to turn off the work tool.

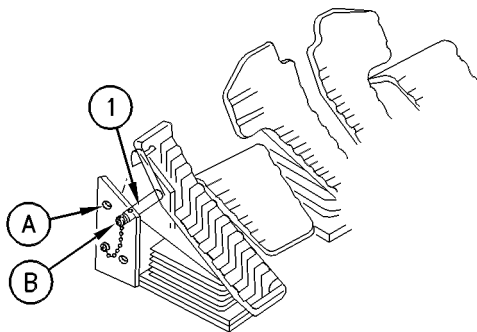

Illustration 199

g00291764

- (1) Lock pin
- (A) UNLOCKED position
- (B) LOCKED position

When you are not using the work tool, put the lock pin (1) in LOCKED position (B). This will lock the work tool pedal in order to prevent any unexpected operation of the work tool.

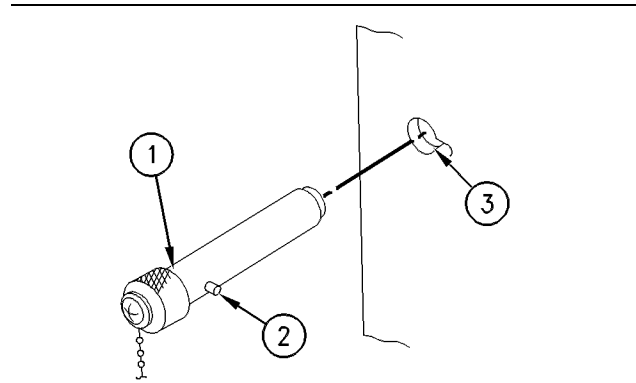

Illustration 200

g00291805

- (1) Lock pin
- (2) Pin
- (3) Notch

Note: To prevent lock pin (1) from being accidentally pulled out, insert pin (2) through notch (3) and turn lock pin (1) counterclockwise by 1/4 turn.

Foot Switch

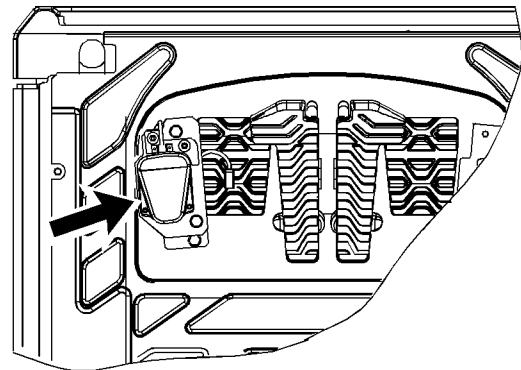

Illustration 201

g02368316

Hydraulic Hammer ON – Push down on the foot switch in order to activate the hydraulic hammer.

Hydraulic Hammer OFF – Release the switch in order to deactivate the hydraulic hammer.

i04477990

Work Tool Control (Two-Way Flow) (If Equipped)

SMCS Code: 6700

The following information pertains to work tools that require hydraulic oil flow in two directions. These work tools can also be equipped with a rotate circuit. Hydraulic shears, pulverizers, crushers, and grapples are examples of work tools that require hydraulic oil flow in two directions.

Note: For information that pertains to hydraulic hammers, refer to Operation and Maintenance Manual, "Work Tool Control (One-Way)".

Joystick

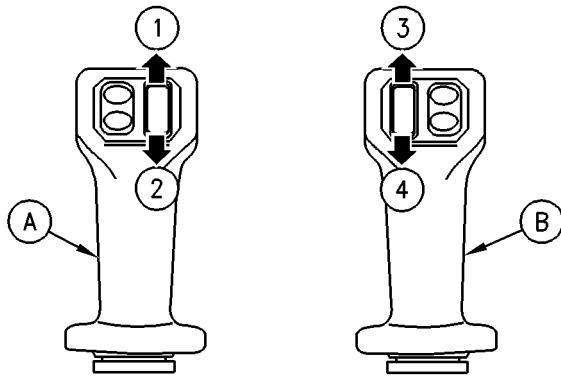

Illustration 202

g00731659

(A) Left joystick
(B) Right joystick



(1) ROTATE CLOCKWISE – Move the thumb wheel upward in order to rotate the work tool clockwise.



(2) ROTATE COUNTERCLOCKWISE – Move the thumb wheel downward in order to rotate the work tool counterclockwise.



(3) CLOSE – Move the thumb wheel upward in order to close the work tool.



(4) OPEN – Move the thumb wheel downward in order to open the work tool.

Work Tool Pedal

⚠ WARNING

With certain attachment combinations, the work tool pedal can have different functions. Always check for work tool pedal function before using the work tool pedal. Improper operation of the work tool pedal could result in serious injury or death.

The work tool pedal can be located on either side of the travel pedals. The work tool pedal allows the operator to vary the speed of the work tool.

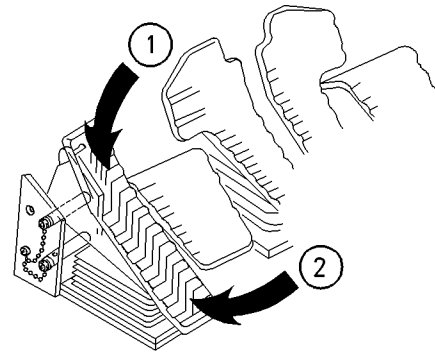

Illustration 203

g00756810



(1) CLOSE – Push down on the front of the pedal in order to close the work tool.



(2) OPEN – Push down on the rear of the pedal in order to open the work tool.

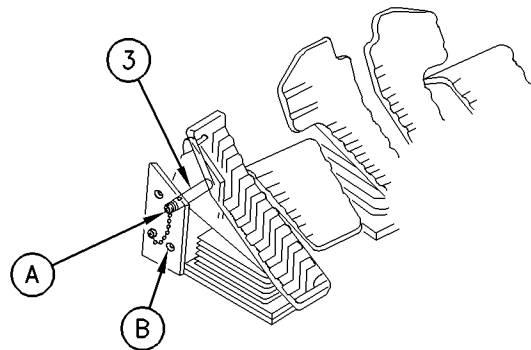

Illustration 204

g00756813

(3) Lock pin
(A) LOCKED position
(B) UNLOCKED position

When you are not using the work tool, put the lock pin (3) in LOCKED position (A). This will lock the work tool pedal in order to prevent any unexpected operation of the work tool.

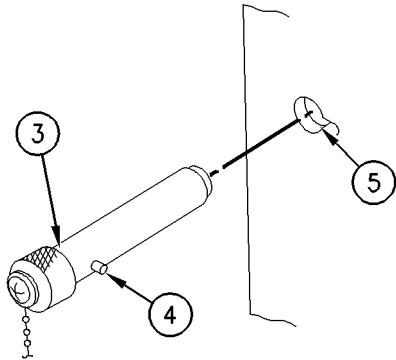

Illustration 205

g00756811

- (3) Lock pin
- (4) Pin
- (5) Notch

Note: To prevent lock pin (3) from being accidentally pulled out, insert pin (4) through notch (5) and turn lock pin (3) by 1/4 turn.

i02624589

Blade Control (If Equipped)

SMCS Code: 5115

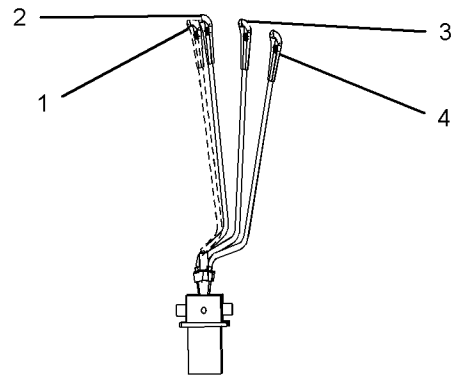

Illustration 206

g01315328

NOTICE

Avoid hitting or moving rocks using the blade. Blade and cylinder damage could occur.

When using the blade as outrigger, be sure to support the machine with the edge of the blade against the ground. When curling the front attachment, do not allow the bucket to hit the blade.

During digging operation, do not allow the boom cylinder to contact the blade edge. When no blade operation is needed, operate with the bucket on the opposite side of the machine from the blade.

Do not swing the upper structure with cab door and/or upper structure covers opened. An opened door and/or cover can hit the blade when the blade is in the raised position while the machine is swinging.



Float (1) – Push the lever forward to the DETENT position. The blade will lower to the ground. The blade will float with the contour of the ground. The lever will remain in the FLOAT until the lever is released from the DETENT position. After the lever is released, the lever will return to the HOLD position.



Lower (2) – Push the lever forward in order to lower the blade. The lever will return to the HOLD position when you release the lever. The blade will remain in the selected position.

Hold (3) – The lever will return to the HOLD position, when you release the lever from the RAISE position or from the LOWER position. The blade will remain in the selected position.



Raise (4) – Pull the lever backward in order to raise the blade. The lever will return to the HOLD position when you release the lever. The blade will remain in the selected position.

i04561876

Joystick Controls Alternate Patterns

SMCS Code: 5059; 5137

Changing Machine Control Pattern By Four-Way Valve (If Equipped)

WARNING

Whenever a change is made to the machine control pattern, also exchange the pattern card in the cab to match the new pattern.

Check the machine control pattern for conformance to the pattern on the card in the cab. If the pattern does not match, change the card to match the machine control pattern before you operate the machine. Failure to do so could result in personal injury.

If the machine is equipped with a four-way valve, the machine control pattern can easily be changed. The machine control pattern can be changed to the SAE pattern, MHI pattern, KOB pattern, or the former SCM pattern by changing the four-way valve position. To change the four-way valve position, use the following procedure.

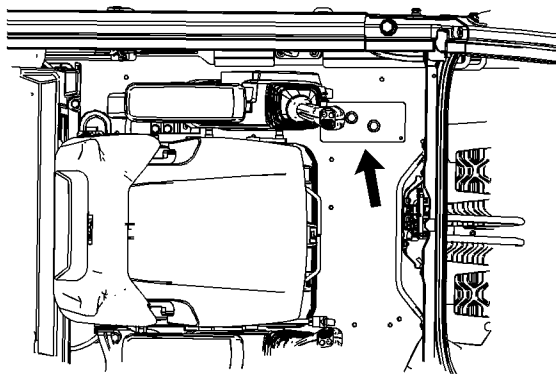

Illustration 207

g02042113

The four-way valve (if equipped) is located underneath the cab floor.

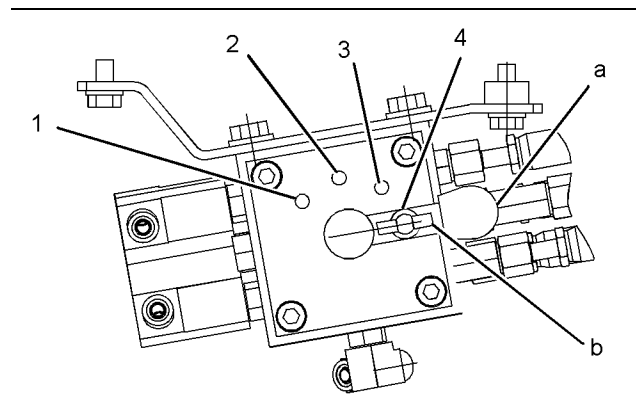

Illustration 208

g02042133

- (a) Lever
- (b) Bolt
- (1) MHI machine control pattern
- (2) CJL machine control pattern
- (3) KOB machine control pattern
- (4) SAE machine control pattern

1. Open the access cover in the floor of the cab.
2. Loosen bolt (b) and move lever (a) to the desired position. The lever can be moved to position (1), (2), (3), or (4).
Position (1) will change the machine control pattern to the MHI pattern. Position (2) will change the machine control pattern to the CJL pattern. Position (3) will change the machine control pattern to the KOB pattern. Position (4) will change the machine control pattern to the SAE pattern.
3. After the pattern is set, tighten the bolt in order to secure the lever.

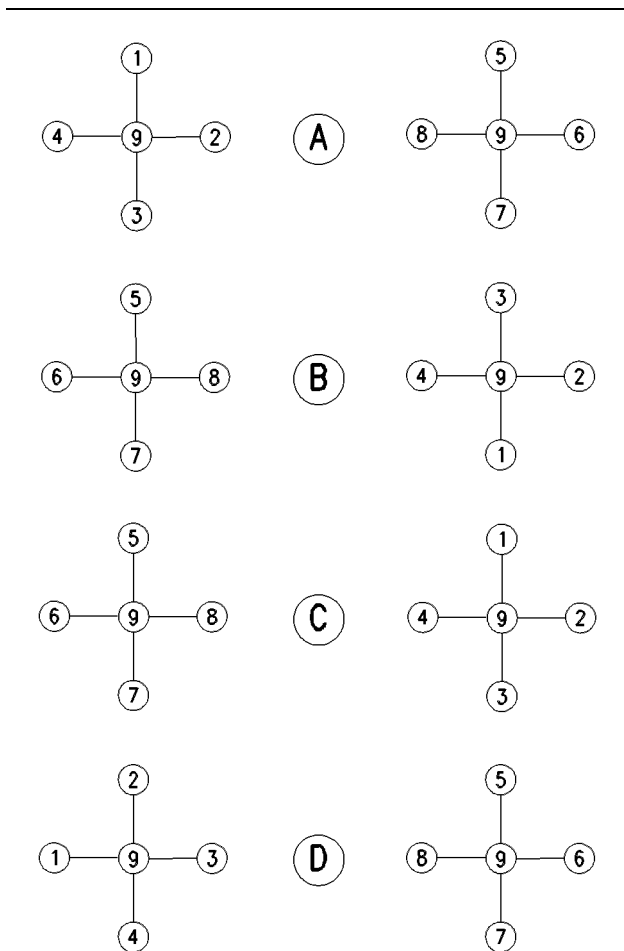

Illustration 209

g00102959

- (A) SAE machine control pattern
(B) MHI machine control pattern
(C) KOB machine control pattern
(D) Former SCM machine control pattern

The patterns on the left side of the illustration show the possible configurations for the left control lever. The patterns on the right side of the illustration show the possible configurations for the right control lever.



STICK OUT (1) – Move the control lever to this position in order to move the stick outward.



SWING RIGHT (2) – Move the control lever to this position in order to swing the upper structure to the right.



STICK IN (3) – Move the control lever to this position in order to move the stick inward.



SWING LEFT (4) – Move the control lever to this position in order to swing the upper structure to the left.



BOOM LOWER (5) – Move the control lever to this position in order to lower the boom.



BUCKET DUMP (6) – Move the control lever to this position in order to dump the bucket.



BOOM RAISE (7) – Move the control lever to this position in order to raise the boom.



BUCKET CLOSE (8) – Move the control lever to this position in order to close the bucket.

HOLD (9) – When the control lever is released from any position, the control lever will return to the HOLD position. Movement of the upper structure will stop.

Two functions may be performed at the same time by moving a control lever diagonally.

If the machine is equipped with a hydraulic hammer, the function of position (6) and of position (8) is different.

HYDRAULIC HAMMER RAISE (6) – Move the control lever to this position in order to raise the hydraulic hammer.

HYDRAULIC HAMMER LOWER (8) – Move the control lever to this position in order to lower the hydraulic hammer.

Changing Machine Control Pattern by Two-Way Valve (If Equipped)

WARNING

Whenever a change is made to the machine control pattern, also exchange the pattern card in the cab to match the new pattern.

Check the machine control pattern for conformance to the pattern on the card in the cab. If the pattern does not match, change the card to match the machine control pattern before you operate the machine. Failure to do so could result in personal injury.

The machine control pattern can easily be changed to the SAE pattern or to the standard backhoe loader hydraulic pattern (BHL) by changing the position of the two-way valve (if equipped). Use the following procedure to change the position of the two-way valve.

Operation Section
Joystick Controls Alternate Patterns

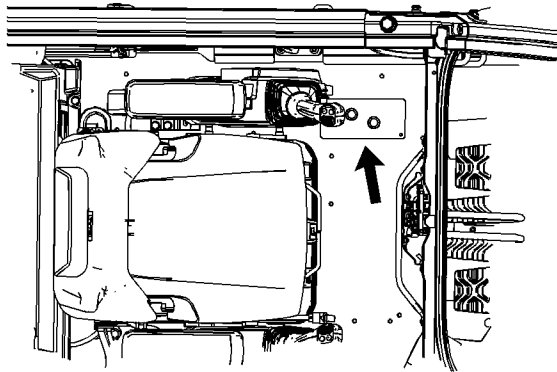

Illustration 210

g02042113

The two-way valve is located underneath the cab floor.

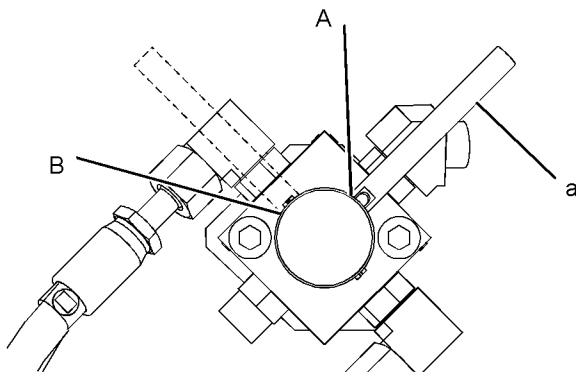

Illustration 211

g02042557

- (a) Lever
- (A) SAE machine control pattern
- (B) BHL machine control pattern

1. Open the access cover in the floor of the cab.
2. Pull up on lever (a) and turn the lever to the SAE position or to the BHL position.

Note: Illustration 211 shows that the two-way valve is in the SAE position.

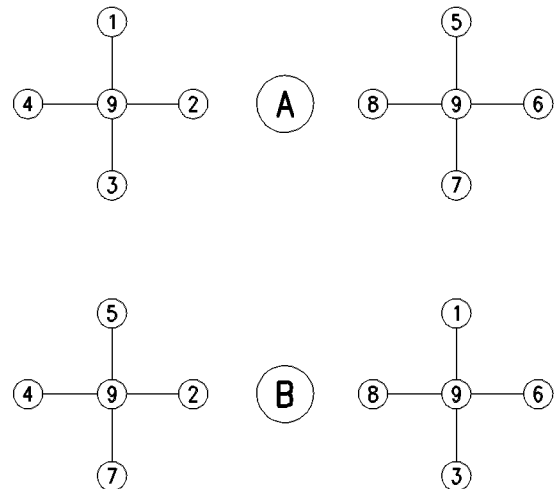

Illustration 212

g00102966

- (A) SAE machine control pattern
- (B) BHL machine control pattern for standard backhoe

The patterns on the left side of the illustration show the possible configurations for the left control lever. The patterns on the right side of the illustration show the possible configurations for the right control lever.



STICK OUT (1) – Move the control lever to this position in order to move the stick outward.



SWING RIGHT (2) – Move the control lever to this position in order to swing the upper structure to the right.



STICK IN (3) – Move the control lever to this position in order to move the stick inward.



SWING LEFT (4) – Move the control lever to this position in order to swing the upper structure to the left.



BOOM LOWER (5) – Move the control lever to this position in order to lower the boom.



BUCKET DUMP (6) – Move the control lever to this position in order to dump the bucket.



BOOM RAISE (7) – Move the control lever to this position in order to raise the boom.



BUCKET CLOSE (8) – Move the control lever to this position in order to close the bucket.

HOLD (9) – When the control lever is released from any position, the control lever will return to the HOLD position. Movement of the upper structure will stop.

Two functions may be performed at the same time by moving a control lever diagonally.

If the machine is equipped with a hydraulic hammer, the function of position (6) and of position (8) is different.

HYDRAULIC HAMMER RAISE (6) – Move the control lever to this position in order to raise the hydraulic hammer.

HYDRAULIC HAMMER LOWER (8) – Move the control lever to this position in order to lower the hydraulic hammer.

fuel supply, turn the fuel shutoff valve counterclockwise.

Note: For more detailed information that pertains to draining the water and sediment from the fuel tank, refer to Operation and Maintenance Manual, “Fuel Tank Water and Sediment - Drain”.

i05969520

Fuel Tank Shutoff and Drain Control

SMCS Code: 1273

The fuel tank drain valve and the fuel shutoff valve are located behind the right access door.

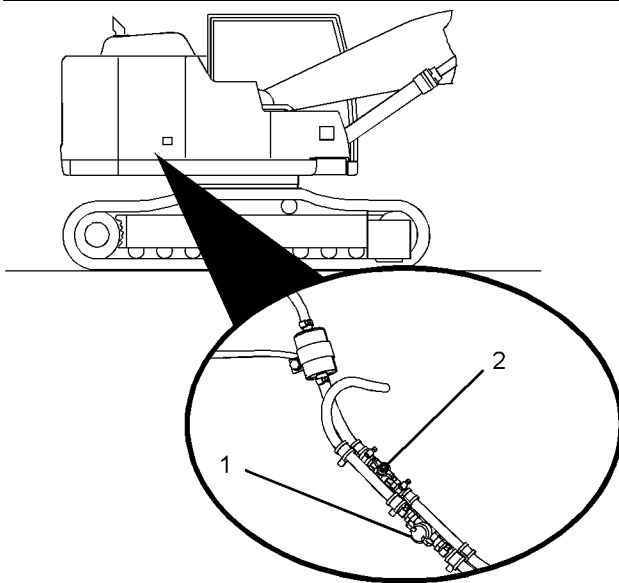

Illustration 213

g03742237

- (1) Fuel Tank Drain Valve
- (2) Fuel Shutoff Valve

Fuel Tank Drain Valve (1) – To drain the water and sediment from the fuel tank, turn the fuel drain valve counterclockwise. To close the fuel tank drain valve, turn the drain valve clockwise.

Fuel Shutoff Valve (2) – To shut off the fuel supply, turn the fuel shutoff valve clockwise. To turn on the

Engine Starting

i04947265

Engine Starting

SMCS Code: 1000; 1090; 1456; 7000

NOTICE

The engine start switch must be in the ON position and the engine must be running in order to maintain electrical functions and hydraulic functions. This procedure must be followed in order to prevent serious machine damage.

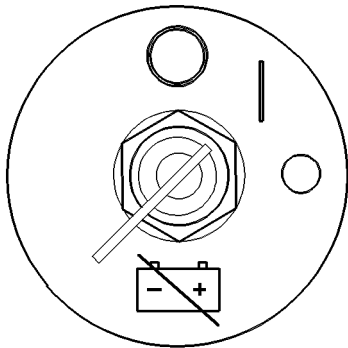

Illustration 214

g00406959

1. Turn the battery disconnect switch to the ON position.
2. Make sure that the reset button for the circuit breaker remains depressed. Refer to Operation and Maintenance Manual, "Circuit Breakers - Reset".
3. Move the hydraulic lockout control to the LOCKED position.

This machine is equipped with an engine neutral start system. The system only allows the engine to start when the lever for the hydraulic lockout control is in the LOCKED position.

4. Move the joysticks to the HOLD position.
5. Before you start the engine, check for the presence of bystanders or maintenance personnel. Ensure that all personnel are clear of the machine. Briefly sound the horn before you start the engine.

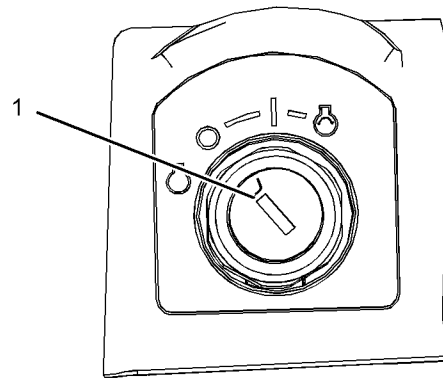

Illustration 215

g02041555

6. Turn engine start switch (1) to the ON position. The monitoring system will start and an indicator message will appear on the monitor display screen for the glow plugs.

Note: Leave the engine start switch in the ON position until the glow plug indicator disappears.

Note: For more information on the monitoring system, refer to Operation and Maintenance Manual, "Monitoring System".

7. If the engine start switch is placed in the ON position for 2 seconds or more, the prestart check of the monitoring system will be activated. If any fluid levels are low, the low fluid level will be shown on the message display. Refer to Operation and Maintenance Manual, "Monitoring System" for more information on the prestart monitoring function.

If the fluid level is too low, add the corresponding fluid to the specified level. Add the fluid before you start the engine.

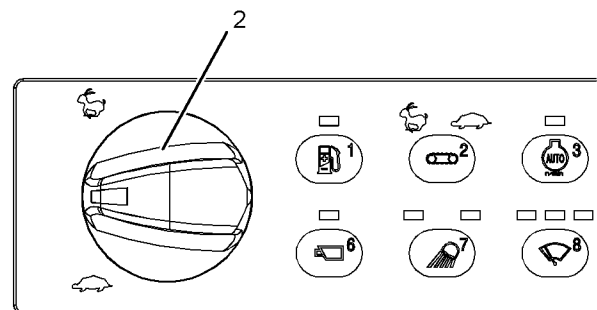

Illustration 216

g02204433

8. Turn engine speed dial (2) to speed position "1".

NOTICE

Do not crank the engine for more than 30 seconds. If the engine does not start, allow the starter to cool for two minutes before cranking again. The engine start switch must be turned to the OFF position before trying to restart.

- Once the glow plug indicator has disappeared from the monitor display screen, you may start the engine. Turn the engine start switch to the START position.

Note: The operating period of the glow plug indicator will change due to the temperature of the engine.

- Release the engine start switch after the engine starts.

This machine's engine with standard specifications can start in areas that have temperatures as low as -18°C (0°F). For areas that are cooler, a starting kit for cold weather is available.

i06970773

Engine and Machine Warm-Up**SMCS Code:** 1000; 7000**NOTICE**

Keep engine speed low and do not operate until the message "Warm-Up Mode Power Derate" on the monitor goes out. If it does not go out within thirty seconds, stop the engine and investigate the cause before starting again. Failure to do so, can cause engine damage.

NOTICE

Always run the engine at low idle for at least ten minutes before performing any other operations in cold conditions or each time the engine oil and oil filter are changed in order to protect your engine and hydraulic components.

NOTICE

Depending on the ambient temperature, in order to prevent the machine operation with high speed without sufficient lubrication at the turbo bearing, the engine speed may be set to low speed and the hydraulic power minimized for a pre-determined time after the engine starts. Refer to turbo protection feature.

The engine may automatically change speeds when the machine is stationary and idling in cold ambient temperature for an extended time. This is to:

- Maintain desired coolant temperature.
- Maintain desired operation of engine systems.

During extended idling in cold ambient conditions, engine speed may operate between 900 rpm and 1000 rpm. Operation at 1000 rpm is minimal and will only last for up to 20 minutes.

Hydraulic System**⚠ WARNING**

When you cycle the machine controls, the machine can move suddenly. Contact between the machine and external objects or ground personnel can result in serious injury or death. Before you cycle the machine controls, the machine should be located in an unobstructed, hazard-free work area that is away from external objects and ground personnel.

- Make sure that the area is clear of personnel and equipment.

Note: The hydraulic lockout control must be in the UNLOCKED position before the hydraulic controls will function.

- Allow the engine to warm up at low idle for at least 5 minutes. Engage the work tool controls and disengage the work tool controls. This will speed up the warm-up of the hydraulic components.

When you idle the machine for warm-up, observe the following recommendations:

- If the temperature is greater than 0°C (32°F), warm up the engine for approximately 15 minutes.
- If the temperature is less than 0°C (32°F), warm up the engine for approximately 30 minutes.
- If the temperature is less than -18°C (0°F) or if hydraulic functions are sluggish, additional time may be required.

NOTICE

The hydraulic oil temperature should be higher than 25°C (77°F) before performing work with the machine. Make sure that the warm-up procedure is performed.

If the hydraulic oil temperature is less than 25°C (77°F) and the machine is operated abruptly, serious damage to the hydraulic components may occur.

Note: The recommended operating temperature of the hydraulic fluid for this machine is 55°C (131°F).

3. To warm up the hydraulic oil, turn the engine speed dial to the medium engine speed.
4. Run the engine for approximately 5 minutes and move the joystick intermittently from the BUCKET DUMP position to the HOLD position. Do not hold the joystick in the BUCKET DUMP position with the bucket cylinder fully extended for more than 10 seconds.

This allows the oil to attain relief pressure, which causes the oil to warm up more rapidly.

5. Turn the engine speed dial to the maximum engine speed and repeat Step 4.
6. Cycle all controls to circulate warm oil through all hydraulic cylinders and all hydraulic lines, and through the swing motor and travel motors.
7. Observe the gauges and the indicators frequently during the operation.



Turbo Protection Power Derate – After an engine start, the engine speed will be set to low speed and the hydraulic power limited for a time period . During this period, the monitor displays the message "Warm-Up Mode Power Derate". (Maximum is around 30 seconds). After the turbo bearing lubrication is sufficient, the engine speed goes to the setting dial speed and the monitor stops to display the message.

Improve Cold Weather Performance

Covers installed over the vents in the radiator compartment door will help to control overcooling in ambient temperatures below -15°C (5°F).

The materials used for the covers and the method used to install the covers is at the installers discretion.

Install the covers if overcooling is observed while the machine is idling in ambient temperatures below -15°C (5°F).

Stop the machine, and remove the covers under the following conditions:

- The ambient temperature is above -15°C (5°F).
- The engine temperature gauge indicates overheating.
- The hydraulic oil temperature gauge indicates overheating.

Installation

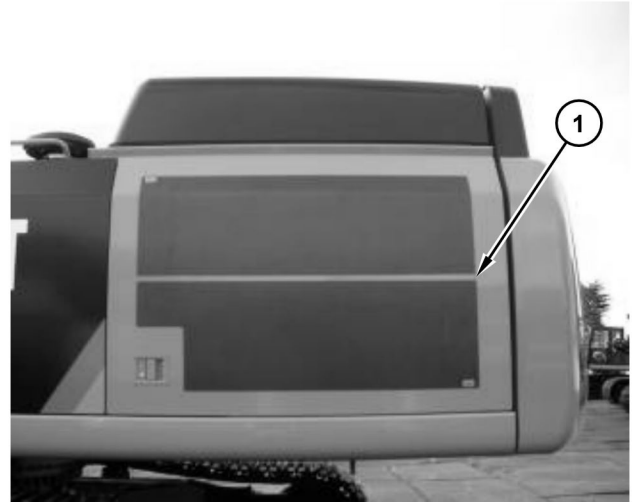

Illustration 217

g03707408

Typical example of cover location on the radiator compartment door

(1) Covers

1. Clean the surface of the radiator compartment door.
2. Install the covers in the location shown in Illustration 217 . The covers should fully cover the door vents.

Operation

i06231546

Operation Information

SMCS Code: 7000

Note: Operating Temperature Range for the Machine The machine must function satisfactorily in the anticipated ambient temperature limits that are encountered during operation. The standard machine configuration is intended for use within an ambient temperature range of $-18\text{ }^{\circ}\text{C}$ ($0\text{ }^{\circ}\text{F}$) to $43\text{ }^{\circ}\text{C}$ ($109\text{ }^{\circ}\text{F}$). Special configurations for different ambient temperatures may be available. Consult your Caterpillar dealer for additional information on special configurations of your machine.

Make sure that no personnel are on the machine or near the machine in order to prevent any personal injury. Keep the machine under control at all times in order to prevent injury.

Sound the horn and allow adequate time for bystanders to clear the area before moving the machine into a restricted visibility area. Follow local practices for your machine application. For more information refer to Operation and Maintenance Manual, "Restricted Visibility".

Reduce the engine speed when you maneuver the machine in tight quarters and when you drive over an incline.

Select the necessary travel speed range before you drive downgrade. Do not change the travel speed range while you drive downhill.

Use the same travel speed on a downgrade and on an upgrade.

When you travel for any distance, keep the stick inward and carry the boom in a low position.

When you drive up a steep grade, keep the boom as close to the ground as possible.

When you travel uphill or you travel downhill, keep the boom on the uphill side of the machine.

1. Adjust the operator seat.
2. Fasten the seat belt.

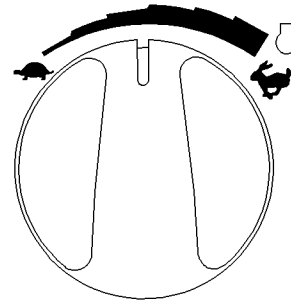

Illustration 218

g00732198

3. Turn the engine speed dial to the operating range.
4. Move the hydraulic lockout control to the UNLOCKED position.

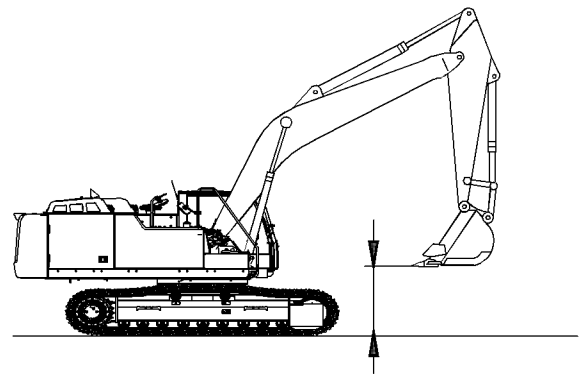

Illustration 219

g02145475

5. Raise the boom enough in order to provide sufficient ground clearance.

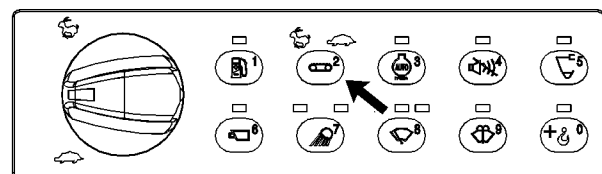

Illustration 220

g03262356

6. Select the desired travel speed by operating the travel speed control switch.

7. Make sure that the position of the upper structure and of the undercarriage is known before you move the machine. The drive sprockets should be at the rear of the machine.

Note: The directional steering controls will operate normally if the drive sprockets are at the rear of the machine and the idlers are at the front of the machine and under the cab. When the sprockets are under the cab, the travel controls will operate backward.

8. Turn the engine speed dial in order to increase the engine speed (rpm) to the desired speed.
9. Push both travel levers forward at the same time in order to travel forward. If both travel levers are pushed farther, the travel speed at the selected engine speed (rpm) will be faster.

Note: If the machine does not operate or if the machine does not travel in a straight line, consult your Caterpillar dealer.

10. See Operation and Maintenance Manual, "Operator Controls" for information about spot turning and about pivot turns.
11. When you make turns in soft material, travel in a forward direction occasionally in order to clear the tracks.
12. Slowly move both of the travel levers or both of the travel pedals to the CENTER position in order to stop the machine.

Lifting Objects

If the machine is equipped with the CE plate per requirements for the European Union, used to lift objects, then the machine must be equipped with the optional boom lowering control valve and an overload warning device.

A fit for purpose test was completed in order to confirm that a properly equipped machine meets the requirements of the European Union Machinery Directive "2006/42/EC" for lifting objects.

The overload warning device (if equipped) must be adjusted for the bucket linkage and bucket size that is installed on the machine. Adjust the overload warning device for proper operation.

The setting for the overload warning device (if equipped) should be checked by an authorized dealer.

i00059294

Frozen Ground Conditions

SMCS Code: 7000

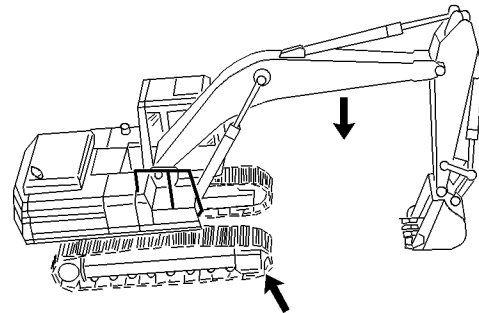

Illustration 221

g00101468

To free the tracks from frozen ground, swing the boom to the front of the machine. Use boom down pressure to free the idler end of the machine.

Swing the boom to the rear of the machine. Use boom down pressure to free the sprocket end of the machine.

i07162711

Equipment Lowering with Engine Stopped

SMCS Code: 7000

To lower the boom, place the hydraulic lockout lever in the UNLOCKED position. Move the joystick to the BOOM LOWER position. If the accumulator is still charged, the boom will lower.

If the boom does not lower, the accumulator is empty. Use one of the following methods to lower the boom.

Machine without a Boom Lowering Control Valve

WARNING

Be sure no one is under or near the work tools before manually lowering the boom. Keep all personnel away from the boom drop area when lowering the boom with the engine stopped in order to avoid possible personal injury.

When you must manually lower the boom due to engine shutdown, use the following procedure.

Note: Keep all personnel away from the boom when you are lowering the boom.

Relieve the pressure in the hydraulic system before manually lowering the boom. Move the hydraulic lockout lever to the UNLOCKED position. Move the travel levers/pedals forward and backward to relieve the pressure.

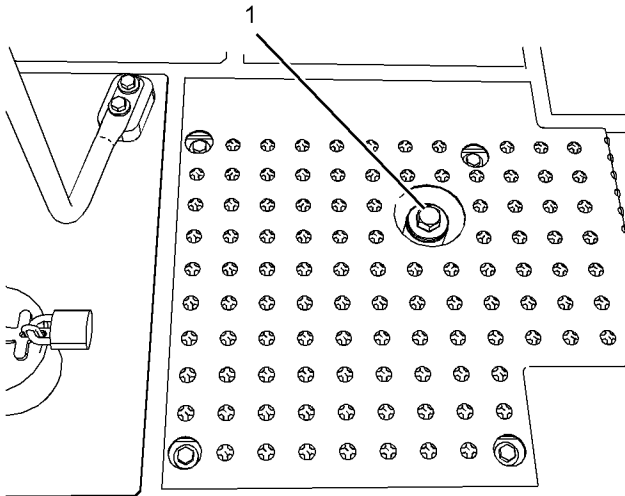

Illustration 222 g01356459
(1) Fill/vent plug

1. Slowly loosen fill/vent plug (1) on the top of the hydraulic tank until internal pressure in the hydraulic tank has been relieved. Remove fill/vent plug (1).

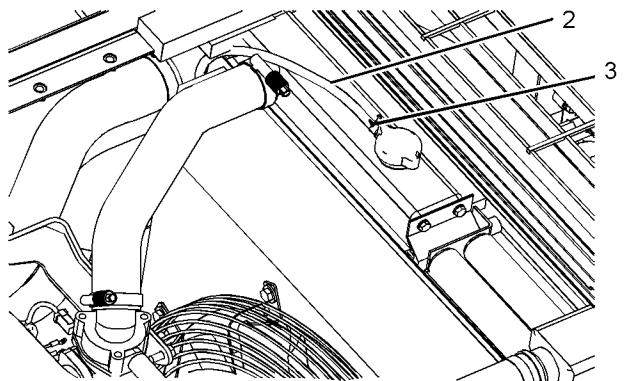

Illustration 223 g01220929
(2) Hose
(3) Clamp

2. Open the engine hood. Loosen clamp (3) and disconnect hose (2) from the radiator.

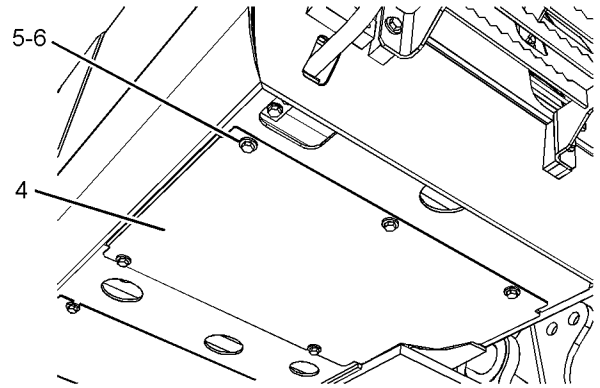

Illustration 224 g01221303
(4) Cover
(5) Bolts
(6) Washers

3. Remove cover (4), bolts(5) and washers (6).

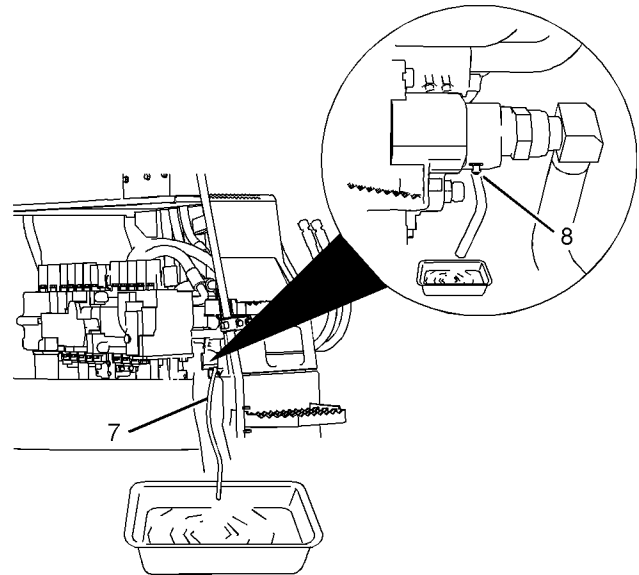

Illustration 225 g01362818
(7) Hose
(8) Screw

4. Put the other end of hose into a suitable container.

5. Slowly loosen screw (4) by a maximum of 1/2 turn. Loosening the screw allows the hydraulic oil in the boom circuit to drain into the container. The boom will now start to lower.

Note: Refer to Operation and Maintenance Manual, "General Hazard Information" for information on containing fluid spillage.

6. Make sure that the work tool has lowered all the way to the ground.
7. Connect hose (2) to the original position on the hydraulic tank and install the fill/vent plug securely.
8. Close the engine hood.

After completion of the manual boom lowering, make necessary repairs before you operate the machine again.

Note: For additional information, consult your Cat dealer.

Machine with a Boom Lowering Control Valve

WARNING

Boom load may cause cylinder oil pressure to reach relief pressure of the boom lowering control device when the boom is supported by one cylinder. Boom can lower suddenly, causing possible injury or death.

To avoid possible injury or death, be sure no one is under or near the work tool before manually lowering the boom.

Keep all personnel away from the boom drop area when lowering the boom with the engine stopped.

If the engine is shut down or the hydraulic system is disabled, the operator can still lower the boom. Use the following procedure if the machine is equipped with a boom lowering control valve.

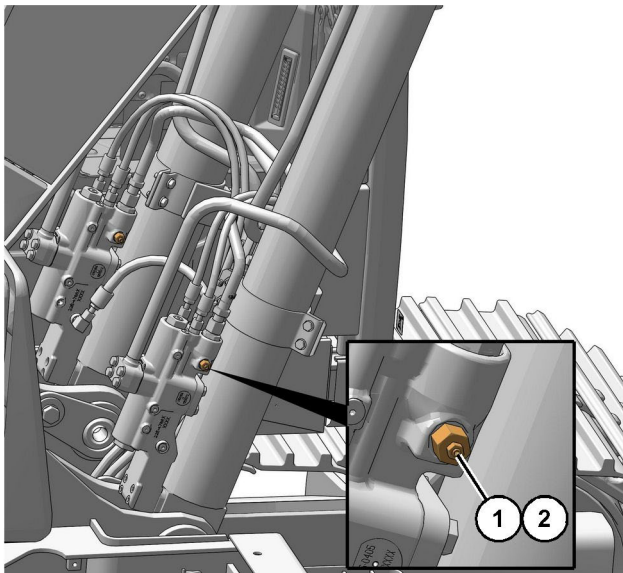

Illustration 226

g06235792

- (1) Locknut
(2) Check valve

The boom lowering control valve (if equipped) is installed on each of the boom cylinders. The boom lowering control valve allows the operator to lower the boom if the engine is stopped. The boom lowering control valve also prevents the sudden descent of the boom if there is an oil leak in the hydraulic line of the boom.

1. Loosen locknut (1) of the boom lowering check valve.
2. Slowly turn check valve (2) counterclockwise until the check valve stops. The boom will lower to the ground.
3. Make sure that the work tool has been lowered onto the ground. Tighten check valve (2).
4. Tighten check valve (2) to a torque of $2.25 \pm 0.25 \text{ N}\cdot\text{m}$ ($20.0 \pm 2.21 \text{ lb in}$).
Tighten locknut (1) to a torque of $4.0 \pm 0.5 \text{ N}\cdot\text{m}$ ($35.4 \pm 4.4 \text{ lb in}$).
5. Before operating the machine, make any necessary repairs.

For additional information, consult your Cat dealer.

Blade (If Equipped)

To lower the blade, place the hydraulic lockout control in the UNLOCKED position. Move the blade control lever to the BLADE LOWER position. If the accumulator is still charged, the blade will lower.

If the blade does not lower, the accumulator is empty. The blade will need to be blocked in the raised position until the engine can be started again.

More instructions can be found in the service manual and/or consult your Cat dealer.

Pressure Release of Auxiliary Lines

WARNING

Personal injury can result from hot oil spray and raised work tools.

Make sure all the work tools have been lowered, the oil is cool and the pressure has been released from the hydraulic system before removing any components or lines.

Do not allow hot oil or components to contact skin.

Note: Refer to Operation and Maintenance, "General Hazard Information" for information on containing fluid spillage.

Refer to the procedure below before any of the following conditions.

- The work tool is changed.
 - The position of the ball valve is changed.
1. Turn the engine start switch to the OFF position.
 2. Place the hydraulic lockout lever to ON position.
 3. Release the pressure in the auxiliary lines by pressing the auxiliary control buttons or the auxiliary control pedal three times.
 4. Place the hydraulic lockout lever in the OFF position.
 5. Change the work tool.

Note: There should be movement in the auxiliary hydraulic lines as the pressure is released. If there is no movement in the auxiliary hydraulic lines, start the engine and run the engine for 20 seconds. Repeat steps 1 to 5.

For additional information, consult your Cat dealer.

Operating Techniques

i05125989

Operating Technique Information

SMCS Code: 7000

WARNING

Know the maximum height and the maximum reach of your machine. Serious injury or death by electrocution can occur if the machine or the work tools are not kept a safe distance from electrical power lines. Keep a distance of at least 3000 mm (118 inch) plus an additional 10 mm (0.4 inch) for each 1000 volts over 50000 volts.

For safety, one of the following may require a greater distance:

- Local codes
- State codes
- Requirements of the job site

NOTICE

When swinging into a ditch, do not use the ditch to stop the swinging motion. Inspect the machine for damage if the boom is swung into a bank or an object.

Repeated stopping by an object can cause structural damage if the boom is swung into a bank or an object.

With certain boom-stick-bucket combinations, the bucket or worktool can hit the cab and/or the front structure of the machine. Always check for interference when first operating a new bucket or a new work tool. Keep the bucket or work tool away from the cab and away from the front structure during operation.

Whenever the tracks of the machine raise off the ground while digging, lower the machine back to the ground smoothly. **DO NOT DROP OR CATCH IT WITH THE HYDRAULICS.** Damage to the machine can result.

With certain combinations of work tools, the third pedal can have different functions. Always check the function of the third pedal before you use the third pedal.

Know the location of any buried cables. Mark the locations clearly before you dig.

Consult your Caterpillar dealer for special work tool tips that are available for use in severe applications.

Move the machine whenever the position for operating the machine is not efficient. The machine can be moved forward or backward during the operating cycle.

When you operate the machine in close places, utilize the bucket or the other work tool in order to perform the following functions:

- Pushing the machine
- Pulling the machine
- Lifting the tracks

Use a comfortable travel speed while you operate the machine.

Operating efficiency can be increased by using more than one machine control to perform a task.

Never swing a load over a truck cab or workers.

Position the truck so that material can be loaded from the rear of the truck or from the side of the truck. Load the truck evenly so that the rear axles are not overloaded.

An oversize bucket or a bucket that is equipped with side cutters should not be used in rocky material. These types of buckets slow down the cycle. Damage to the bucket and to other machine components could result.

Restricted Operation

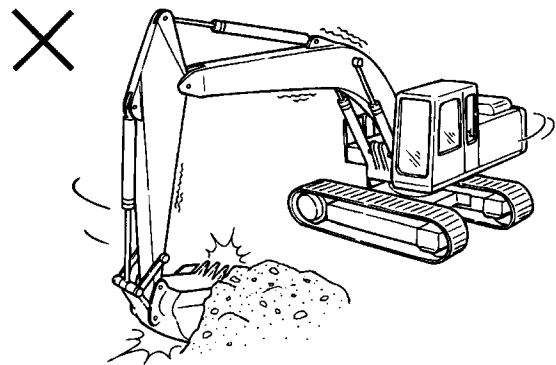

Illustration 227

g00529436

Do not use the swing force to perform the following operations:

- Soil compaction
- Ground breaking
- Demolition

Do not swing the machine while the bucket tips are in the soil.

These operations will damage the boom, the stick, and the work tool and the operations will reduce the life of the equipment.

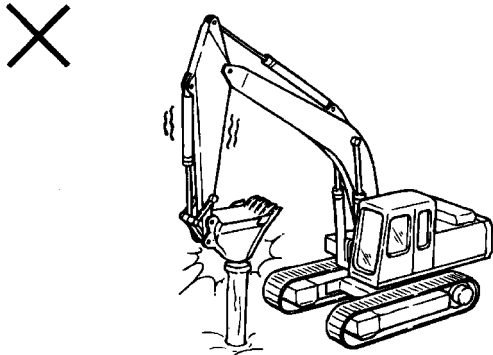

Illustration 228

g00529457

Do not use the dropping force of the bucket or work tool as a hammer. This will bring excessive force on the rear of the machine. Possible damage to the machine could result.

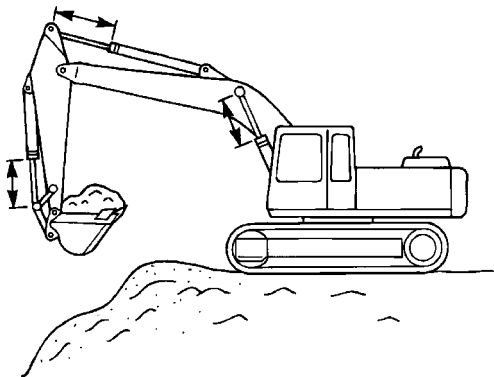

Illustration 229

g00529458

If the cylinder is operated at the end of the stroke during operations, excessive force will occur on the stopper on the inside of the cylinder. This will reduce the life of the cylinder and structures. To avoid this problem, always leave a small margin of play when the cylinder is operated.

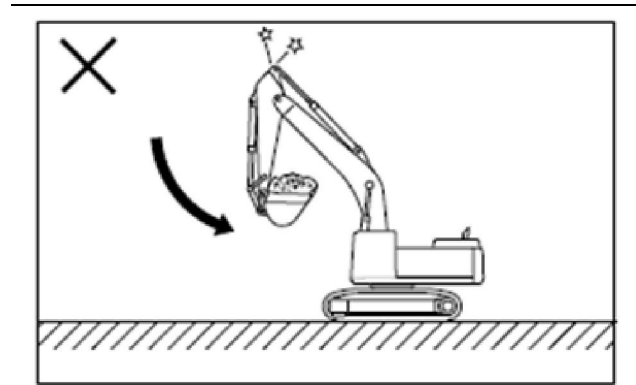

Illustration 230

g03286378

If the stick IN function is operated at full speed with a fully loaded bucket or heavy work tool attachment to the end of the cylinder stroke, excessive force will occur inside the stick cylinder. This action will reduce the life of the stick cylinder. To avoid this problem, always operate a stick IN function with moderate speed towards the end of cylinder stroke.

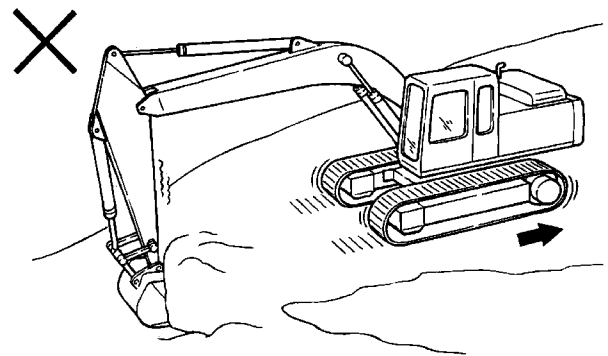

Illustration 231

g00529459

While the bucket is in the ground, do not use the travel force for any excavation. This operation will cause excessive force on the rear of the machine.

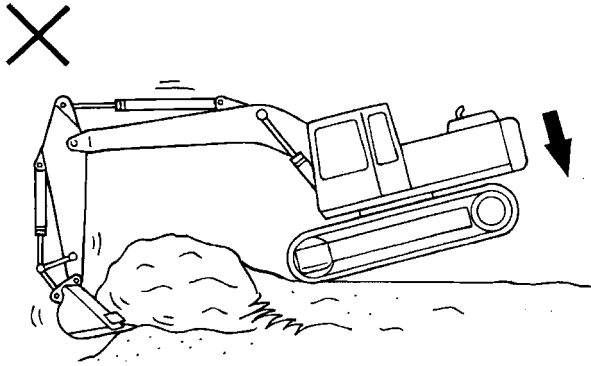

Illustration 232

g00529460

Do not use the dropping force of the rear of the machine for excavation. This operation will damage the machine.

Operating Precaution

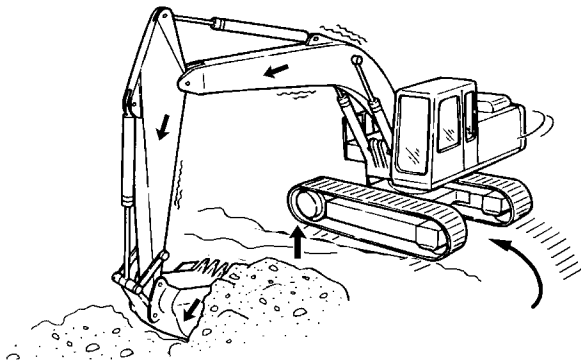

Illustration 233

g01250228

NOTICE

Do not allow the machine to swing from the force of traveling when you use the bucket, the stick, or the boom to assist in travel. If the force from traveling causes the machine to swing, damage may occur to the swing motor and to the swing drive.

Do not use the force of the bucket, the stick, or the boom to assist in turning the machine while the machine is traveling. This technique is referred to as "jump steering". This technique will damage the swing motor and the swing brake.

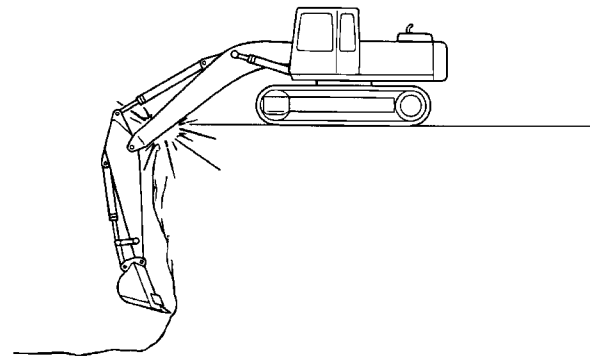

Illustration 234

g00529462

When deep holes are dug, do not lower the boom so that the bottom side of the boom touches the ground.

When deep holes are dug, do not allow the boom to interfere with the tracks.

i05032265

Travel in Water and Mud

SMCS Code: 7000-V6

NOTICE

When working in or around any body of water, around a stream or river, or in conditions of heavy mud, be careful that the swing bearing, the swing drive gear, and the swivel joint do not dip into water, mud, sand, or gravel. If the swing bearing dips into water, mud, sand, or gravel, immediately grease the swing bearing until the used grease leaks from the outer circle of the swing bearing. Failure to carry out this procedure may cause premature wear in the swing bearing.

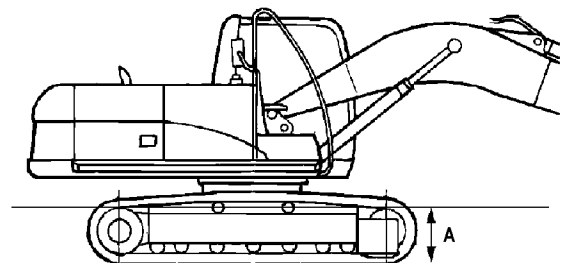

Illustration 235

g00807842

Depth of water to the center of the track carrier roller

The following guidelines pertain to travel across water and travel through mud, sand, or gravel.

The machine can travel across a river only under the following conditions:

- The bed of the river is flat.
- The flow of the river is slow.
- The machine dips into the water only to the center of the track carrier roller (dimension A).

NOTICE

Do not allow the fan on the engine to contact the water while the machine travels through the water. Do not allow the fan on the engine to contact the water during a swing while the machine is in the water. Damage to the fan may occur if the fan contacts the water.

While you cross the river, carefully confirm the depth of the water with the bucket. Do not move the machine into an area that has a water depth that is greater than Dimension A.

The machine may sink gradually on soft ground. Therefore, you should frequently check the height of the undercarriage from ground level and the depth of water on the ground.

Check the swing gear by looking through the port for inspection that is on the upper frame. If there is water in the swing gear, contact your Cat dealer for the required maintenance on the swing gear.

After you travel through water, carefully clean the machine in order to remove any salt, sand, or other foreign matter.

Procedure for Removing the Machine from Water or Mud

NOTICE

Do not allow the machine to swing from the force of traveling when you use the bucket, the stick, or the boom to assist in travel. If the force from traveling causes the machine to swing, damage may occur to the swing motor and to the swing drive.

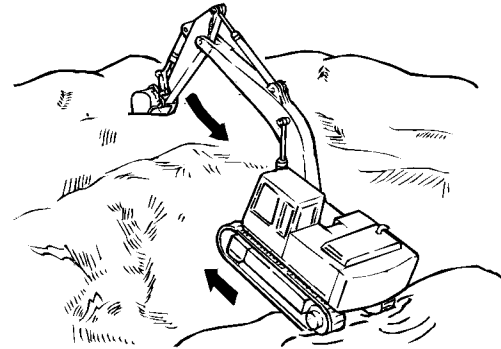

Illustration 236

g00808148

1. You may not be able to move the machine by using the travel controls only. In this case use both the travel control levers/pedals and the stick to pull the machine out of the water or ground.

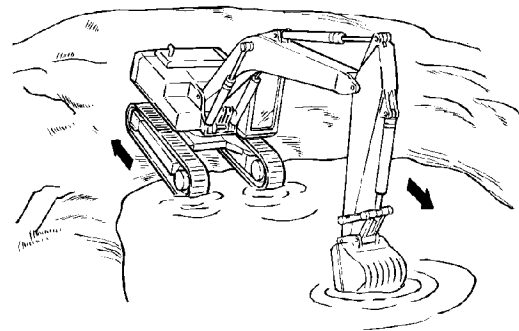

Illustration 237

g00808151

2. The machine may slip because of a steep slope. The procedure in Step 1 may not work. In this case, first rotate the upper structure by 180°. Then use both the travel control levers/pedals and the stick to move the machine up the slope.

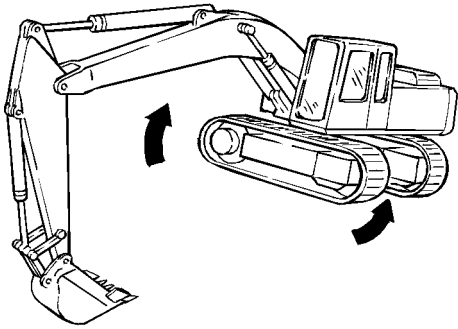

Illustration 238

g00808152

3. It may be impossible to travel because the bottom of the frame comes into contact with the ground or the undercarriage is clogged with mud or gravel. In this case, operate the boom and the stick together. Raise the track and rotate the track forward and backward in order to remove the mud and the gravel.

i05150572

Boom, Stick and Bucket Operation

SMCS Code: 7000

Digging

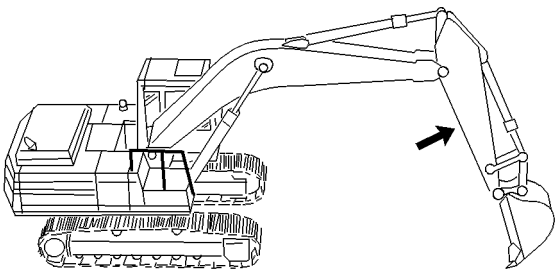

Illustration 239

g00101523

1. Position the stick at a 70 degree angle to the ground.

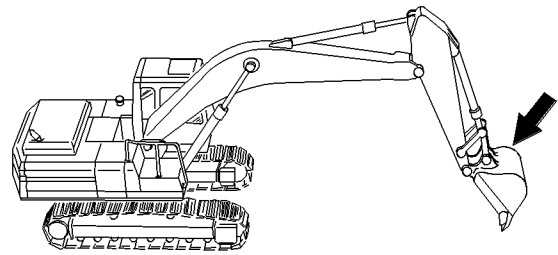

Illustration 240

g00101525

2. Position the bucket cutting edge at a 120 degree angle to the ground. Maximum breakout force can now be exerted with the bucket.

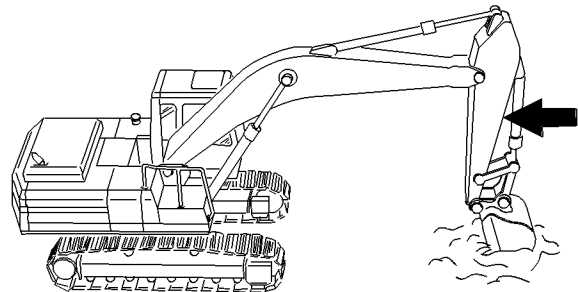

Illustration 241

g00101526

3. Move the stick toward the cab and keep the bucket parallel to the ground.

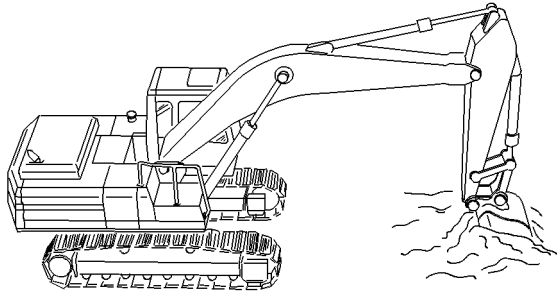

Illustration 242

g00101527

4. If the stick stops due to the load, raise the boom and/or perform a curl in order to adjust the depth of the cut.
5. To apply the greatest force at the cutting edge, decrease the down pressure as you move the stick toward the cab.
6. Maintain a bucket attitude that ensures a continuous flow of material into the bucket.
7. Continue the pass in a horizontal direction so that material peels into the bucket.

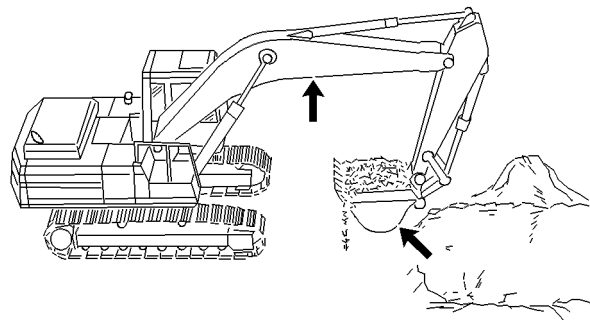

Illustration 243

g00101528

8. Close the bucket and raise the boom when the pass has been completed.

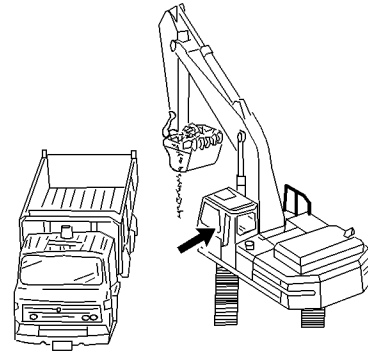

Illustration 244

g00101529

9. Engage the swing control when the bucket is clear of the excavation.

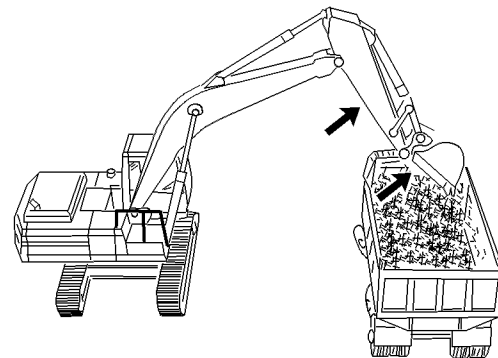

Illustration 245

g00101530

10. To dump a load, move the stick outward and open the bucket in a smooth motion.

Lifting Objects

WARNING

To prevent injury, do not exceed the rated load capacity of the machine. If the machine is not on level ground, load capacities will vary.

NOTICE

Damage to bucket cylinder, bucket or linkage could result if slings are placed incorrectly.

There may be local regulations and/or government regulations that govern the use of machines which lift heavy objects. Obey all local and government regulations.

Operation Section
Boom, Stick and Bucket Operation

If this machine is used to lift objects within an area that is controlled by the European Directive "2006/42/EC", the machine must be equipped with a boom lowering control valve, a stick lowering control valve, and an overload warning device.

Japan regulations require some machines to use a shovel crane configuration in order to lift certain objects.

Contact your Cat dealer for additional information.

Short slings will prevent excessive load swing.

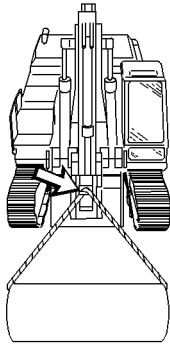

Illustration 246

g00101531

Use the lifting eye that is provided on the linkage to lift objects.

If the lifting eye is used, the connection must be made with a sling or with a shackle.

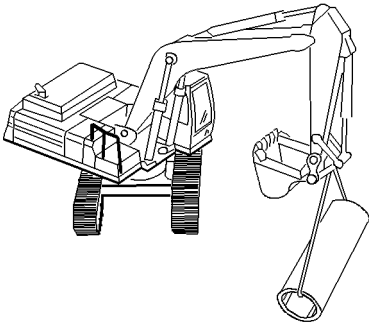

Illustration 247

g00101532

An unstable condition can exist if a load exceeds the machine load rating or if a heavy load is swung over an end or over a side.

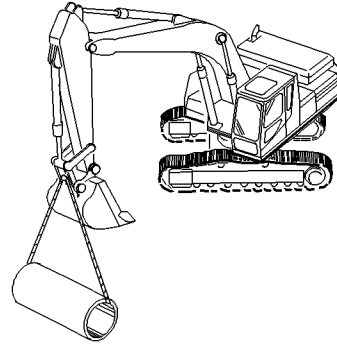

Illustration 248

g00101533

The most stable lifting position is over a corner of the machine.

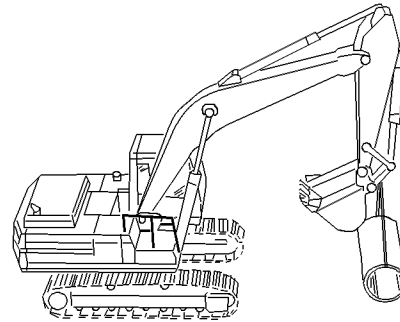

Illustration 249

g00101534

For the best stability, carry a load close to the machine and to the ground.

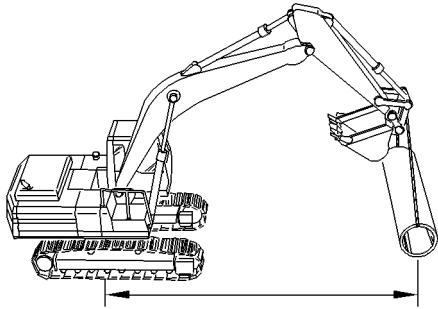

Illustration 250

g00101535

Lift capacity decreases as the distance from the swing centerline is increased.

Machines that are Equipped with a Long Reach Configuration

Machines with a long reach configuration require larger swing drift than standard machines when stopping, because inertial force in time of swing is large. Taking this into account, adjustments are made in timing for applying the swing brakes and speed of swinging.

Machines with a long reach configuration could be damaged and stability of the machine would be adversely affected if a control was suddenly operated, because inertial force of work tool is large.

i03875131

SmartBoom Operation (If Equipped)

SMCS Code: 5461-ZS; 7332

! WARNING

Personal injury or death can result from not following the proper procedures.

To avoid the possibility of injury or death, follow the established procedure.

! WARNING

Activating the SmartBoom function and using the work tool joystick control while the front of the machine is elevated could result in unexpected machine motion. Unexpected machine motion could result in serious injury or death. Do not activate the SmartBoom function if the front of the machine is elevated by the front linkage.

! WARNING

Do not elevate or lower the track when in the SmartBoom mode. Follow the operation procedures for the SmartBoom in the Operation and Maintenance Manual. Failure to follow these instructions can result in serious injury or death.

! WARNING

Always make sure that the boom control joystick is in the NEUTRAL position before activating the SmartBoom control. Activating the SmartBoom control with the joystick out of the neutral position could result in unexpected machine motion which could result in serious injury or death.

! WARNING

Do not select any SmartBoom mode, using the SmartBoom selector switch located on the console, while the tracks are elevated. Selecting the SmartBoom mode with the tracks elevated could result in a sudden drop of the machine which could result in serious injury or death.

! WARNING

If any SmartBoom mode is active and the boom control joystick is in the BOOM DOWN position (forward) with a bucket or a work tool on the ground, pressing the disable button that is located on the front of the right hand joystick could cause a sudden boom down motion. This control function could lift the machine upward, with unexpected machine movement that could result in serious injury or death. Do not press the disable button while the SmartBoom mode is active and the boom control joystick is in the BOOM DOWN position (forward) with a bucket or a work tool on the ground.

! WARNING

Do not attempt to lift the tracks of the machine by using the disable button and applying downward force with the boom lowering control while the machine is in any SmartBoom mode. Releasing the disable button will immediately return the machine to the active SmartBoom mode. This action could cause the machine to drop down abruptly which could result in serious injury or death.

The Caterpillar SmartBoom provides significant advantages in the following operations:

Excavation and Loading

The operator should select the SmartBoom UP AND DOWN mode for excavating operations and for loading operations. This mode is effective during the return cycle. The BOOM DOWN movement is assisted by gravity, and the pump flow that is normally required for the boom circuit is available for faster STICK OUT and SWING functions. More work is performed for the amount of hydraulic oil flow that is provided by the pumps. This results in faster cycle times and improved fuel efficiency.

When the SmartBoom UP AND DOWN mode is active, no downward hydraulic force is applied to the boom. The operator can intermittently apply downward hydraulic force when the force is required for bucket penetration. A button on the right joystick enables the operator to override the SmartBoom mode.

Hammering

The operator should select the SmartBoom DOWN mode for hammering operations. In the SmartBoom DOWN mode, the weight of the hammer plus the boom and the stick provides sufficient downward force for effective hammering. This mode prevents the hammer from rebounding. The boom follows the hammer downward freely as the tool penetrates the rock. This mode also reduces strain on the machine structures.

Advantages

In hammering, the SmartBoom provides the following advantages:

- The mode reduces shock in the cab.
- The mode reduces strain on machine structures.
- The mode prevents blank shots.
- The mode maintains optimum frequency.

In rock cleaning, the SmartBoom provides the following advantages:

- The mode reduces strain on machine structures.
- The mode reduces wear on the bucket and the teeth.
- The mode maintains optimum frequency.

In a leveling operation, the SmartBoom eases the operation. Only STICK IN actuation and bucket actuation are required to level the surface.

In material handling, the SmartBoom reduces the chance of damage below the material.

i05068589

Quick Coupler Operation (Hydraulic Pin Grabber Quick Coupler (If Equipped))

SMCS Code: 6129; 6522; 7000

NOTICE

The Caterpillar Quick Coupler (Hydraulic Pin Grabber) is not designed to be used in applications where there is long exposure to excessive vibration. The vibration caused by extensive use of a hydraulic hammer as well as the added weight of certain demolition tools such as shears, crushers, and pulverizers may cause premature wear and decreased service life of the coupler.

Be sure to carefully inspect the coupler daily for cracks, bent components, wear, distressed welds, etc. when operating with any of the above work tools.

General Operation

The quick coupler is used to change work tools while the operator remains in the cab. The quick coupler can be used with a broad range of buckets and work tools. Each work tool must have a set of pins in order for the quick coupler to work properly.

The work tools are held onto the quick coupler by hydraulic pressure. If pressure is lost, a check valve in the hydraulic cylinder traps oil in the cylinder. In addition to the check valve, a blocking bar locks the work tools to the quick coupler. Ensure that the hydraulic system and the blocking bar are working properly before using the quick coupler.

A lifting eye is included on the quick coupler. Release the work tool from the quick coupler in order to use the lifting eye to pick up loads. In order to lift a load with the lifting eye, extend the bucket cylinder until the quick coupler is in a VERTICAL position. Do not exceed the rated load for the machine.

NOTICE

Once the work tool has been properly attached to the coupler, no loosening of the work tool should occur. Refer to the “Quick Coupler Installation and Removal” section of the quick coupler Operation and Maintenance Manual for additional information. If at any point after the proper attachment and back drag testing of the work tool, should the work tool then become loose or if the rear pin of the work tool detaches from the movable hook, stop work immediately and safely ground and detach the work tool. Consult your Cat dealer to inspect the coupler prior to putting the coupler back into service. This situation could indicate potential coupler damage that may not be readily visible to the customer or operator of the machine and coupler.

NOTICE

Inspection of the Center-Lock coupler is required after a failure of the primary engaging system or a miscoupling of the tool, causing the work tool to swing by the secondary lock. Contact your Cat dealer.

Refer to Special Instruction, REHS5676, “The Inspection Procedure for the Center-Lock Coupler” for the proper procedure.

Note: Machines operating hydromechanical work tools equipped with a Center-Lock Pin Grabber Coupler, the addition of a Hydromechanical Conversion Kit may also be required. Refer to the Operation and Maintenance Manual for the quick coupler for more information or consult your Cat dealer.

Quick Coupler Operation

Description of the Instruction Film

An instruction film is included with the quick coupler. The instruction film illustrates the operation of the quick coupler.

Note: For detailed instructions on the operation of the quick coupler, refer to “Coupling the Work Tool” and “Uncoupling the Work Tool”.

The instruction film should be legible at all times. Clean the film or replace the film if the film is not legible. When you clean the film, use a cloth, water, and soap. Do not use solvent, gasoline, or harsh chemicals to clean the film. Solvents, gasoline, or harsh chemicals could loosen the adhesive that secures the film. Loose adhesive will allow the film to fall. If the film is damaged or the film is missing, replace the film. For more information, consult your Cat dealer.

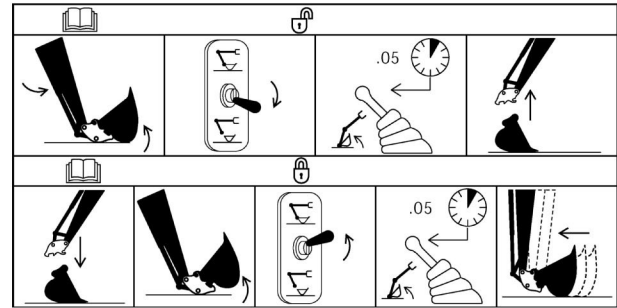

Illustration 251

g01231702

Instruction film

Description of the Top Frame on the Film (Uncoupling the Work Tool)

1. Extend the stick cylinder and extend the bucket cylinder until the work tool is curled past a vertical position.
2. Move the electric switch to the UNLOCK position.
3. Hold the control lever for the bucket cylinder in the EXTEND position for 5 seconds after the electric switch has been unlocked.
4. Place the work tool in the storage position close to the ground. Retract the bucket cylinder until the tool is disengaged from the quick coupler.

Description of the Bottom Frame on the Film (Coupling the Work Tool)

1. Engage the quick coupler onto the work tool.
2. Extend the stick cylinder and extend the bucket cylinder until the work tool is curled past a vertical position.
3. Move the electric switch to the LOCK position.
4. Hold the control lever for the bucket cylinder in the EXTEND position for 5 seconds after the electric switch has been locked.
5. Make sure that the quick coupler pins are engaged. Retract the bucket cylinder and drag the attachment on the ground. This method will ensure that the quick coupler pins are engaged.

WARNING

Crush injury. Could cause serious injury or death. Always confirm that the quick coupler is engaged onto the pins. Read the Operator's Manual.

Operation Section
Hydraulic Pin Grabber Quick Coupler (If Equipped)

NOTICE

Back drag the work tool on the ground to ensure the quick coupler is properly locked.

Do Not strike the work tool on the ground to ensure the quick coupler is properly locked. Striking the work tool on the ground will result in damage to the coupler cylinder.

Electric Switch Operation

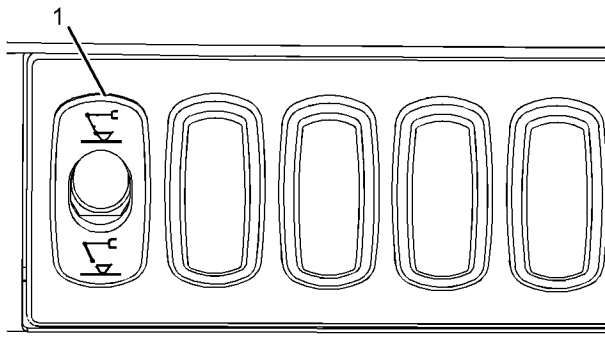

Illustration 252

g01354192

The electric switch (1) is located inside the cab. The electric switch has two positions that are used for coupling the work tool and uncoupling the work tool. Examples of the early switch type and the later switch type have been shown above. Refer to this Operation and Maintenance Manual, "Operator Controls" for the location of the electric switch.



UNLOCK – In order to unlock the coupler, extend the stick cylinder and extend the bucket

cylinder until the bucket is fully curled under the stick. Pull the switch outward and move the switch toward the UNLOCK position. A buzzer will sound. Hold the control lever for the bucket cylinder in the EXTEND position for 5 seconds after the electric switch has been unlocked. The switch must remain in the UNLOCK position until another work tool is attached. The switch must remain in the UNLOCK position in order to prevent the blocking bar from jamming.



LOCK – In order to lock the coupler, engage the quick coupler onto the work tool.

Extend the stick cylinder and extend the bucket cylinder until the bucket is fully curled under the stick. Pull the switch outward and move the switch toward the LOCK position. Hold the control lever for the bucket cylinder in the EXTEND position for 5 seconds after the electric switch has been locked. Make sure that the quick coupler is engaged onto the pins. Retract the bucket cylinder and drag the attachment on the ground. This method will ensure that the quick coupler is engaged onto the pins.

Coupling the Work Tool

⚠ WARNING

Place the work tool or bucket in a safe position before engaging the quick coupler. Ensure that the work tool or bucket is not carrying a load.

Serious injury or death may result from engaging the work tool or bucket when it is in an unstable position or carrying a load.

⚠ WARNING

Inspect the quick coupler engagement before operating the machine.

Serious injury or death may result from improperly engaged coupler.

⚠ WARNING

Crush injury. Could cause serious injury or death. Always confirm that the quick coupler is engaged onto the pins. Read the Operator's Manual.

⚠ WARNING

The buzzer will not sound when the switch is in the lock position. The position of the switch does not confirm the coupler pins are engaged. A physical test is required by dragging the attachment on the ground to confirm the coupler pins are engaged.

NOTICE

With certain work tool combinations, including quick couplers, the work tool can hit the cab or the front of the machine. Always check for interference when first operating a new work tool.

1. Position the bucket or the work tool on a level surface.
2. Make sure that the pins are in the bucket or the work tool. Make sure that the pin keepers are installed correctly.

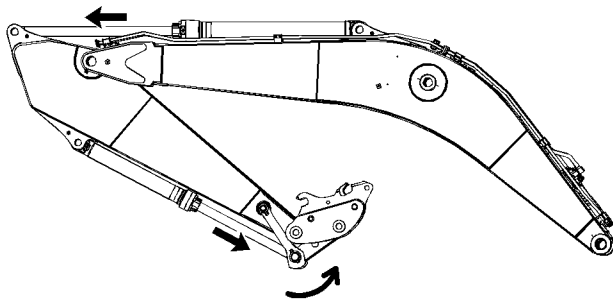

Illustration 253 g01231266

3. In order to prevent the blocking bar from jamming, the quick coupler must be curled past a vertical position before you move the switch from the LOCK position to the UNLOCK position. Extend the stick cylinder and extend the bucket cylinder until the quick coupler is curled past a vertical position.
4. Pull the switch outward and move the switch to the UNLOCK position. A buzzer will sound.

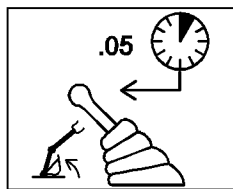

Illustration 254 g01231447

5. Hold the control lever for the bucket cylinder in the EXTEND position for 5 seconds after the electric switch has been unlocked. The switch must remain in the UNLOCK position until the work tool is attached in order to prevent the blocking bar from jamming. The buzzer will continue to sound until the switch is moved to the LOCK position.

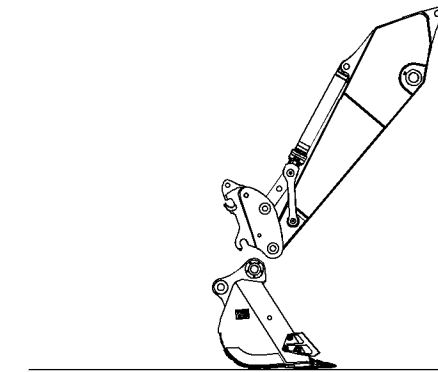

Illustration 255 g01231316

6. Align the quick coupler with the work tool.

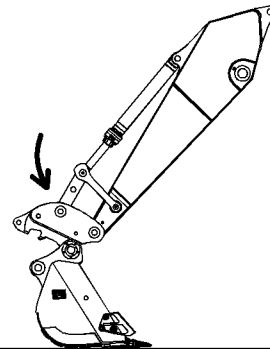

Illustration 256 g01231317

7. Rotate the quick coupler in order to grab the top pin.

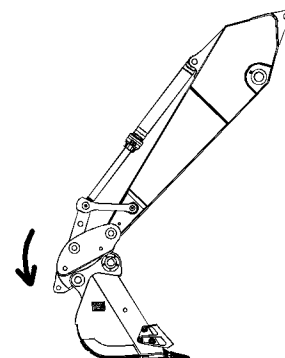

Illustration 257 g01231320

8. Rotate the quick coupler downward in order to grab the bottom pin.

Operation Section
Hydraulic Pin Grabber Quick Coupler (If Equipped)

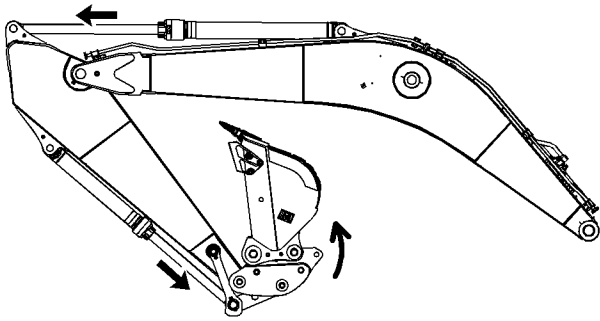

Illustration 258

g01231322

9. Extend the stick cylinder and extend the bucket cylinder until the work tool is curled past a vertical position. This must be performed before you move the switch from the UNLOCK position to the LOCK position.

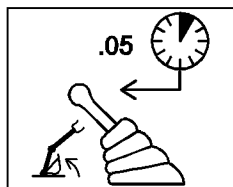

Illustration 259

g01231447

NOTICE

Hold the bucket cylinder control lever in the EXTEND position while the switch is moved into the LOCK position. Failure to do so may result in unwanted movement of the worktool.

10. Move the switch to the LOCK position. Hold the control lever for the bucket cylinder in the EXTEND position for 5 seconds in order to lock the hook.
11. The “Work Tool Select” menu will be displayed on the monitor system. Scroll through the menu in order to select the desired work tool. Refer to this Operation and Maintenance Manual, “Monitoring System” for more information.

⚠ WARNING

Crush injury. Could cause serious injury or death. Always confirm that the quick coupler is engaged onto the pins. Read the Operator's Manual.

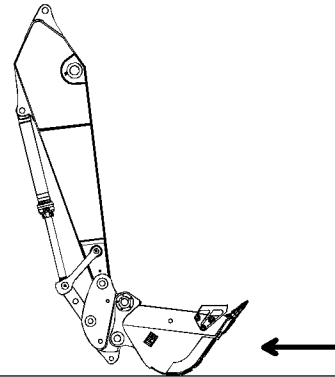

Illustration 260

g01231327

⚠ WARNING

Inspect the quick coupler engagement before operating the machine.

Verify that the quick coupler is engaged per the procedure in the Operation and Maintenance Manual. Verify prior to operating the machine, after every engine start, and after an extended time of inactivity.

Serious injury or death may result from improperly engaged coupler.

12. Verify that the quick coupler and the work tool are locked together.
- Retract the bucket cylinder and place the work tool on the ground.
 - Apply pressure to the work tool against the ground.
 - Drag the work tool backward.

NOTICE

Back drag the work tool on the ground to ensure the quick coupler is properly locked.

Do Not strike the work tool on the ground to ensure the quick coupler is properly locked. Striking the work tool on the ground will result in damage to the coupler cylinder.

Uncoupling the Work Tool

WARNING

Place the work tool or bucket in a safe position before disengaging the coupler. Disengaging the coupler will release the work tool or bucket from control of the operator.

Serious injury or death may result from disengaging the work tool or bucket when it is in an unstable position or carrying a load.

NOTICE

Auxiliary hoses for work tools must be disconnected before the quick coupler is disengaged.

Pulling the work tool with the auxiliary hoses could result in damage to the host machine or the work tool.

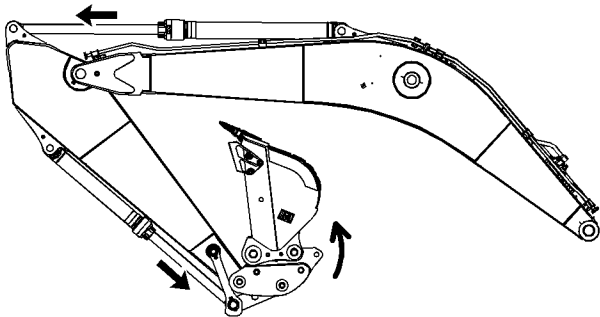

Illustration 261

g01231322

1. Extend the stick cylinder and extend the bucket cylinder until the work tool is curled past a vertical position. This must be performed before you move the switch from the LOCK position to the UNLOCK position.
2. Pull the switch outward and move the switch to the UNLOCK position.

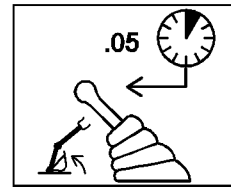

Illustration 262

g01231447

3. Hold the control lever for the bucket cylinder in the EXTEND position for 5 seconds in order to unlock the hook. A buzzer will sound until the switch is moved to the LOCK position. In order to lift objects with the lifting eye of the quick coupler, refer to "Coupler Lifting Eye Operation without Bucket".

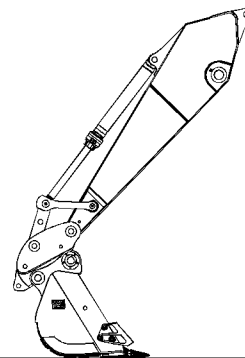

Illustration 263

g01231426

4. Move the boom and the stick until the tool or the bucket is in the storage position. Keep the tool close to the ground.

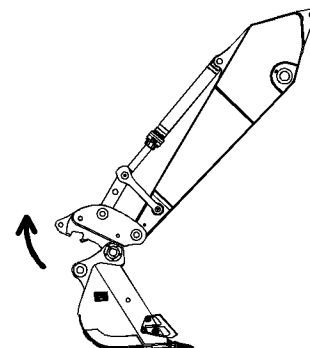

Illustration 264

g01231430

5. Rotate the quick coupler upward in order to release the bottom pin.

Operation Section
Hydraulic Pin Grabber Quick Coupler (If Equipped)

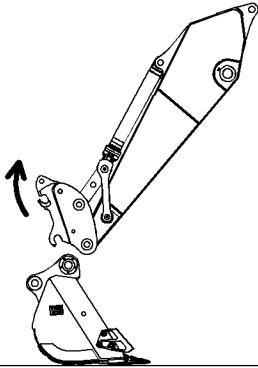

Illustration 265

g01231432

6. Continue to rotate the quick coupler upward in order to release the top pin and completely release the work tool from the quick coupler.
7. Move the stick to a position that is clear of the work tool.

Note: In order to lift objects with the lifting eye of the quick coupler, refer to “Coupler Lifting Eye Operation without Bucket”.

Coupling a Bucket that is Reversed

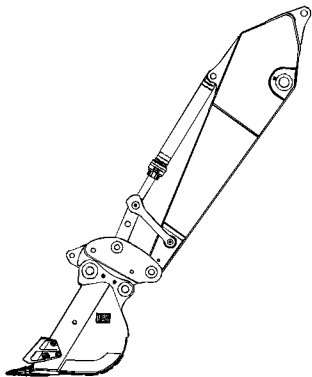

Illustration 266

g01231682

1. When you use a hydraulic pin grabber quick coupler, you can connect to a bucket that is in a reversed position. Refer to Illustration 266 for an example of connecting to a bucket that is in a reversed position.

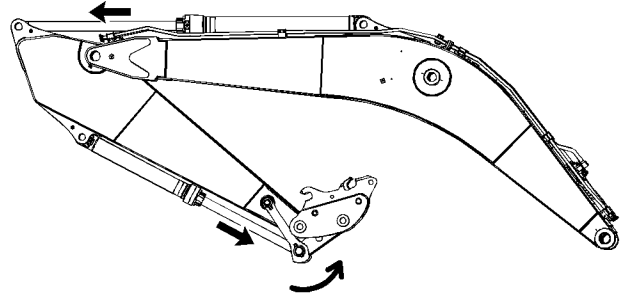

Illustration 267

g01231266

2. In order to prevent the blocking bar from jamming, the quick coupler must be curled past a vertical position before you move the switch from the LOCK position to the UNLOCK position. Extend the stick cylinder and extend the bucket cylinder until the quick coupler is curled past a vertical position.
3. Follow the same steps for coupling the work tool in order to couple the host machine to a bucket that is reversed. Refer to “Coupling the Work Tool” for the proper procedure.

NOTICE

When some Caterpillar buckets are used in the reverse position, it can be more difficult to couple the bucket and uncouple the bucket than in the normal position.

Care must be taken to ensure that the position of the boom, stick, and bucket are aligned to ensure smooth coupling. The coupler must be in position between the bucket bosses.

If the bucket is not fully engaged in the jaw of the coupler, the quick coupler can become snagged on the bucket bosses. The full weight of the bucket is then carried by the quick coupler sideplates, which can cause damage to the quick coupler.

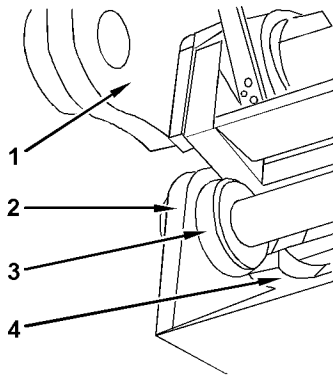

Illustration 268

g01231689

- (1) Quick coupler
- (2) Bucket
- (3) Boss
- (4) Hook

Coupler Lifting Eye Operation without Bucket

1. Remove the work tool. Refer to "Uncoupling the Work Tool" for the proper procedure.

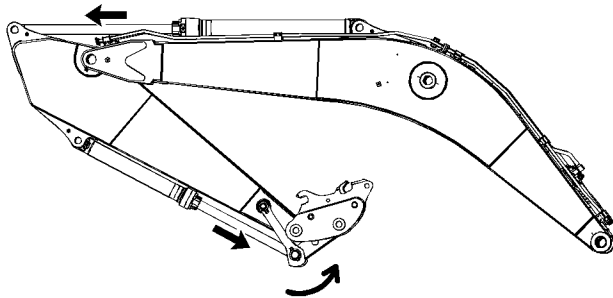

Illustration 269

g01231266

2. In order to prevent the blocking bar from jamming, the quick coupler must be curled past a vertical position before you move the switch from the UNLOCK position to the LOCK position. Extend the stick cylinder and extend the bucket cylinder until the quick coupler is curled past a vertical position.
3. Pull the switch outward and move the switch to the LOCK position. The buzzer will no longer sound.

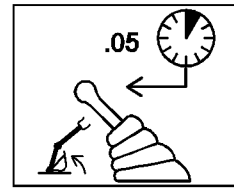

Illustration 270

g01231447

4. Hold the control lever for the bucket cylinder in the EXTEND position for 5 seconds after the electric switch has been locked.

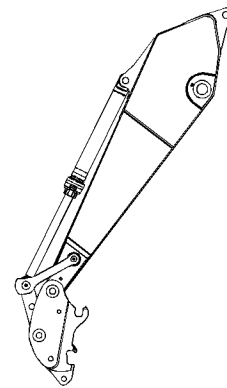

Illustration 271

g01231666

5. Rotate the quick coupler downward and move the stick to a position that is clear of the work tool.

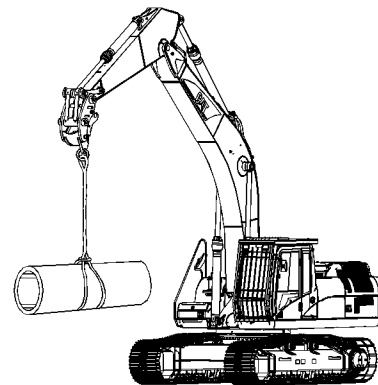

Illustration 272

g01187716

6. Use the lifting eye of the quick coupler, as needed.

- In order to reinstall the bucket or the work tool, refer to "Coupling the Work Tool" for the proper procedure.

i05944562

Quick Coupler Operation (Circuit for Universal Coupler (If Equipped))

SMCS Code: 6129; 6522; 7000

Operation

This procedure describes the use of the hydraulic circuit with a Caterpillar dedicated quick coupler. If a different quick coupler is used, please contact your Caterpillar dealer for pressure adjustment and consult the documentation for the quick coupler for proper operation.

- The engine start switch is on.
- The engine is running.
- The hydraulic lockout control must be in the UNLOCKED position in order to operate the quick coupler controls.
- During the operation, the alarm will sound.

When the above conditions are achieved, the system will perform the desired operation. A warning alarm will sound if the switch for the quick coupler is turned to the LOCKED position or the UNLOCKED position as long as the hydraulic lockout control is in the UNLOCKED position.

Resetting the Quick Coupler Controls

Operation of the quick coupler may be interrupted by deactivating the hydraulic lockout control. The quick coupler controls will be disabled. Use the following procedure to reset the quick coupler control.

- Return the quick coupler switch to the LOCKED position.
- Turn the engine start switch to the OFF position and then turn the engine start switch to the ON position.

- Move the hydraulic lockout control to the LOCKED position.

Securing the Work Tool

⚠ WARNING

Inspect the coupler wedge engagement before you operate the excavator.

Serious injury or death may result from an improperly engaged coupler.

Inspect coupler wedge engagement from the cab by rotating the bucket or the work tool inward. Extend the bucket cylinder to bring the coupler actuator into view and bring the stick in until the wedges are visible.

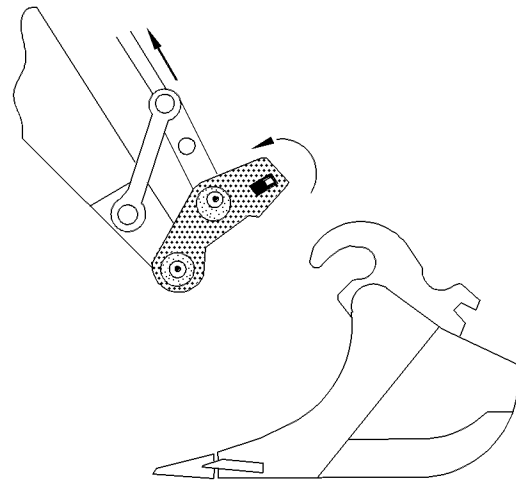

Illustration 273

g00104707

- Position the work tool on a level surface.
- Retract the bucket cylinder. Position the quick coupler in alignment between the hinges of the work tool.

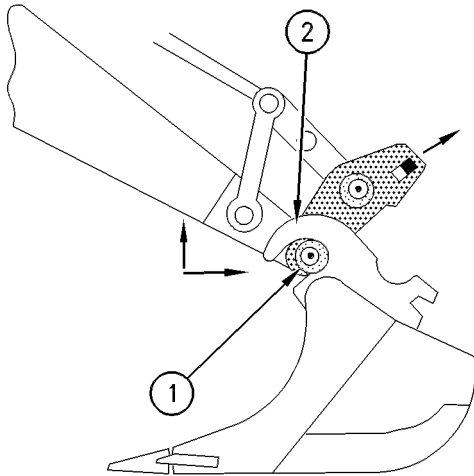

Illustration 274

g00104708

- (1) Lower bosses
- (2) Hinges

3. Move the stick forward and raise the stick until the lower bosses (1) engage the hinges (2) of the work tool.

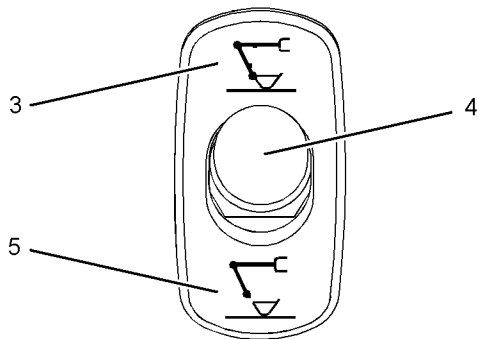

Illustration 275

g03733058

- (3) Locked
- (4) Quick coupler switch
- (5) Unlocked

4. Move the switch for the quick coupler to the UNLOCKED position in order to extend the wedge. Use this position only during the coupling or uncoupling of the work tool. The hydraulic system is pressurized for 10 seconds when the switch is in the UNLOCKED position.

Note: Whenever the switch is on the UNLOCKED position, a warning alarm will sound.

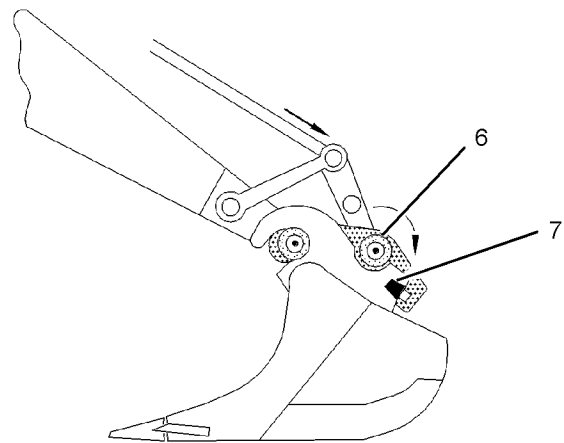

Illustration 276

g01620262

- (6) Center bosses
- (7) Locking area

5. Extend the bucket cylinder in order to rotate the quick coupler toward the work tool.

Center bosses (6) must engage with the cutout of the hinge.

6. Move the switch for the quick coupler to the LOCKED position in order to retract the wedge. The hydraulic system is pressurized for 10 seconds when the switch is in the UNLOCKED position.

The springs in the quick coupler will move the wedge into the locking area (7).

Note: The warning alarm will sound for 10 seconds.

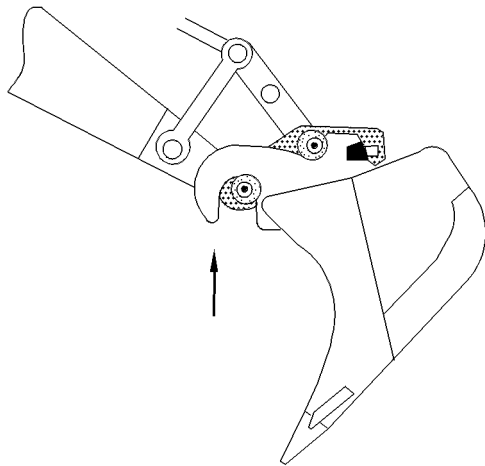

Illustration 277

g00104710

7. Raise the boom or raise the stick. Retract the bucket cylinder in order to confirm that the wedge is fully engaged. If the wedge is fully engaged, the work tool is locked in place. The work tool is ready to use.

Releasing the Work Tool

WARNING

Place the work tool or bucket in a safe position before disengaging the coupler. Disengaging the coupler will release the work tool or bucket from control of the operator.

Serious injury or death may result from disengaging the work tool or bucket when it is in an unstable position or carrying a load.

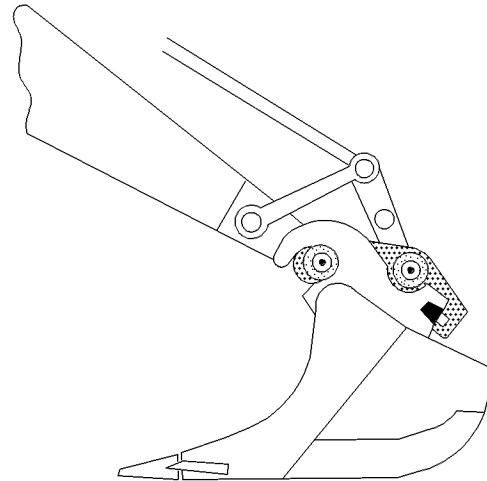

Illustration 278

g00104711

1. Level the bucket or level the work tool on the ground.
2. Move the switch for the quick coupler to the UNLOCKED position in order to extend the wedge. Use this position only during the coupling or uncoupling of the work tool. The hydraulic system is pressurized for 10 seconds when the switch is in the UNLOCKED position.

Note: The warning alarm will sound.

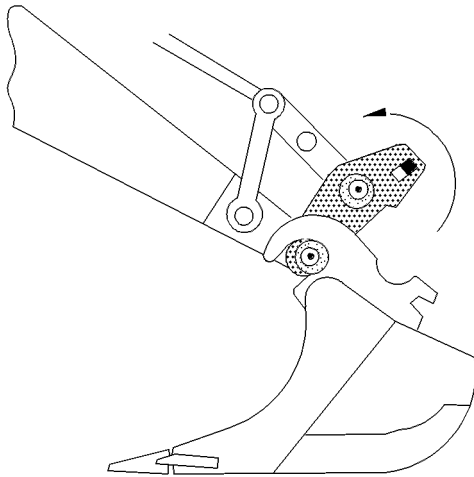

Illustration 279

g00104713

3. Retract the bucket cylinder in order to move the quick coupler toward the machine.
4. Move the switch for the quick coupler to the LOCKED position in order to retract the wedge.

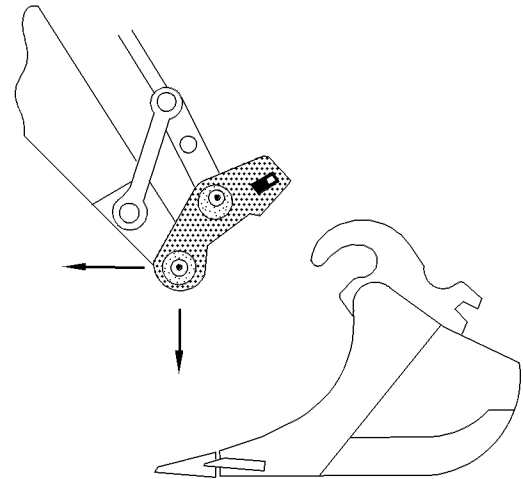

Illustration 280

g00104714

5. Lower the stick and move the stick toward the machine in order to disengage the quick coupler.

i06139647

Bucket - Remove and Install

SMCS Code: 6001-012; 6001-011; 6001; 6101; 6102; 6523

Captured Flag

WARNING

Failure to follow the instruction below for the installation of a work tool may result in personal injury or death. Special care must be taken if more than one person is installing the work tool.

- Confirm the verbal communication and the hand signals that will be used during the installation.
- Be alert for sudden movement of the front linkage and the work tool.
- Do not insert fingers into the bores of the support pins when the support pins and the bores are being aligned.

NOTICE

To facilitate removal of the bucket pins without causing damage to the pins, the bearings, and/or the O-ring seals put the bucket on the floor and the stick in a vertical position, as shown.

Removal Procedure

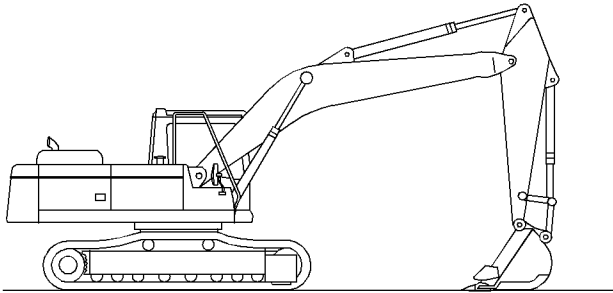

Illustration 281

g02154493

1. Start the engine. Park the machine on a hard, level surface. Position the bucket, the stick, and the bucket control linkage, as shown. Shut off the engine.

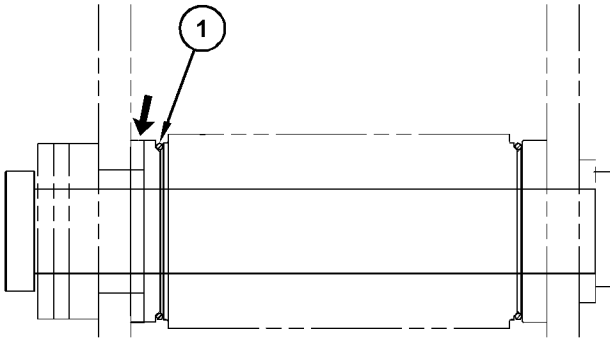

Illustration 282

g03822729

2. Slide O-ring seals (1) off the pin joints and onto the flanges of the bucket.

WARNING

When the pin assembly is removed, the linkage assembly may swing out of the bucket. To prevent possible personal injury, do not stand in front of the linkage assembly when the pin assembly is being removed.

Note: Removing the support pin may be difficult due to excessive pressure on the support pin. Remove the pressure on the support pin by adjusting the front linkage.

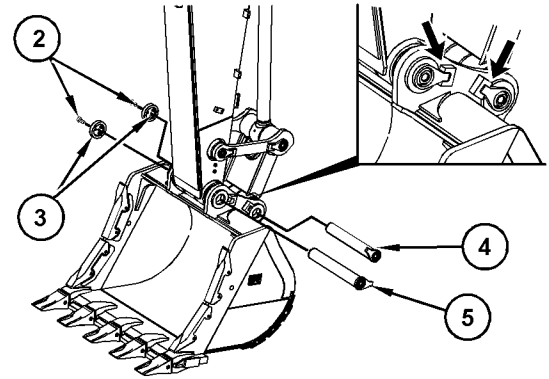

Illustration 283

g03822731

3. Remove bolts (2) and retaining plates (3). Then remove support pin (4) and support pin (5).
4. Start the engine and raise the stick out of the bucket.
5. Remove the O-ring seals (1) from the flanges on the bucket.

Note: After the support pins have been removed, make sure that the support pins do not become contaminated with sand or dirt. Make sure that the seals on the end of the stick and the seals on the end of the link do not become damaged.

Installation Procedure

1. Clean each pin and each pin bore. Lubricate each pin bore with molybdenum grease.

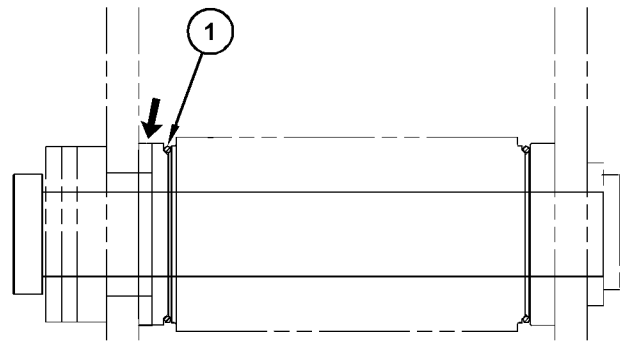

Illustration 284

g03822729

2. Position the O-ring seals (1) onto the flanges of the bucket.
3. Start the engine and lower the stick into the bucket until the pin bores are in alignment with each other. Stop the engine.

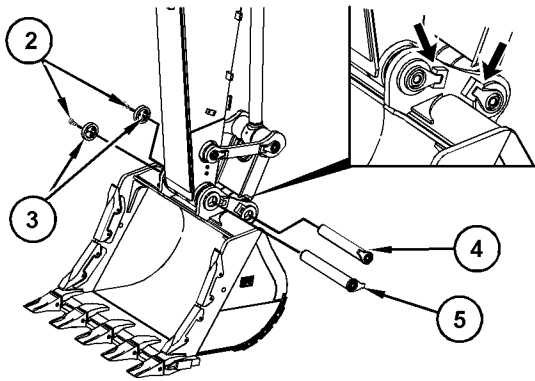

Illustration 285

g03822731

4. Insert support pin (5) into the pin bore. Make sure that the flange of the support pin rest inside the support on the side of the bucket.
5. Refer to Operation and Maintenance Manual, "Bucket Linkage - Inspect/Adjust" in order to adjust the bucket clearance.
6. Install retaining plate (3). Install bolts (2). Tighten bolts (2) evenly.
7. Slide O-ring seals (1) in position over the pin joints between the bucket and the stick.
8. Start the engine and position the bucket linkage into the bucket until the pin bores are in alignment with each other. Stop the engine.
9. Insert support pin (4) into the pin bore. Make sure that the flange of the support pin rest inside the support on the side of the bucket.
10. Install retaining plate (3). Install bolts (2). Tighten bolts (2) evenly.
11. Slide the O-ring seals (1) over the pin joints between the bucket and the link assembly.

12. Lubricate the bucket pins. Refer to Operation and Maintenance Manual, "Bucket Linkage - Lubricate" or Operation and Maintenance Manual, "Boom, Stick, and Bucket Linkage - Lubricate".

Bolted Flag

WARNING

Failure to follow the instruction below for the installation of a work tool may result in personal injury or death. Special care must be taken if more than one person is installing the work tool.

- Confirm the verbal communication and the hand signals that will be used during the installation.
- Be alert for sudden movement of the front linkage and the work tool.
- Do not insert fingers into the bores of the support pins when the support pins and the bores are being aligned.

NOTICE

To facilitate removal of the bucket pins without causing damage to the pins, the bearings, and/or the O-ring seals put the bucket on the floor and the stick in a vertical position, as shown.

Removal Procedure

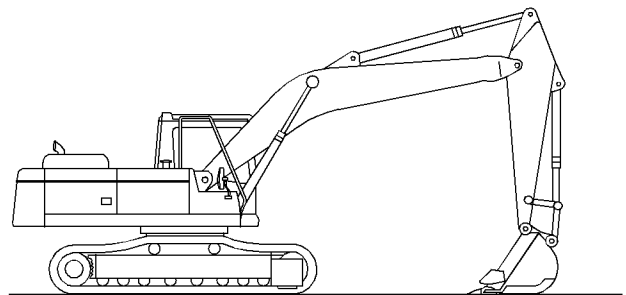

Illustration 286

g02154493

1. Start the engine. Park the machine on a hard, level surface. Position the bucket, the stick, and the bucket control linkage, as shown. Shut off the engine.

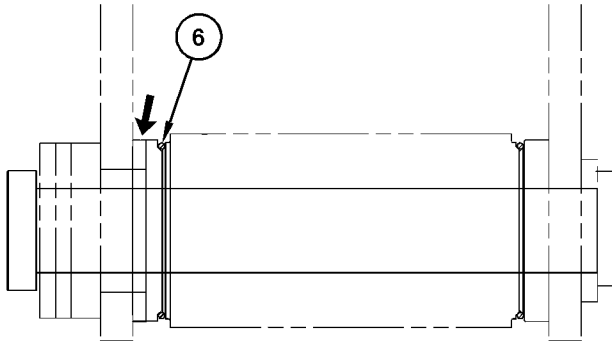

Illustration 287

g03822734

- Slide O-ring seals (6) off the pin joints and onto the flanges of the bucket.

WARNING

When the pin assembly is removed, the linkage assembly may swing out of the bucket. To prevent possible personal injury, do not stand in front of the linkage assembly when the pin assembly is being removed.

Note: Removing the support pin may be difficult due to excessive pressure on the support pin. Remove the pressure on the support pin by adjusting the front linkage.

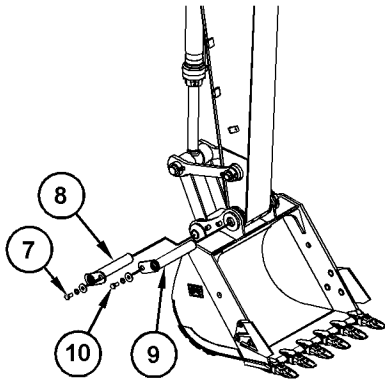

Illustration 288

g03822736

- Remove bolt (7). Remove support pin (8).
- Remove bolt (10). Remove support pin (9).
- Start the engine and raise the stick out of the bucket.
- Remove the O-ring seals (6) from the flanges on the bucket.

Note: After the support pins have been removed, make sure that the support pins do not become contaminated with sand or dirt. Make sure that the seals on the end of the stick and the seals on the end of the link do not become damaged.

Installation Procedure

- Clean each pin and each pin bore. Lubricate each pin bore with molybdenum grease.

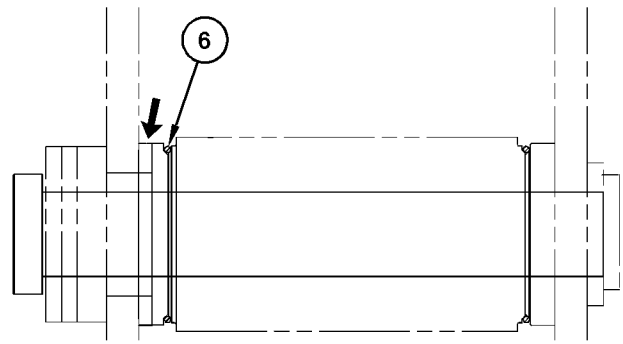

Illustration 289

g03822734

- Position the O-ring seals (6) onto the flanges of the bucket.

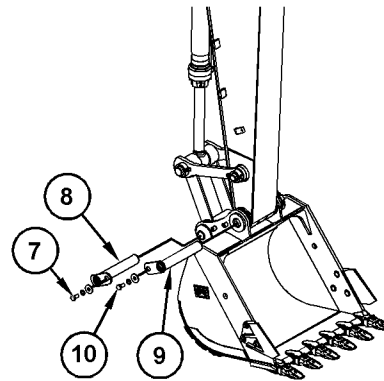

Illustration 290

g03822736

- Start the engine and lower the stick into the bucket until the pin bores are in alignment with each other. Stop the engine.
- Install support pin (9) into the pin bore.
- Install bolt (10).
- Refer to Operation and Maintenance Manual, "Bucket Linkage - Inspect/Adjust" in order to adjust the bucket clearance.
- Slide O-ring seals (6) in position over the pin joints between the bucket and the stick.

8. Start the engine and position the bucket linkage into the bucket until the pin bores are in alignment with each other. Stop the engine.
9. Install support pin (8) into the pin bore.
10. Install Bolt (7).
11. Slide the O-ring seals (6) over the pin joints between the bucket and the link assembly.
12. Lubricate the bucket pins. Refer to Operation and Maintenance Manual, "Bucket Linkage - Lubricate" or Operation and Maintenance Manual, "Boom, Stick, and Bucket Linkage - Lubricate".

Crossbolt

WARNING

Failure to follow the instruction below for the installation of a work tool may result in personal injury or death. Special care must be taken if more than one person is installing the work tool.

- Confirm the verbal communication and the hand signals that will be used during the installation.
- Be alert for sudden movement of the front linkage and the work tool.
- Do not insert fingers into the bores of the support pins when the support pins and the bores are being aligned.

NOTICE

To facilitate removal of the bucket pins without causing damage to the pins, the bearings, and/or the O-ring seals put the bucket on the floor and the stick in a vertical position, as shown.

Removal Procedure

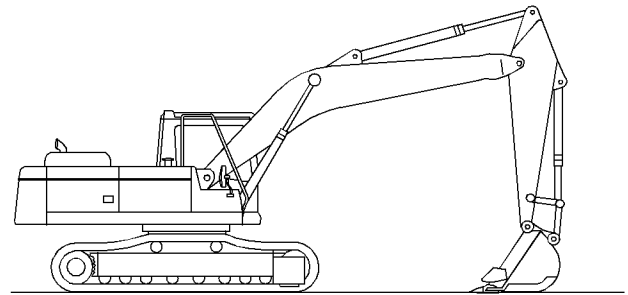

Illustration 291

g02154493

1. Start the engine. Park the machine on a hard, level surface. Position the bucket, the stick, and the bucket control linkage, as shown. Shut off the engine.

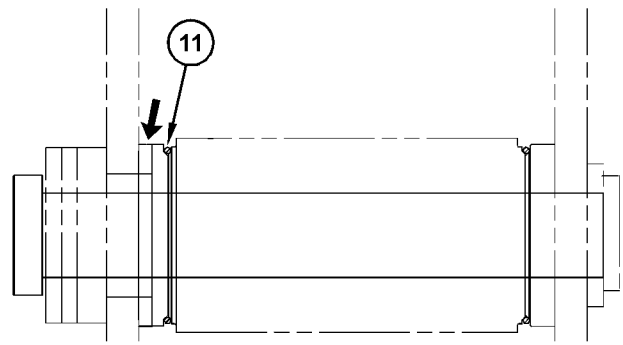

Illustration 292

g03822738

2. Slide O-ring seals (11) off the pin joints and onto the flanges of the bucket.

WARNING

When the pin assembly is removed, the linkage assembly may swing out of the bucket. To prevent possible personal injury, do not stand in front of the linkage assembly when the pin assembly is being removed.

Note: Removing the support pin may be difficult due to excessive pressure on the support pin. Remove the pressure on the support pin by adjusting the front linkage.

Operation Section
Bucket - Remove and Install

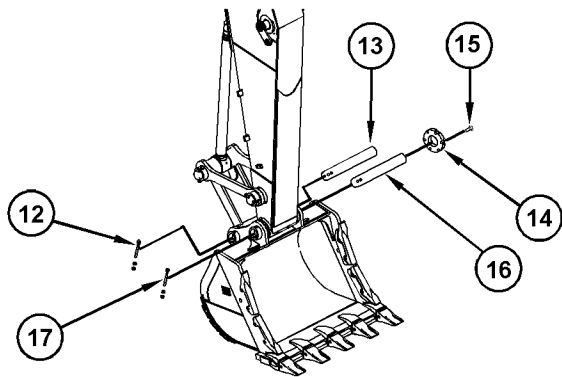

Illustration 293

g03822739

3. Remove nuts and retaining bolt (12) from support pin (13). Remove support pin (13).
4. Remove bolts (15) and adapter plate (14). Remove the shims.
5. Remove nuts and retaining bolt (17) from support pin (16). Remove support pin (16).
6. Start the engine and raise the stick out of the bucket.
7. Remove the O-ring seals (11) from the flanges on the bucket.

Note: After the support pins have been removed, make sure that the support pins do not become contaminated with sand or dirt. Make sure that the seals on the end of the stick and the seals on the end of the link do not become damaged.

Installation Procedure

1. Clean each pin and each pin bore. Lubricate each pin bore with molybdenum grease.

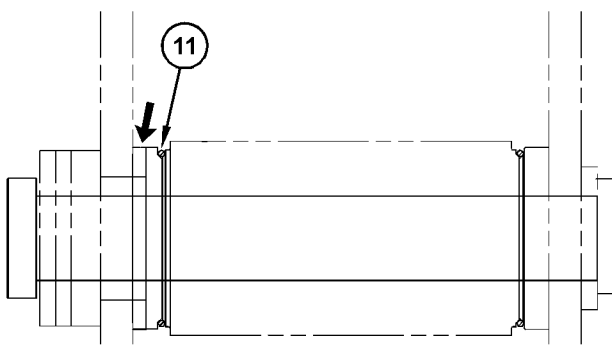

Illustration 294

g03822738

2. Position the O-ring seals (11) onto the flanges of the bucket.

3. Start the engine and lower the stick into the bucket until the pin bores are in alignment with each other. Stop the engine.

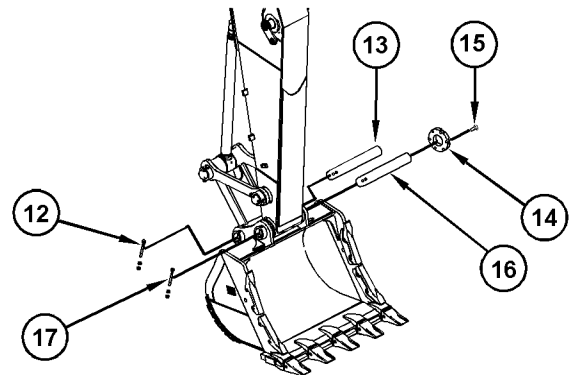

Illustration 295

g03822739

4. Install support pin (16). Put the retaining bolt hole that is in support pin (16) in alignment with the retaining bolt hole that is in the bucket.
5. Install the retaining bolt and nuts (17). Install adapter plate (14) without the shims, and without bolts (15) that hold adapter plate (14).
6. Refer to Operation and Maintenance Manual, "Bucket Linkage - Inspect/Adjust" in order to adjust the bucket clearance.
7. Slide O-ring seals (11) in position over the pin joints between the bucket and the stick.
8. Start the engine and position the bucket linkage into the bucket until the pin bores are in alignment with each other. Stop the engine.
9. Install support pin (13). Put the retaining bolt hole that is in the bucket pin in alignment with the retaining bolt hole that is in the bucket.
10. Install the retaining bolt and nuts (12).
11. Slide the O-ring seals (11) over the pin joints between the bucket and the link assembly.

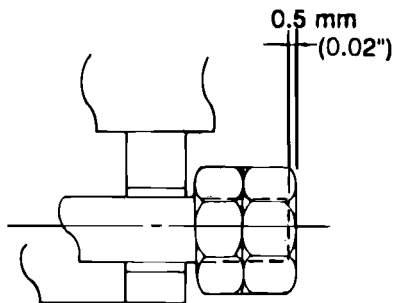

Illustration 296

g00510030

- 12.** Tighten retaining nuts (12) and (17). Position the outside nut even with the end of the retaining bolt or 0.5 mm (0.02 inch) beyond the end of the retaining bolt. Tighten the inside nut against the outside nut.

- 13.** Lubricate the bucket pins. Refer to Operation and Maintenance Manual, "Bucket Linkage - Lubricate" or Operation and Maintenance Manual, "Boom, Stick, and Bucket Linkage - Lubricate".

i07062223

Work Tool Operation (If Equipped)

SMCS Code: 6700; 7000

Hammer Operation (If Equipped)

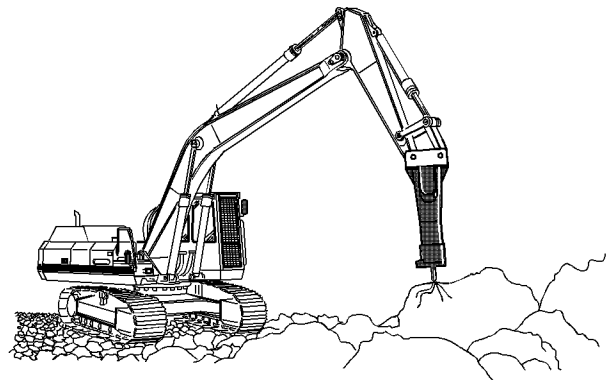

Illustration 297

g01876560

NOTICE

Use only a hydraulic hammer that is recommended by Caterpillar.

The use of a hydraulic hammer that is not recommended by Caterpillar could result in structural damage to the host machine.

Consult your Cat dealer for information on recommended hydraulic hammers.

Only use the hydraulic hammer to break rocks, concrete, and other hard objects. Before you start hydraulic hammer operation, place the machine on a level, stable surface.

Before you start hydraulic hammer operation, close the front window. Caterpillar recommends the installation of a window guard on the front window for protection from flying debris.

Operation Section
If Equipped

NOTICE

In order to avoid structural damage to the host machine or the hydraulic hammer, comply with the following:

Do not attempt to break rocks or concrete by burying the hammer tool completely into the rocks or concrete.

Do not apply a prying force to the hammer tool in order to remove the hammer tool from the material.

Do not allow the hydraulic hammer to operate at one location and for more than 15 seconds. Change the location of the hydraulic hammer and repeat the procedure. Failure to change the location of the hydraulic hammer could cause the hydraulic oil to overheat. Overheated hydraulic oil could damage the accumulator.

Stop the hydraulic hammer immediately if the jumper lines are pulsating violently. This indicates that the accumulator nitrogen charge is lost. Consult your Caterpillar dealer for the necessary repair.

NOTICE

Do not use the dropping force of the hydraulic hammer to break rocks or other hard objects. This could cause structural damage to the machine.

Do not use the sides or back of the hydraulic hammer to move rocks or other hard objects. Doing this could cause damage not only to the hammer but to stick or boom cylinder.

Do not operate the hydraulic hammer with any of the cylinders fully retracted or extended. Doing this could cause structural damage to the machine, resulting in reduced machine life.

Do not use the hydraulic hammer to lift an object.

Do not operate the hydraulic hammer while the stick is vertical to the ground. This could allow the stick cylinder to vibrate excessively.

Operate the attachment control levers carefully to keep the hydraulic hammer tool from hitting the boom.

Do not operate the hydraulic hammer under water unless the hydraulic hammer is properly equipped. Operating the hydraulic hammer under water could damage the machine hydraulic system. Consult your Caterpillar dealer for information on underwater operation.

Do not operate the hydraulic hammer with the upper structure sideways to the undercarriage. Before you start hydraulic hammer operation, place the upper structure in the recommended positions that are shown in illustration 298 . Any other operating positions could make the machine unstable. Any other operating positions could place excessive loads on the undercarriage.

Refer to the following for any additional questions about the operation and care of your Caterpillar hydraulic hammer: Operation and Maintenance Manual, SEBU7346, "Hydraulic Hammers", Operation and Maintenance Manual, HEPU9000, "Hydraulic Hammers" and Decal, SMEU7397, "Hammer Operation/Maintenance".

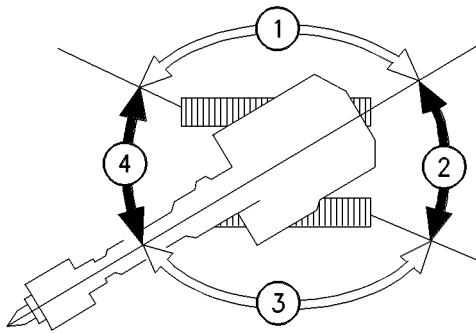

Illustration 298

g00101503

- (1) Not Recommended working position
- (2) Recommended working position
- (3) Not Recommended working position
- (4) Recommended working position

Shear Operation (If Equipped)

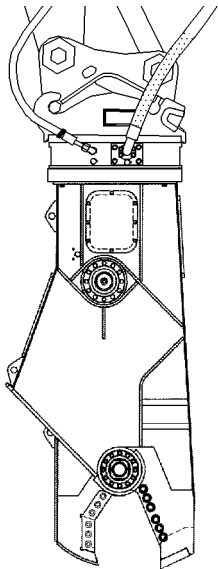

Illustration 299

g00763823

⚠ WARNING

Do not operate or work on this work tool unless you have read and understand the instructions and warnings in the Operation And Maintenance Manual for both the work tool and the host machine.

Failure to follow the instructions or heed the warnings could result in injury or death.

Contact your Caterpillar dealer for replacement manuals. Proper care is your responsibility.

NOTICE

Selection of a hydraulic shear must be done with extra care.

Use of a hydraulic shear not recommended by Caterpillar could result in structural damage to the host machine.

Consult your Cat dealer for hydraulic shear information.

Be sure that no one is near the work tool to prevent injury. Keep the work tool under control always to prevent injury. When a demolition tool is used, all personnel should maintain a minimum distance of 10 m (33 ft).

Close all windows. Make sure that all required guards are in place. Wear all required protective equipment. Follow the instructions in the Operation and Maintenance Manual for the work tool.

⚠ WARNING

Serious injury or death could occur from the demolition of pipes, vessels, tanks or other containers that may contain gas, flammable materials or hazardous chemicals.

Do not perform any demolition work on these items until all of their contents have been removed.

Follow all regulations for the removal and disposal of these materials.

NOTICE

Using the demolition tool to level the work site or push over standing structures may damage the machine or the demolition tool. Use appropriate equipment to do site preparation or maintenance operations.

NOTICE

To avoid structural damage to the machine, do not break road surfaces by placing the cutting edge of the hydraulic shear on the ground and moving the machine.

Crusher Operation (If Equipped)**⚠ WARNING**

Improper operation and maintenance of the crusher could cause personal injury or death. Observe the following procedures for safe operation of the crusher.

Consult your Cat dealer for more information on the operation and maintenance of the crusher.

Do not operate the host machine with the work tool unless you have read and understood the instructions and warnings in the Operation and Maintenance Manual. Failure to follow the instructions or heed the warnings could result in machine or work tool damage, and/or serious injury or death. Contact your Cat dealer for a replacement manual, if needed.

When the crusher is installed on the host machine, always make sure that the protective guarding is in place.

Using the crusher in an incorrect manner can damage the machine and/or cause personal injury or death.

Always ensure that the work area is clear of ground personnel, due to the potential crush hazards with falling debris and machine movement.

Resting or placing your foot on the work tool pedal could result in unexpected movement of the machine / work tool which could result in personal injury or death. Always lock the crusher when not in use.

NOTICE

Selection of a hydraulic crusher must be done with extra care.

Use of a hydraulic crusher not recommended by Caterpillar could result in structural damage to the host machine.

Consult your Cat dealer for hydraulic crusher information.

Close all windows. Make sure that all required guards are in place. Wear all required protective equipment. Follow the instructions in the Operation and Maintenance Manual for the work tool.

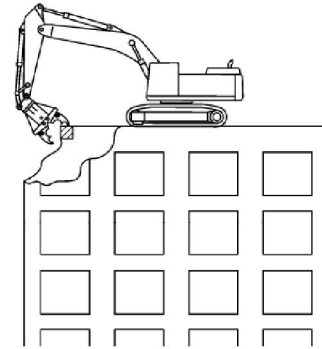

Illustration 300

g02688698

Demolition work on the roof of a building could lead to serious personal injury if the building were to collapse and the excavator turned over or fell off the roof. The demolition work must be started ONLY AFTER surveying the building for its structural integrity.

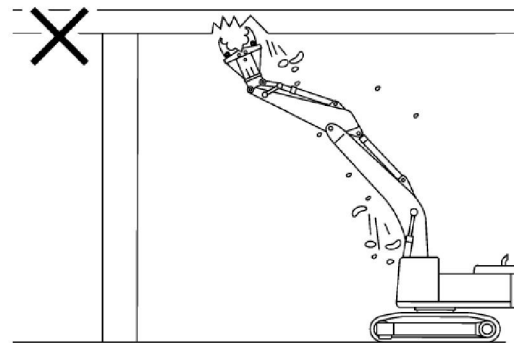

Illustration 301

g02688699

Crushing work above your head must be avoided because objects can fall and damage the machine.

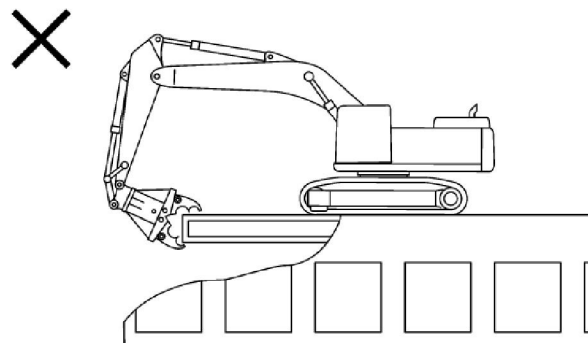

Illustration 302

g02688700

Do not perform demolition work at the base of the machine, because the ground could be unstable and cause the machine to fall.

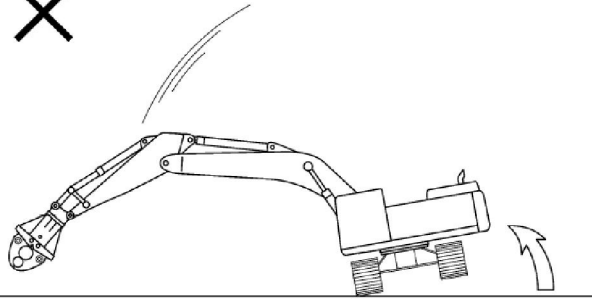

Illustration 303

g02688702

Do not suddenly lower or stop the work tool, otherwise the excavator could turn over.

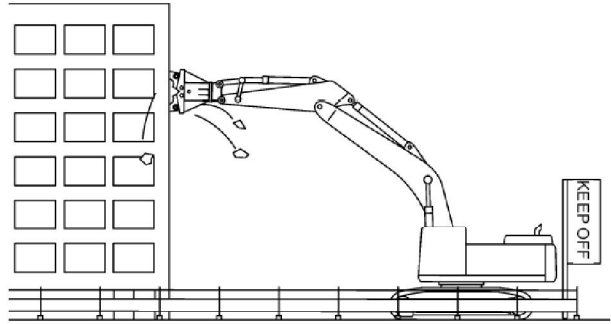

Illustration 306

g02688706

When performing work at elevated positions, always use care for the surroundings and for falling objects to avoid personal injury. Use guide personnel and signs as required.

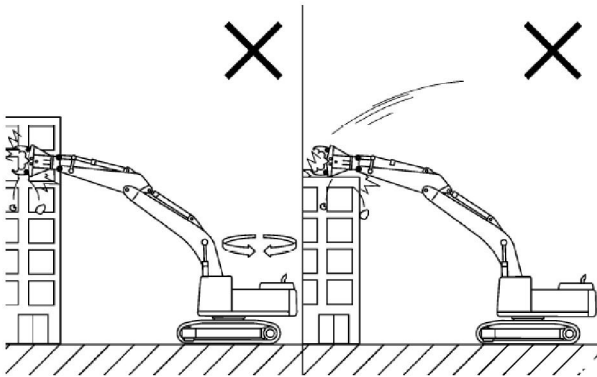

Illustration 304

g02688704

Crushing work using impact, swing, or dropping forces of the excavator could cause damages to the machine and also could lead to personal injury. As such, NEVER perform such an operation.

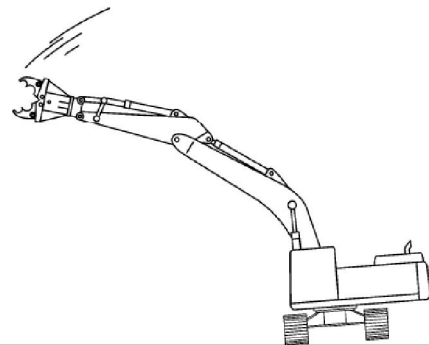

Illustration 307

g02688709

When working sideways, the track can lift. Avoid abrupt operation and operate slowly.

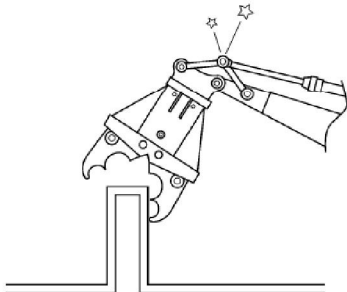

Illustration 305

g02688705

Crushing work with hydraulic cylinder at stroke end position could damage the excavator, resulting in shortening of lifespan. Also, as it could lead to unexpected personal injury due to breakage of the machine, do not perform any work at stroke end.

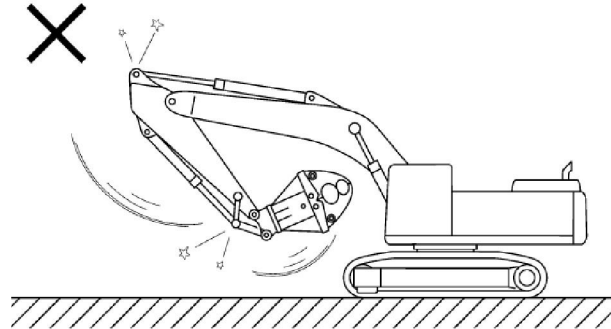

Illustration 308

g02688786

Crushers could interfere with the boom and the cab depending on the type and method of usage. Know the working range of the crusher being used.

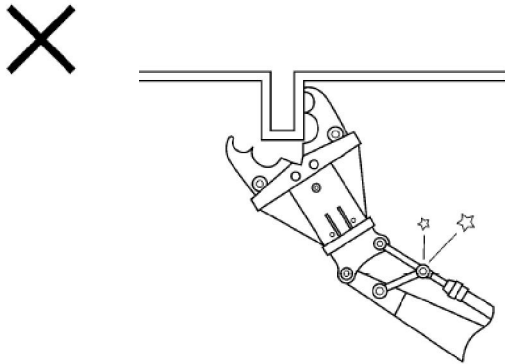

Illustration 309

g02688790

If the tooth of the crusher engages an object at a slant, excessive forces could be applied to the front regions. As such move the crusher to the front.

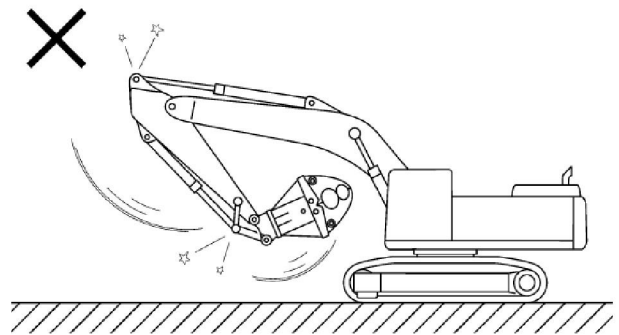

Illustration 311

g02688786

Sudden extension of the bucket cylinder, or sudden extension of the stick cylinder could cause damages at the stroke end position, resulting in personal injury. Operations that cause sudden extension of the cylinders is PROHIBITED!

i00793291

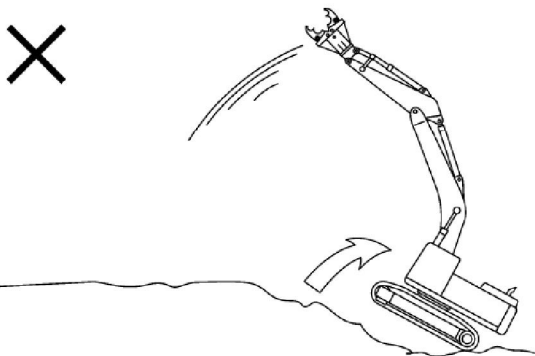

Illustration 310

g02688792

Never extend the boom cylinder suddenly. Sudden extension of the boom could cause tip backwards.

Blade Operation (If Equipped)

SMCS Code: 6060

NOTICE

Avoid hitting or moving rocks using the blade. Blade and cylinder damage could occur.

When using the blade as outrigger, be sure to support the machine with the edge of the blade against the ground. When curling the front attachment, do not allow the bucket to hit the blade.

During digging operation, do not allow the boom cylinder to contact the blade edge. When no blade operation is needed, operate with the bucket on the opposite side of the machine from the blade.

Do not swing the upper structure with cab door and/or upper structure covers opened. An opened door and/or cover can hit the blade when the blade is in the raised position while the machine is swinging.

Parking

i01871055

Stopping the Machine

i04176310

SMCS Code: 7000

WARNING

Leaving the machine unattended when the engine is running may result in personal injury or death. Before leaving the machine operator station, neutralize the travel controls, lower the work tools to the ground and deactivate all work tools, and place the lever for the hydraulic lockout control in the LOCKED position.

Note: There may be regulations that define the requirements for the operator and/or support personnel to be present when the engine is running.

Park on a level surface. If the machine must be parked on a grade, chock the tracks securely.

Note: The swing parking brake is automatically applied when the machine is stopped. The swing parking brake is released when the engine is running and the joystick is activated.

1. Turn the engine speed dial counterclockwise in order to reduce engine speed.

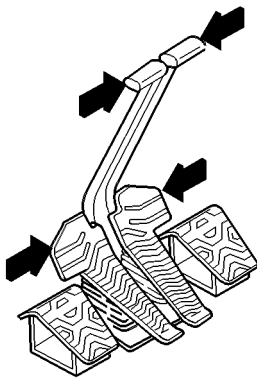

Illustration 312

g00560313

2. Release the travel levers/pedals in order to stop the machine.
3. Lower the work tool to the ground. Apply a slight downward pressure.
4. Move the hydraulic lockout control to the LOCKED position.

Freezing Conditions

SMCS Code: 7000

If freezing temperatures are expected, remove the mud and the dirt from each track roller frame. Park the machine on wood planks. Use the following procedure to clean each track roller frame.

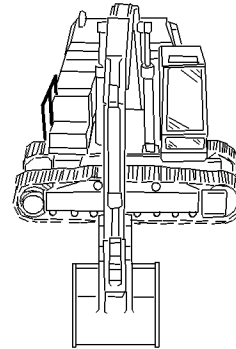

Illustration 313

g00101644

1. Position the boom over one side of the machine.
2. Use boom down pressure in order to lift the track on one side off the ground. Operate the track in the forward direction. Then operate the track in reverse. Continue this procedure until the maximum amount of material is thrown off the track.
3. Lower the track onto the wood planks.
4. Repeat the procedure for the other track.
5. Clean the area around the carrier rollers and around the track rollers.
6. Lower the work tool onto a wood plank in order to prevent the work tool from touching the ground.

i05969375

Stopping the Engine

SMCS Code: 1000; 7000

NOTICE

Stopping the engine immediately after it has been working under load can result in overheating and accelerated wear of engine components.

Refer to the following procedure to allow the engine to cool and to prevent excessive temperatures in the turbocharger housing, which could cause oil coking problems.

NOTICE

Never turn the battery disconnect switch to the OFF position while the engine is running. Serious damage to the electrical system may result.

1. Park the machine on level ground. Refer to Operation and Maintenance Manual, "Stopping the Machine" for the recommended procedure.
2. While the machine is stopped, run the engine for 5 minutes at low idle. Idling the engine allows hot areas of the engine to cool gradually.
3. Turn the engine start switch to the OFF position and remove the key.

Note: If the "Regen Active" indicator is illuminated, do not shut off the engine. Refer to Operation and Maintenance Manual, "Monitoring System" for more information on indicators.

Engine Stop Control

Turn the engine start switch to the OFF position. If the engine does not stop, perform the following procedure.

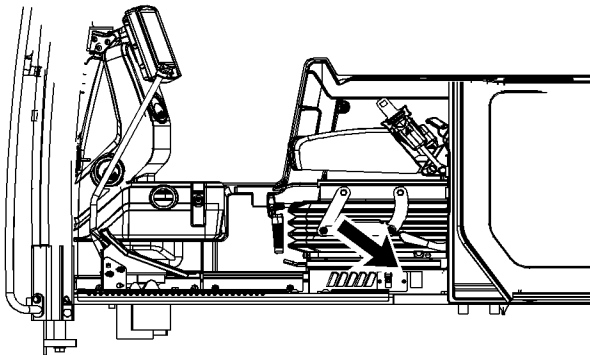

Illustration 314

g02038995

1. The switch is located below the left side of the operator seat.

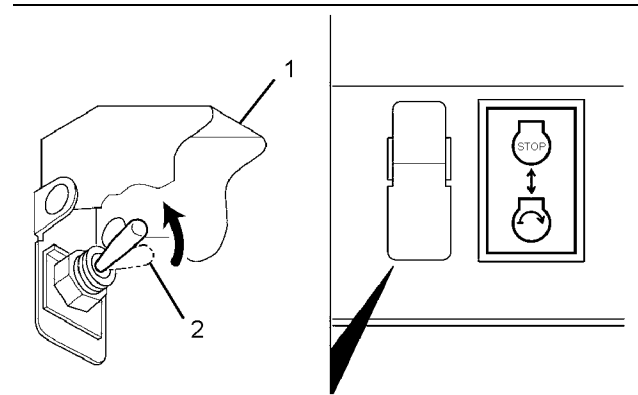

Illustration 315

g01048511

2. Lift cover (1).
3. Push switch (2) upward. This should stop the engine.

Note: Use the engine start switch to stop the engine first. Use the engine stop control as an alternate method to stop the engine.

4. Return the switch to the original position. The engine will be enabled to start.

Note: Do not operate the machine again until the malfunction has been corrected.

5. Use the method that follows if the previous steps do not stop the engine.

Stop the Engine if an Electrical Malfunction Occurs

Turn the engine start switch to the OFF position. If the engine does not stop, perform the following procedure.

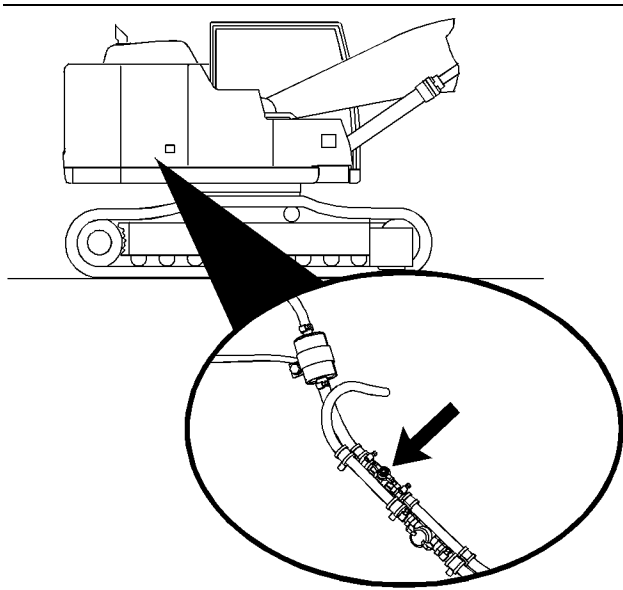

Illustration 316

g03742236

The fuel shutoff valve is located behind the right access door.

Shut off the fuel supply by turning the fuel shutoff valve clockwise. The engine will stop after consuming the fuel in the fuel line. The engine may continue to run for a few minutes.

Repair the engine before you restart the engine. The fuel system may need to be primed. See Operation and Maintenance Manual, "Fuel System - Prime" for instructions.

i06299353

Leaving the Machine

SMCS Code: 7000

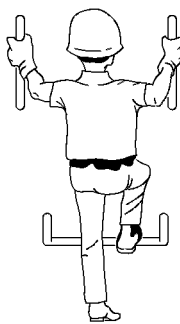

Illustration 317

g00037860

1. Use the steps and the hand holds when you dismount. When you dismount, face the machine and use both hands.

2. Inspect the engine compartment for debris. Clean out any debris in order to avoid a fire hazard.
3. Remove all flammable debris from the front bottom guard through the access doors in order to reduce a fire hazard. Discard the debris properly.
4. Always turn the battery disconnect switch to the OFF position before leaving the machine.
5. If the machine will not be operated for a month or more, remove the battery disconnect switch key.
6. Lock all compartments and all vandalism covers (if equipped).

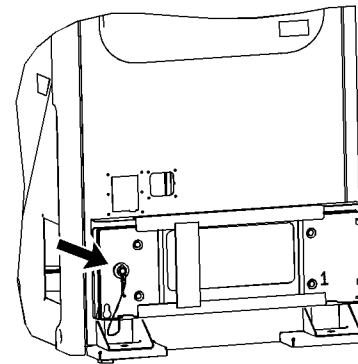

Illustration 318

g02038843

7. Remove the bolt that holds the vandalism guards in place. Remove the vandalism guards from the storage area.

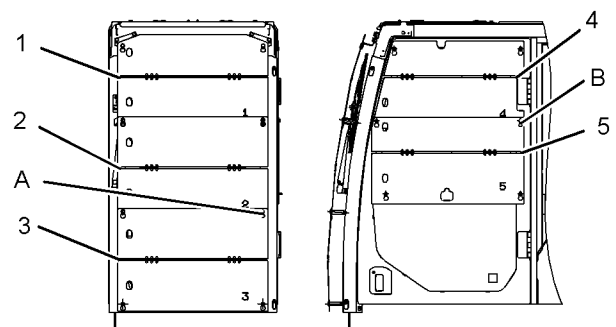

Illustration 319

g02148267

8. Install the vandalism guards on the front window and on the cab door. An identification number is stamped on each of the vandalism guards. Install the vandalism guards in the correct sequence. Use bolts (A) only for vandalism guard (3) and for vandalism guard (5).

Note: When you are storing the vandalism guards, make sure that you place the guards in the storage area in sequential order. The vandalism guards will only fit in the storage area in this manner.

Transportation Information

i07200040

Shipping the Machine

SMCS Code: 7000; 7500

WARNING

Automatic Engine Speed Control (AEC) will increase engine speed automatically when you operate the control levers and/or travel pedals with AEC switch on.

When loading and unloading the machine from the truck or working in close quarters always turn AEC switch off to prevent any possibility of sudden movement of machine, which could result in serious injury or death.

Set the travel speed control switch to LOW before loading the machine. Never operate this switch when loading the machine on a trailer.

Investigate the travel route for overpass clearances. Make sure that there will be adequate clearance for the machine.

Remove ice, snow, or other slippery material from the loading dock and from the truck bed before you load the machine onto the transport machine. Removing ice, snow, or other slippery material will help to prevent the machine from slipping in transit.

Note: Obey all laws that govern the characteristics of a load (height, weight, width, and length). Observe all regulations that govern wide loads.

Choose the flattest ground when you load the machine or when you unload the machine.

1. Before you load the machine, chock the trailer wheels or the rail car wheels.
2. When you use loading ramps, make sure that the loading ramps have adequate length, adequate width, adequate strength, and an adequate slope.
3. Maintain the slope of the loading ramps within 15 degrees of the ground.
4. Position the machine so that the machine can drive straight up the loading ramps. The final drives should be toward the rear of the machine. Do not operate the control levers while the machine is on the loading ramps.
5. When you drive over the loading ramp joint areas, maintain the balance point of the machine.
6. Lower the work tool to the bed or to the floor of the transport machine.

7. To prevent rolling of the machine or sudden movement of the machine, perform the following items:

- Chock both tracks.
- Install sufficient tie-downs at several locations.
- Fasten wire cables.

NOTICE

Do not allow the chrome surface of the bucket cylinder rod to touch any part of the trailer. Damage to the rod can occur from impact with the trailer during transport.

Note: Refer to Operation and Maintenance Manual, "Specifications".

Shipping a Machine that is not Completely Assembled

If the machine must be shipped when the boom, stick, or counterweight is not assembled on the machine, follow the instructions in Operation and Maintenance Manual, "Operation".

WARNING

The ROPS structural certification depends on the support of the boom, stick, and counterweight in the event of a machine tip over or a machine rollover incident.

When the machine needs to be moved without the boom, stick, or counterweight being installed, avoid any machine operations which could affect machine stability as a machine tip over or a machine rollover incident could result in serious injury or death.

The machine should be operated slowly on flat, stable ground or pavement by qualified operators.

i06630014

Securing the Machine

SMCS Code: 7000

Comply with any laws that govern the characteristics of a load (length, width, height, and weight).

Operation Section
Securing the Machine

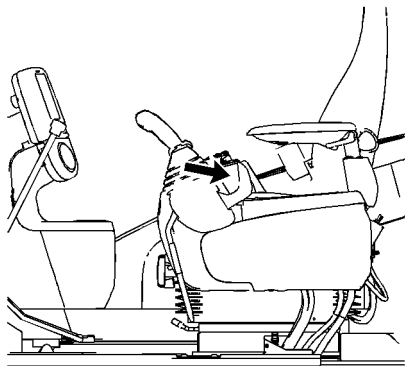

Illustration 320

g01075262

1. Move the hydraulic lockout control to the LOCKED position.
2. Turn the engine start switch to the OFF position in order to stop the engine. Remove the engine start switch key.
3. Turn the battery disconnect switch to OFF and remove the disconnect switch key.
4. Remove the ether starting aid cylinder. See Operation and Maintenance Manual, "Ether Starting Aid Cylinder - Replace" for the removal procedure.
5. Lock the door and the access covers. Attach any vandalism protection.
6. The Product Link antenna (if equipped) may be repositioned in order to meet the regulations regarding height of some locations. The Product Link antenna is located on top of the cab. Perform the following procedure in order to move the Product Link antenna to the transport position.

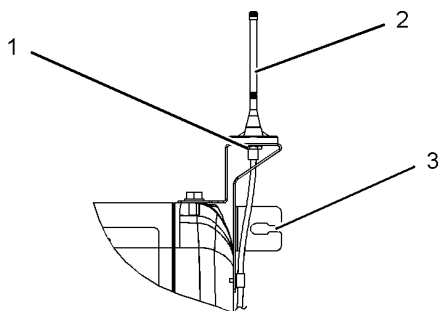

Illustration 321

g01438598

- a. Loosen nut (1).

- b. Remove antenna (2) and place the antenna in hole (3).
- c. Tighten nut (1).

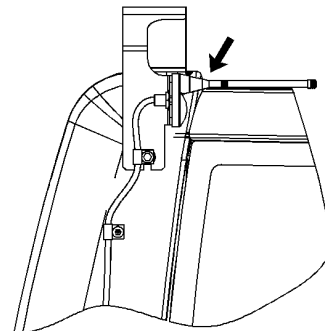

Illustration 322

g01438821

Antenna for Product Link in transport position

- d. Return the antenna to the operational position before operating the machine.
7. The AccuGrade antenna (if equipped) must be repositioned for transport. The AccuGrade antenna is located on top of the cab. Perform the following procedure in order to move the AccuGrade antenna to the transport position.

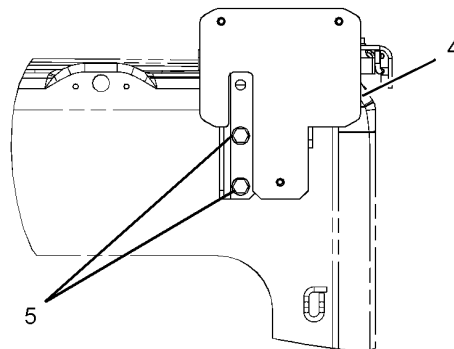

Illustration 323

g02177286

Bracket in position for operation

- a. Remove bolts (5) from bracket (4).

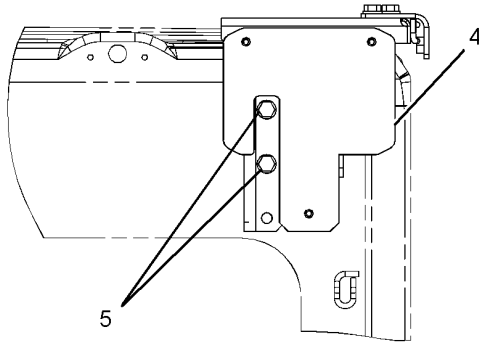

Illustration 324

g02177305

Bracket in position for transport

- b. Reinstall bracket (4) with bolts (5) located in the top two holes of the bracket. Refer to Illustration 324 .

Note: The bracket for the AccuGrade antenna must be place back into the normal operating position before the machine can be placed back into service.

8. The side view camera is located on top of the fuel tank and it must be repositioned for transport. Perform the following procedure in order to move the camera to the transport position.

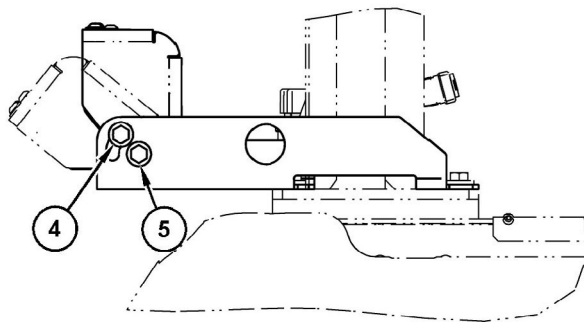

Illustration 325

g06051521

Side view camera in position for transport

- a. Loosen bolts (4) and (5) and slide the camera upward to the transport position.
- b. Tighten bolts (4) and (5).

Note: The side view camera must be placed back into the normal operating position before the machine can be placed back into service.

9. Cover the exhaust opening.

NOTICE

Do not allow the turbocharger to rotate while the engine is not operating. Damage to the turbocharger can result.

Note: Before you remove the excavator from the transport machine, remove the protective covering from the exhaust opening.

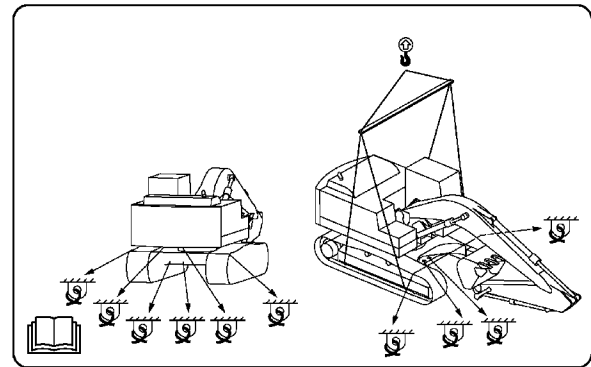

Illustration 326

g02444887

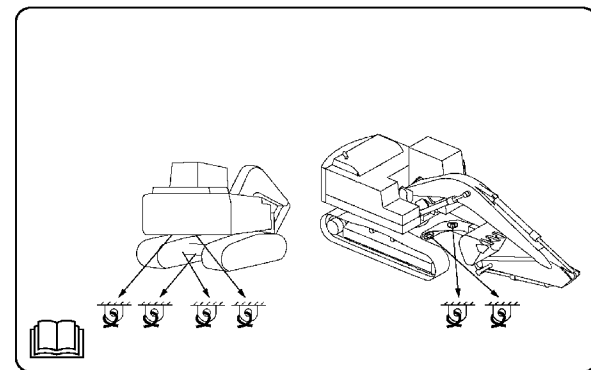

Illustration 327

g02104975

10. Chock the tracks and secure the machine with tie-downs. Make sure that you use the proper rated wire cable.

Use the front towing eyes and the rear towing eyes on the lower frame, and the rear towing eye on the upper frame.

Securely fasten all loose parts and all removed parts to the trailer or to the rail car.

When the engine is stopped, the swing parking brake is automatically applied. This action prevents the upper structure from swinging.

NOTICE

In freezing weather, protect the cooling system with antifreeze, to the lowest outside expected temperature on the travel route. Or, drain the cooling system completely.

i02511059

Mirror Installation

SMCS Code: 7319



Illustration 328

g01257076

The mirror is used to help the operator view the rear of the machine.

Install the mirror on the counterweight. Tighten the bolts until the mirror is secure. Do not overtighten the bolts.

Adjust the mirror before you operate the excavator. Use the step behind the counterweight in order to adjust the mirror. Maintain three points of contact with the step while you adjust the mirror.

i07819227

Lifting and Tying Down the Machine

SMCS Code: 7000; 7500

WARNING

Improper lifting and tie-down techniques can allow the load to shift or fail resulting in personal injury or property damage. Use only properly rated cables and slings with lift and tie down points provided on the machine. Keep the deck of the transport vehicle clean and use anti-slip mats on steel decks.

Follow the instructions in Operation and Maintenance Manual, "Lifting and Tying Down the Machine" for the proper technique for securing the machine. Refer to Operation and Maintenance Manual, "Specifications" for specific weight information.

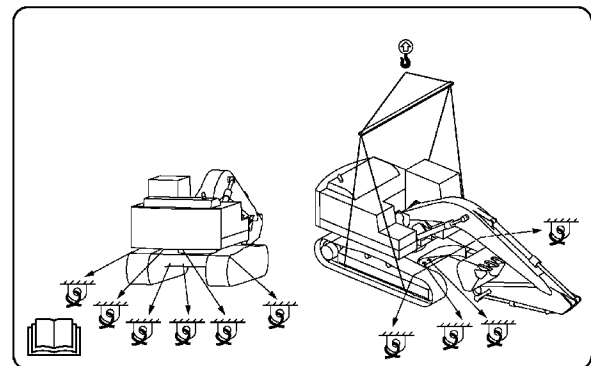

Illustration 329

g02444887

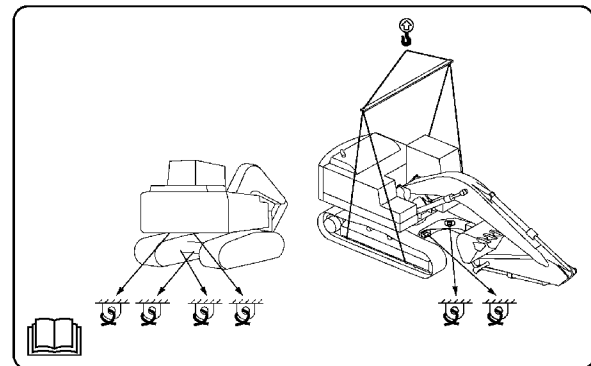

Illustration 330

g02097575

The lift and tie-down film is located near the base of the boom.

Lifting the machine

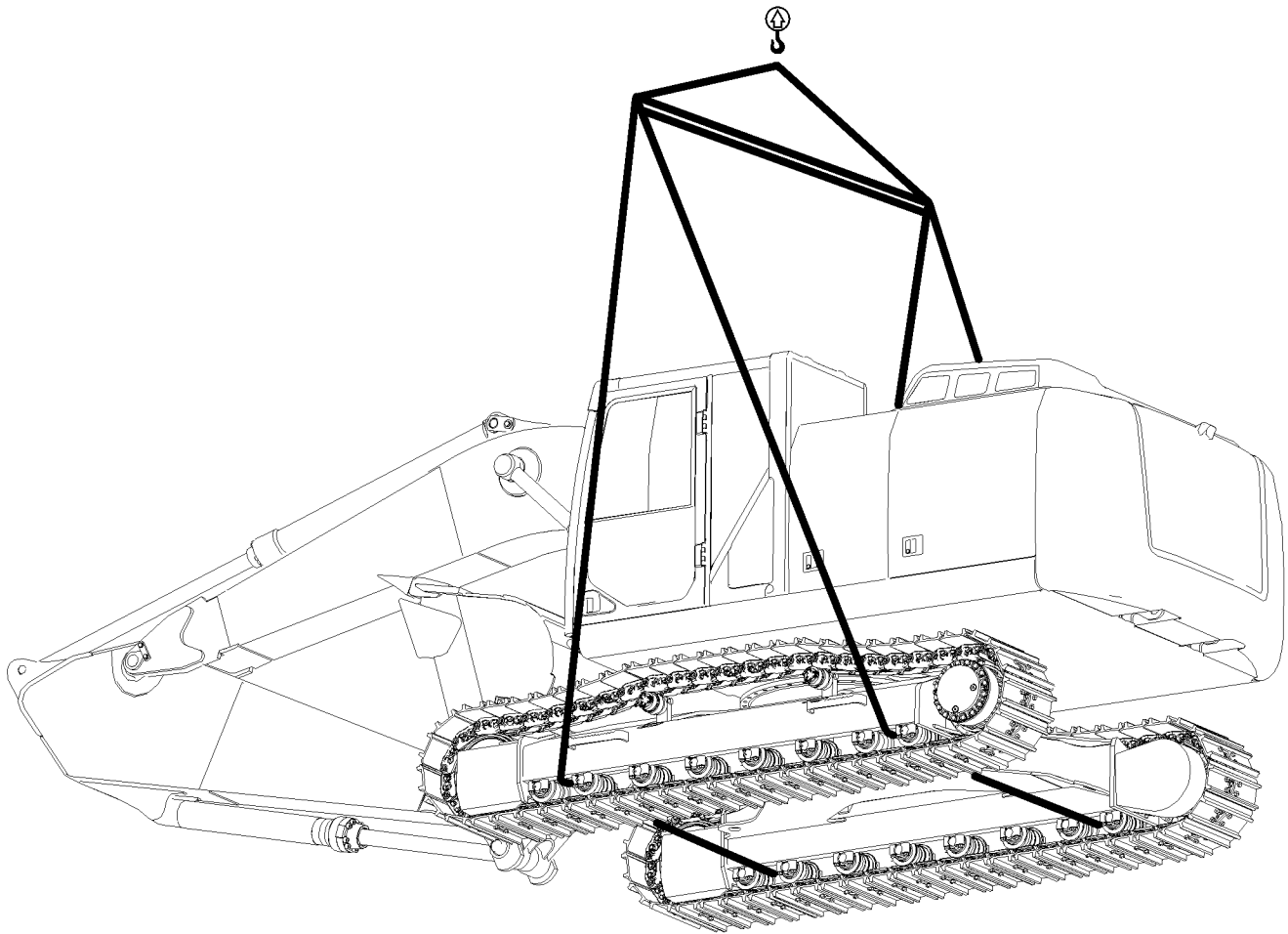

Illustration 331

g02793463

The machine center of gravity is at the center of the swing gear.



Lifting Point – To lift the machine, attach the lifting devices to the lifting points.

The weight and the instructions that are given herein describe the machine as the machine is manufactured by Caterpillar.

Refer to the Operation and Maintenance, “Specifications” for specific weight information.

Note: Only lift objects from approved lifting points and with approved lifting devices

1. Use proper rated cables and slings for lifting. The crane should be positioned so that the machine is lifted parallel to the ground.
2. To prevent contact with the machine, lifting cables should have sufficient length.

3. Move the hydraulic lockout control to the LOCKED position.
4. Thread the cable between the first and second rollers at each end of the track.
5. Do not use the foot step as a lifting point.
6. If the full length roller guard is equipped, remove the guard.
7. Apply the proper protector to prevent machine/wire damage and slippage. Make sure that the rollers are not affected by the load.

Tying Down the Machine

There are two methods that can be used to tie down a machine. Local and/or regional regulations will determine which method to use.

Note: Obey all local and regional governmental regulations.

Frictional and Direct Lashing

When allowed, a combination of frictional lashing and direct lashing is the preferred method to tie down a machine.

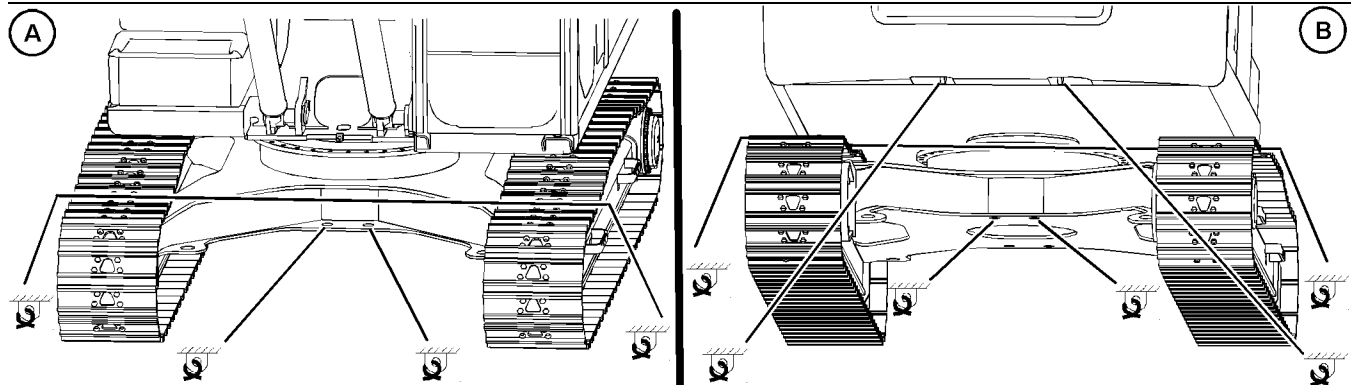

Illustration 332

g02793465

(A) Front of the machine

(B) Rear of the machine

Diagonal Lashing

In areas where frictional lashing is not allowed, diagonal lashing can be used as shown below.

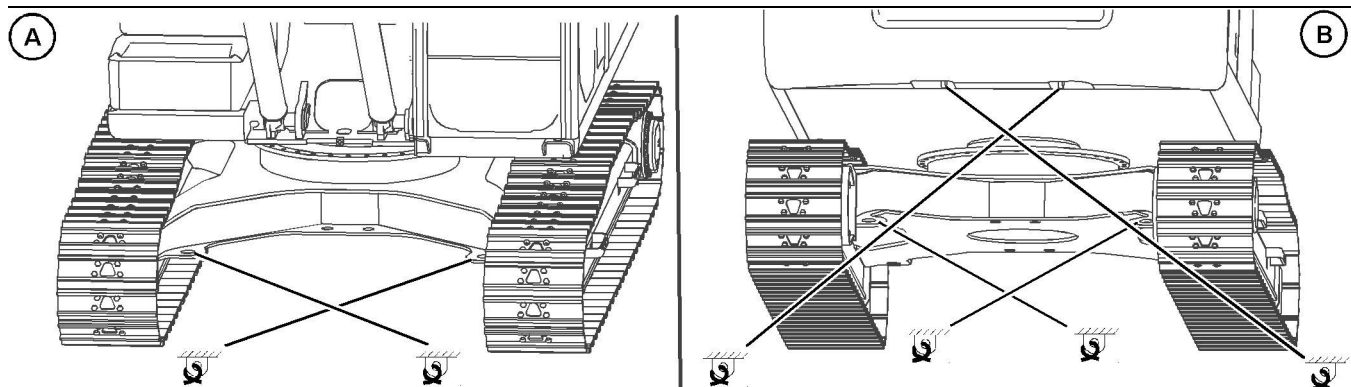

Illustration 333

g06434381

(A) Front of the machine

(B) Rear of the machine

Tying Down the Machine



Tie Down Point – To tie down the machine, attach the tie-downs to the tie-down points.

The weight and the instructions that are given herein describe the machine as the machine is manufactured by Caterpillar.

Refer to the Operation and Maintenance, “Specifications” for specific weight information.

1. Use proper rated cables and shackles for tying down the machine.
2. Use the rear eyes and the front eyes that are provided on the lower frame to fasten tie-downs. Use corner protectors for sharp corners.
3. Move the hydraulic lockout control to the LOCKED position.

4. If there is a requirement of diagonal lashing for tying down, use the proper tie-down point on the lower frame. Set the lashing angle which is on the longitudinal axis of the machine and the cable, at 30 to 50 degrees.
5. Keep the transport vehicle surface clean (for example, trailer deck).
6. For steel deck transport vehicles use skid-inhibiting or anti-slip mats (for example, rubber mats) with a friction coefficient of at least 0.3.

Machines Equipped with Blade

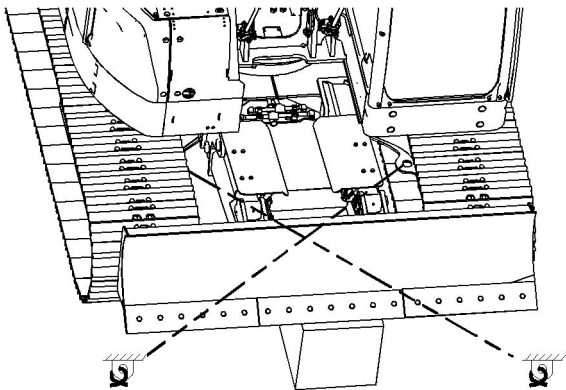

Illustration 334

g06445452

Note: The counterweight must not be positioned over the blade to properly tie down the upper structure under the counterweight.

1. Raise the blade and support the blade with proper blocking equipment.

Note: Support the blade high enough to avoid contacting the tie-downs.

The height of blocking equipment requirement is approximately 450 mm.

2. Use the proper tie-down point on the lower frame. Set the lashing angle which is on the longitudinal axis of the machine and the cable, at 30 to 50 degrees.

Lifting the Machine Segments

Bucket

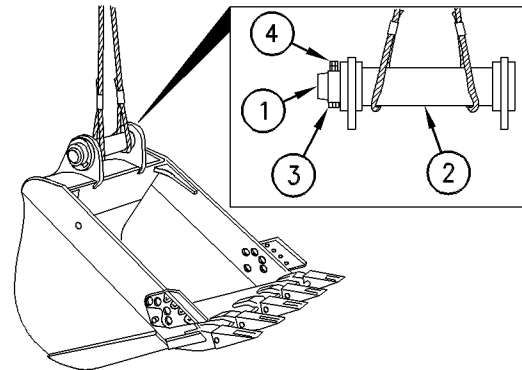

Illustration 335

g00115251

(1) Pin. (2) Sleeve. (3) Bolts. (4) Nuts.

Install pin (1) and install sleeve (2) in the brackets of the bucket. The previous illustration indicates the method to secure pin (1) with bolts (3) and nuts (4). Fasten two proper rated wire cables to pin (1).

Towing Information

i05662590

Towing the Machine

SMCS Code: 7000

WARNING

Personal injury or death could result when towing a disabled machine incorrectly.

Block the machine to prevent movement before final drives are disengaged. The machine can roll free if it is not blocked. With final drives disengaged, the machine cannot be stopped or steered.

Follow the recommendations below, to properly perform the towing procedure.

Relieve the hydraulic tank and line pressure before any disassembly.

Even after the machine has been turned off, the hydraulic oil can still be hot enough to burn. Allow the hydraulic oil to cool before draining.

NOTICE

To tow the machine, both final drives must be disengaged.

Do not operate the travel motors with the final drives disengaged. Damage could result.

These towing instructions are for moving a disabled machine for a short distance at low speed. Move the machine at a speed of 2 km/h (1.2 mph) or less to a convenient location for repair. Always haul the machine if long distance moving is required.

Shields must be provided on both machines. This will protect the operator if the tow line or the tow bar breaks.

Do not allow an operator to be on the machine that is being towed.

Before you tow the machine, make sure that the tow line or the tow bar is in good condition. Do not use a wire rope that is kinked, twisted, or damaged. Make sure that the tow line or the tow bar has enough strength for the towing procedure that is involved. The strength of the tow line or of the tow bar should be at least 150 percent of the gross weight of the towed machine. This requirement is for a disabled machine that is stuck in the mud and for being towed on a grade.

Do not use a chain for pulling a disabled machine. A chain link can break. This may cause personal injury. Use a wire rope with ends that have loops or rings. Put an observer in a safe position in order to watch the pulling procedure. The observer can stop the procedure if the wire rope starts to break. Stop pulling whenever the towing machine moves without moving the towed machine.

During towing, do not allow anyone to step between the towing and the towed machines.

Do not allow the wire rope to be straddled while the machine is being towed.

Keep the tow line angle to a minimum. Do not exceed a 30 degree angle from the straight ahead position.

Avoid towing the machine on a slope.

Quick machine movement could overload the tow line or the tow bar. This could cause the tow line or the tow bar to break. Gradual, steady machine movement will be more effective.

Prior to releasing the brake of the final drive, firmly lock both tracks in order to prevent the machine from moving suddenly. When the machine is ready to be towed, release the brake of the final drive. Refer to Operation and Maintenance Manual, "Final Drive Ring Gear Removal".

Normally, the towing machine should be as large as the disabled machine. Make sure that the towing machine has enough brake capacity, enough weight, and enough power. The towing machine must be able to control both machines for the grade that is involved and for the distance that is involved.

You must provide sufficient control and sufficient braking when you are moving a disabled machine downhill. This may require a larger towing machine or additional machines that are connected to the rear of the disabled machine. This will prevent the machine from rolling away out of control.

All situation requirements cannot be listed. Minimal towing machine capacity is required on smooth, level surfaces. Maximum towing machine capacity is required on an incline or on a surface that is in poor condition.

Do not tow a loaded machine.

Consult your Cat dealer for the equipment that is necessary for towing a disabled machine.

Retrieval and Towing of Machine

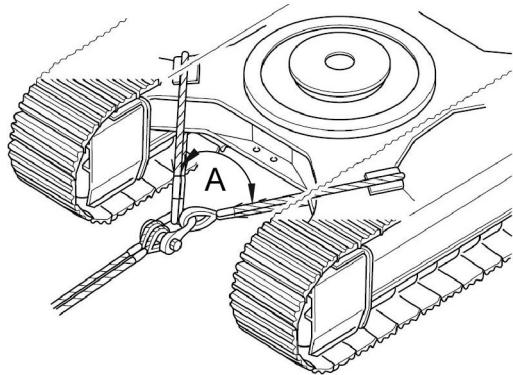

Illustration 336

g02533437

Note: Shackles must be used for towing the machine. The wire rope should be horizontal and straight to the track frame.

Install a properly rated wire rope to the lower frame of the towing machine and the lower frame of the towed machine. The permissible force for the lower frame is 100 percent of the gross weight of the towed machine.

Note: In order to prevent damage to the wire rope or the lower frame of the machines, use protective sleeves on the corners of the lower frame.

Retrieve the disabled machine carefully. The applied load for each wire rope should be equal. The angle (A) between each wire rope should be 60 degree maximum. Operate the machine at a low speed.

Lightweight Towing

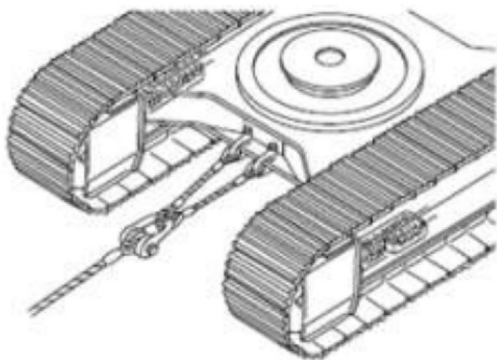

Illustration 337

g03589894

The maximum load for lightweight towing is 57000 N·m (42041 lb ft).

Shackles must be used for towing the machine. The wire rope should be horizontal and straight to the track frame.

Install a properly rated wire rope to the lower frame of the towing machine and the lower frame of the towed machine. Operate the machine at a low speed.

i06139738

Final Drive Ring Gear Removal

SMCS Code: 4050

WARNING

Without the ring gear in place, the brakes are ineffective. Personal injury or death could result. Provide other means to hold or stop the machine.

Table 49

Suggested Tools			
Item	Part Number	Description	Qty
A	128 - 5049	Guide Stud	2
B	1P - 0074	Slide Hammer Puller Gp	1
	4C - 5655	Adapter	1

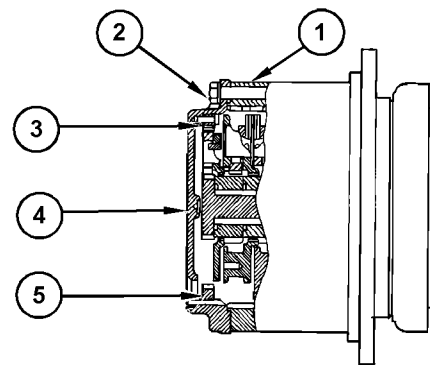

Illustration 338

g03822829

- (1) Ring gear
- (2) Cover bolts
- (3) Bolts
- (4) Final drive cover
- (5) Ring gear

1. Thoroughly clean the area around the final drive. Make sure that you also clean the track shoes that are positioned above the final drive.

Note: Refer to Operation and Maintenance Manual, "General Hazard Information" for information that pertains to Containing Fluid Spillage.

Operation Section
Final Drive Ring Gear Removal

2. Drain the final drive oil into a suitable container. See Operation and Maintenance Manual, "Final Drive Oil - Change" for the procedure.
3. Remove one track shoe in order to allow access to the face between final drive cover (4) and ring gear (1).

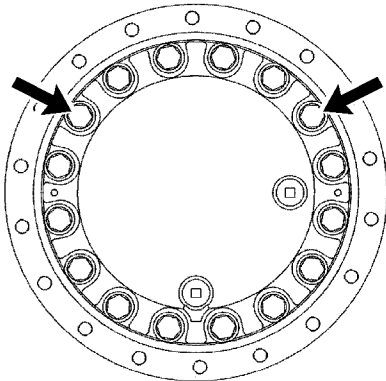

Illustration 339

g01846274

4. Remove two bolts (2). Attach Items (A). This is necessary in order to support ring gear (1) while you remove the final drive cover.

Note: If Item (A) is unavailable, you may use alignment dowels. Make sure that the alignment dowels are able to support the ring gear (1) while you remove the final drive cover.

5. Remove the remaining bolts (2) from the final drive cover.

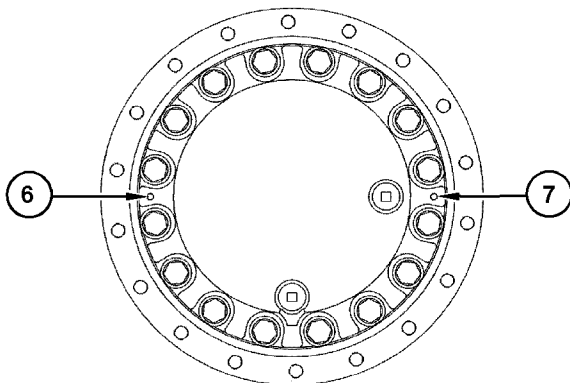

Illustration 340

g03822834

6. Install Item (B) into the final drive cover (1) at location (6) or (7). Use Item (B) in order to separate final drive cover (4) and ring gear (1). Make sure that ring gear (1) stays in place.

Note: If Item (B) is unavailable, you may use a hammer and a wedge in order to separate the final drive cover and the ring gear.

7. Remove twelve bolts (3) and ring gear (5) from final drive cover (4).
8. Apply Gasket Sealant to the mating surface of cover (4) and the housing.
9. Install final drive cover (4) and all cover bolts (2).
10. Fill the final drive with new oil. See Operation and Maintenance Manual, "Final Drive Oil - Change" for the procedure.
11. Repeat this procedure for the other final drive.
12. Refer to the Service Manual for information on the installation of the final drive ring gear.

Engine Starting (Alternate Methods)

i02499435

Engine Starting with Jump Start Cables

SMCS Code: 1000; 7000

WARNING

Failure to properly service the batteries may cause personal injury.

Prevent sparks near the batteries. They could cause vapors to explode. Do not allow the jump start cable ends to contact each other or the machine.

Do not smoke when checking battery electrolyte levels.

Electrolyte is an acid and can cause personal injury if it contacts skin or eyes.

Always wear eye protection when starting a machine with jump start cables.

Improper jump start procedures can cause an explosion resulting in personal injury.

Always connect the battery positive (+) to battery positive (+) and the battery negative (-) to battery negative (-).

Jump start only with an energy source with the same voltage as the stalled machine.

Turn off all lights and accessories on the stalled machine. Otherwise, they will operate when the energy source is connected.

Note: Do not allow the stalled machine to touch the machine that is used as the electrical source.

Note: Use only equal voltage for starting. Check the battery and check the starter for the voltage ratings of your machine. Use only the same voltage for jump starting. Use of a welder at higher voltage will damage the electrical system.

Note: Severely discharged maintenance free batteries do not fully recharge from the alternator after jump starting. The batteries must be charged to proper voltage with a battery charger. Typically, most batteries are rechargeable.

When the auxiliary start receptacles are not available, use the following procedure.

1. Lower the equipment to the ground. Move all controls to the HOLD position. Move the hydraulic lockout control to the LOCKED position.
2. Turn the start switch on the stalled machine to the OFF position. Turn off all accessories.
3. Turn the battery disconnect switch on the stalled machine to the ON position.
4. Move the machine that is being used as an electrical source near the stalled machine so that the jump start cables reach the stalled machine. **Do not allow the machines to contact each other.**
5. Stop the engine of the machine that is being used as an electrical source. If you are using an auxiliary power source, turn off the charging system.
6. Ensure that battery caps on both machines are tight and correctly placed. Ensure that batteries in the stalled machine are not frozen. Make sure that the batteries have enough electrolyte.

Note: The positive terminal of the 24 volt system of the source and the negative terminal of the 24 volt system of the source must be identified correctly before the jumper cables are connected. The positive terminal of the 24 volt system of the discharged battery must be identified correctly before the jumper cables are connected.

7. The positive ends of the jump start cable are red. Connect one positive end of the jump start cable to the positive cable terminal of the discharged battery. Some machines have battery sets.

Note: Batteries that are in series may be in separate compartments. Use the terminal that is connected to the starter solenoid. This battery or battery set is normally on the same side of the machine as the starter.

Do not allow the positive cable clamps to contact any metal except for the battery terminals.

i02499459

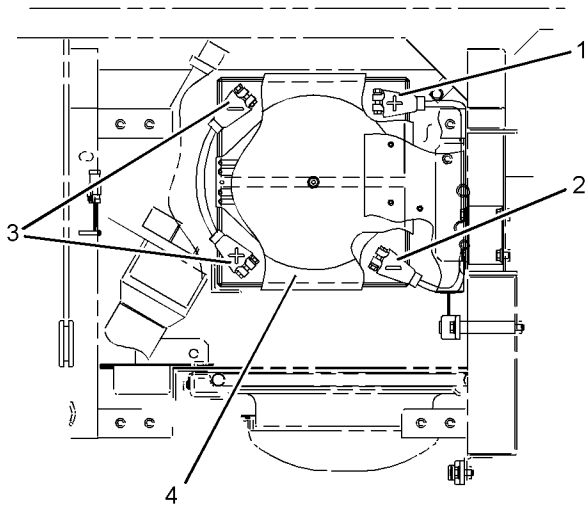

Illustration 341

g01226420

Typical example of the location of the batteries in an excavator

- (1) Red positive post to starter
- (2) The black negative post connects to the battery disconnect switch.
- (3) Do not use these two connections for jump starting. The red positive post is connected in series to the black negative post.
- (4) Cover

8. Connect the other positive end of the jump start cable to the positive cable terminal of the electrical source.
9. Connect one negative end of the jump start cable to the negative cable terminal of the electrical source.
10. Finally, connect the other negative end of the jump start cable to the frame of the stalled machine. Do not connect the jump start cable to the battery post. Do not allow the jump start cables to contact the battery cables, the fuel lines, the hydraulic lines, or any moving parts.
11. Start the engine of the machine that is being used as an electrical source or energize the charging system on the auxiliary power source.
12. Wait at least two minutes before you attempt to start the stalled machine. This will allow the batteries in the stalled machine to partially charge.
13. Attempt to start the stalled engine. See Operation and Maintenance Manual, "Engine Starting" for the correct starting procedure.
14. Immediately after you start the stalled engine, disconnect the jump start cables in reverse order.

Engine Starting with Auxiliary Start Receptacle

SMCS Code: 1000; 7000

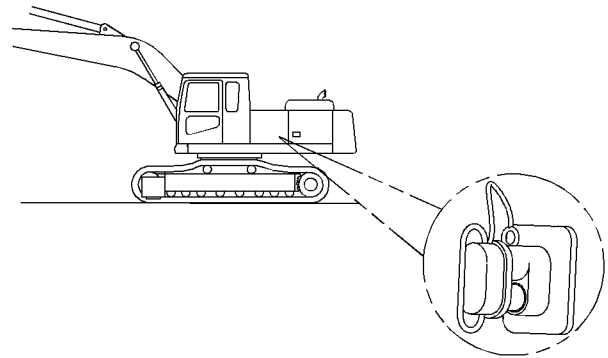

Illustration 342

g01122769

Typical location

Some Caterpillar products may be equipped with an auxiliary start receptacle as a standard part. If your machine is not equipped with an auxiliary start receptacle, the machine can be equipped with an auxiliary start receptacle from parts service. This will ensure that a permanent receptacle is always available in order to jump start the machine.

There are two cable assemblies that can be used to jump start the stalled machine. You can jump start the stalled machine from another machine that is equipped with an auxiliary start receptacle or with an auxiliary power pack. Your Caterpillar dealer can provide the correct cable lengths for your application.

1. Determine the reason that the engine will not start.
2. Move the transmission direction control lever on the stalled machine to NEUTRAL. Engage the hydraulic lockout control. Engage the parking brake. Lower all work tools to the ground. Move all controls to HOLD.
3. Turn the engine start switch key on the stalled machine to the OFF position. Turn off all accessories.
4. Turn the battery disconnect switch on the stalled machine to ON.
5. Move the machine that is being used as a power source close to the stalled machine. The jump start cables should reach the batteries on both machines. **DO NOT ALLOW THE MACHINES TO CONTACT EACH OTHER.**

- 6.** Stop the engine on the machine that is being used as a power source. If you use an auxiliary power source, turn off the charging system.
- 7.** Connect the appropriate jump start cable to the auxiliary start receptacle on the stalled machine.
- 8.** Connect the other end of the jump start cable to the auxiliary start receptacle of the machine that is being used as a power source.
- 9.** Start the engine on the machine that is being used as a power source or energize the charging system on the auxiliary power source.
- 10.** Wait for a minimum of two minutes while the batteries in the stalled machine partially charge.
- 11.** Attempt to start the stalled engine.
- 12.** Immediately after the stalled engine starts, disconnect the jump start cable from the power source.
- 13.** Disconnect the other end of the jump start cable from the stalled machine.
- 14.** Conclude the failure analysis on the starting charging system of the stalled machine, as required. Check the machine while the engine is running and the charging system is in operation.

Maintenance Section

Maintenance Access

i05969576

Access Door and Cover Locations

SMCS Code: 726A-CH

Engine Hood

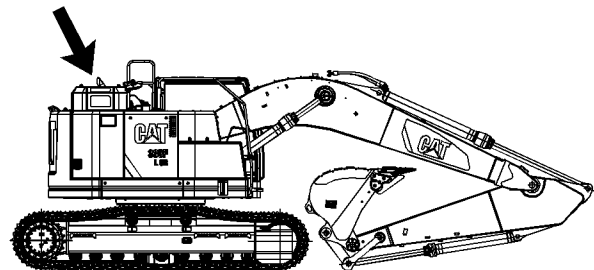

Illustration 343

g03742578

1. Unlatch the engine hood.

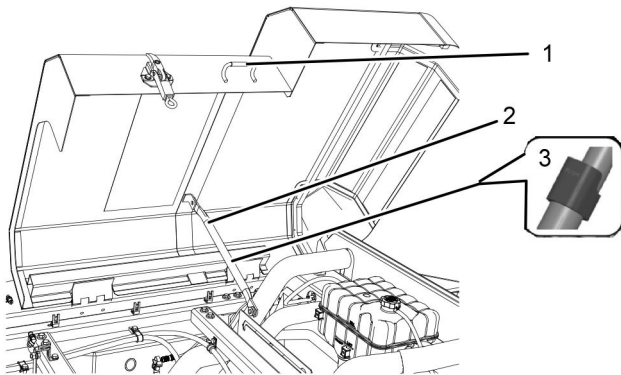

Illustration 344

g03388890

2. Use handle (1) in order to open the engine hood.
3. Fully open engine hood. Gas spring (2) will lock in place in order to hold the engine hood open.

⚠ WARNING

Operation of the Push Button Release for the Engine Hood

When closing the engine hood, only operate the push-button release by hand.

Failure to remove hands from the push-button release before closing the engine hood could result in personal injury.

Be sure to remove hands from the push-button release before completely closing the engine hood.

NOTICE

Do not add pressure to the engine hood when open.

⚠ WARNING

When closing the engine hood, Do Not operate the push-button release by foot.

Operation of the push-button release by foot could result in damage to the gas spring of the closing mechanism and/or personal injury.

Only operate the push-button release for closing the engine hood by hand.

4. In order to close the engine hood, support the engine hood with handle (1). press the push-button release(3) in order to unlock gas spring (2). Release the push button and slowly close the engine hood.

5. Latch the engine hood.

Left Access Door

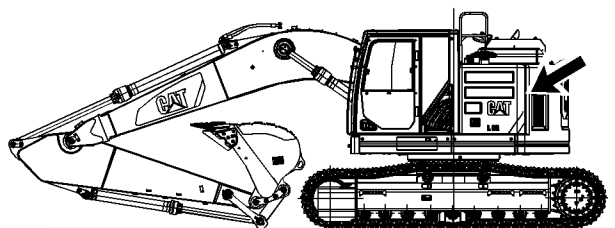

Illustration 345

g03742579

Right Access Door

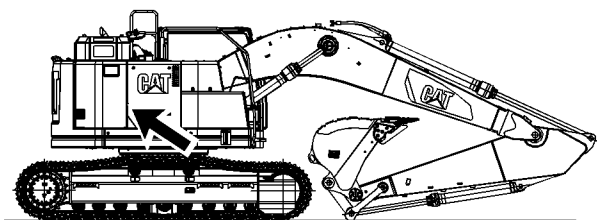

Illustration 346

g03742582

Lubricant Viscosities and Refill Capacities

i07419350

Lubricant Viscosities (Fluids Recommendations)

SMCS Code: 7581

General Information for Lubricants

When you are operating the machine in temperatures below -20°C (-4°F), refer to Special Publication, SEBU5898, "Cold Weather Recommendations". This publication is available from your Cat dealer.

Refer to the "Lubricant Information" section in the latest revision of the Special Publication, SEBU6250, "Caterpillar Machine Fluids Recommendations" for a list of Cat engine oils and for detailed information. This manual may be found on the web at Safety.Cat.com.

The footnotes are a key part of the tables. Read all footnotes that pertain to the machine compartment in question.

Selecting the Viscosity

To select the proper oil for each machine compartment, refer to the "Lubricant Viscosity for Ambient Temperature" table. Use the oil type AND oil viscosity for the specific compartment at the proper ambient temperature.

The proper oil viscosity grade is determined by the minimum ambient temperature (the air in the immediate vicinity of the machine). Measure the temperature when the machine is started and while the machine is operated. To determine the proper oil viscosity grade, refer to the "Min" column in the table. This information reflects the coldest ambient temperature condition for starting a cold machine and for operating a cold machine. Refer to the "Max" column in the table for operating the machine at the highest temperature that is anticipated. Unless specified otherwise in the "Lubricant Viscosities for Ambient Temperatures" tables, use the highest oil viscosity that is allowed for the ambient temperature.

Machines that are operated continuously should use oils that have the higher oil viscosity in the final drives and in the differentials. The oils that have the higher oil viscosity will maintain the highest possible oil film thickness. Refer to "General Information for Lubricants" article, "Lubricant Viscosities" tables, and any associated footnotes. Consult your Cat dealer if additional information is needed.

NOTICE

Not following the recommendations found in this manual can lead to reduced performance and compartment failure.

Engine Oil

Cat oils have been developed and tested to provide the full performance and life that has been designed and built into Cat engines.

Cat DEO-ULS or oils that meet the Cat ECF-3 specification, API CJ-4, and the newer API CK-4, are required for use in the applications listed below. Cat DEO-ULS and oils meeting Cat ECF-3 specification, API CJ-4, the newer API CK-4, and ACEA E9 oil categories have been developed with limited sulfated ash, phosphorus, and sulfur. These chemical limits are designed to maintain the expected aftertreatment devices life, performance, and service interval. If oils meeting the Cat ECF-3 specification, API CJ-4, the newer API CK-4 specifications are not available, oils meeting ACEA E9 may be used. ACEA E9 oils meet the chemical limits designed to maintain aftertreatment device life. ACEA E9 oils are validated using some but not all ECF-3 and API CJ-4 standard engine performance tests. Consult your oil supplier when considering use of an oil that is not Cat ECF-3, API CJ-4, or the newer API CK-4 qualified.

Failure to meet the listed requirements will damage aftertreatment-equipped engines and can negatively impact the performance of the aftertreatment devices. The Diesel Particulate Filter (DPF) if equipped, will plug sooner and require more frequent DPF ash service intervals.

Typical aftertreatment systems may include the following:

- Diesel Particulate Filters (DPF)
- Diesel Oxidation Catalysts (DOC)
- Selective Catalytic Reduction (SCR)
- Lean NOx Traps (LNT)

Other systems may apply.

Oils that are per API CI-4 or prior categories are not allowed. These oils have high ash and are not appropriate for use in engines with aftertreatment devices.

Table 50

Lubricant Viscosities for Ambient Temperatures						
Compartment or System	Oil Type and Performance Requirements	Oil Viscosities	°C		°F	
			Min	Max	Min	Max
Engine Crankcase for all Machines	Cat DEO-ULS Cold Weather	SAE 0W-40	-40	40	-40	104
	Cat DEO-ULS SYN	SAE 5W-40	-30	50	-22	122
	Cat DEO-ULS	SAE 10W-30	-18	40	0	104
		SAE 15W-40	-10	50	14	122
Pump Coupling (If Equipped)	Cat DEO-ULS	SAE 10W-30	-18	40	0	104

Hydraulic Systems

Refer to the “Lubricant Information” section in the latest revision of the Special Publication, SEBU6250, “Caterpillar Machine Fluids Recommendations” for detailed information. This manual may be found on the web at Safety.Cat.com.

The following are the preferred oils for use in most Cat machine hydraulic systems:

- Cat HYDO Advanced 10 SAE 10W
- Cat HYDO Advanced 20 SAE 20W
- Cat HYDO Advanced 30 SAE 30
- Cat BIO HYDO Advanced, Multigrade

Cat HYDO Advanced oils allow 6000 hours or higher oil drain intervals for most applications. S·O·S Services oil analysis is recommended when the oil drain interval is increased to 6000 hours or higher. In comparison, non-Cat commercial hydraulic oils (second choice oils) allow 2000 hours oil drain interval. It is recommended to follow the maintenance interval schedule for oil filter changes and for oil sampling that is stated in the Operation and Maintenance Manual for your particular machine. Consult your Cat dealer for details. When switching to Cat HYDO Advanced fluids, cross contamination with the previous oil should be kept to less than 10%.

Second choice oils are listed below.

- Cat MTO
- Cat DEO
- Cat DEO-ULS
- Cat TDTO
- Cat TDTO Cold Weather
- Cat TDTO-TMS
- Cat DEO-ULS Cold Weather

Note: Oil drain intervals of the oils listed above are less than those of Cat HYDO Advanced oils. The oil drain interval of these oils is typically 2000 hours and up to a maximum of 4000 hours. An exception is Cat TDTO Cold Weather oil which allows 6000 hours or higher oil drain interval. S·O·S Services oil analysis is required when the oils listed above are used in Cat hydraulic system components and hydrostatic transmissions.

Table 51

Lubricant Viscosities for Ambient Temperatures						
Compartment or System	Oil Type and Performance Requirements	Oil Viscosities	°C		°F	
			Min	Max	Min	Max
Hydraulic System	Cat HYDO Advanced 10 Cat TDTO	SAE 10W	-20	40	-4	104
	Cat HYDO Advanced 20 Cat TDTO	SAE 20W	-5	45	23	113
	Cat HYDO Advanced 30 Cat TDTO	SAE 30	10	50	50	122
	Cat BIO HYDO Advanced	"ISO 46" Multi-Grade	-30	50	-22	122
	Cat MTO Cat DEO-ULS Cat DEO	SAE10W-30	-20	40	-4	104
	Cat DEO-ULS Cat DEO	SAE15W-40	-15	50	5	122
	Cat TDTO-TMS	Multi-Grade	-15	50	5	122
	Cat DEO-ULS SYN	SAE 5W-40	-25	40	-13	104
	Cat DEO-ULS Cold Weather	SAE0W-40	-40	40	-40	104
	Cat TDTO Cold Weather	SAE 0W-20	-40	40	-40	104

For applications requiring the use of fire-resistant hydraulic fluids, Caterpillar recommends the use of EcoSafe FR-46. This product is a fully synthetic, non-aqueous hydraulic fluid. Water based and glycol-based hydraulic products are not recommended for use in Cat machine hydraulic systems. EcoSafe FR-46 is an ISO 46 multi-grade product. For more information refer to the product information provided by the manufacturer of EcoSafe hydraulic oil. Refer to your Cat dealer for availability.

Other Fluid Applications

Table 52

Excavators, Front Shovels, Mass Excavators, Demolition Excavators, and Track Material Handlers Lubricant Viscosities for Ambient Temperatures						
Compartment or System	Oil Type and Performance Requirements	Oil Viscosity Grade	°C		°F	
			Min	Max	Min	Max
Final Drives and Swing Drives	Cat TDTO Cold Weather	SAE 0W-20	-40	0	-40	32
	Cat TDTO	SAE 10W	-30	0	-22	32
		SAE 30 ⁽¹⁾	-30	35	-22	95
		SAE 50	-15	50	5	122
	Cat TDTO-TMS	Multi-Grade	-25	25	-13	77
Track Roller Frame Recoil Spring and Pivot Shaft Bearings	Cat TDTO Cold Weather	SAE 0W-20	-40	0	-40	32
	Cat TDTO	SAE 10W	-30	0	-22	32
		SAE 30 ⁽¹⁾	-20	25	-4	77

(continued)

(Table 52, contd)

Excavators, Front Shovels, Mass Excavators, Demolition Excavators, and Track Material Handlers Lubricant Viscosities for Ambient Temperatures						
Compartment or System	Oil Type and Performance Requirements	Oil Viscosity Grade	°C		°F	
			Min	Max	Min	Max
		SAE 50	0	50	32	122
	Cat TDTO-TMS	Multi-Grade	-25	25	-13	77
Track Idlers and Track Rollers	Cat DEO-ULS Cat DEO	SAE 15W-40 ⁽¹⁾	-10	50	14	122
	Cat DEO Cold Weather	SAE 0W-40	-40	40	-40	104
	Cat DEO-ULS SYN	SAE 5W-40	-35	40	-31	104
	Cat FDAO SYN	Multi-Grade	-30	50	-22	122

⁽¹⁾ Factory fill oil for standard configuration machines.

Special Lubricants

Grease

To use a non-Cat grease, the supplier must certify that the lubricant is compatible with Cat grease.

Each pin joint should be flushed with the new grease. Ensure that all old grease is removed. Failure to meet this requirement may lead to failure of a pin joint.

Table 53

Recommended Grease						
Compartment or System	Grease Type	NLGI Grade	°C		°F	
			Min	Max	Min	Max
External Lubrication Points	Cat Prime Application Grease	NLGI Grade 2	-20	140	-4	284
	Cat Extreme Application Grease	NLGI Grade 1	-20	140	-4	284
		NLGI Grade 2	-15	140	+5	284
	Cat Extreme Application Grease-Artic	NLGI Grade 0.5	-50	130	-58	266
	Cat Extreme Application Grease-Desert	NLGI Grade 2	-10	140	+14	284
	Cat Utility Grease	NLGI Grade 2	-20	140	-4	284
	Cat Ball Bearing Grease	NLGI Grade 2	-20	160	-4	320

Diesel Fuel Recommendations

Diesel fuel must meet Caterpillar Specification for Distillate Fuel and the latest revisions of "ASTM D975" and "EN 590" to ensure optimum engine performance. Refer to Special Publication, SEBU6250, "Caterpillar Machine Fluids Recommendations" for the latest fuel information and for Cat fuel specification. This manual may be found on the Web at Safety.Cat.com.

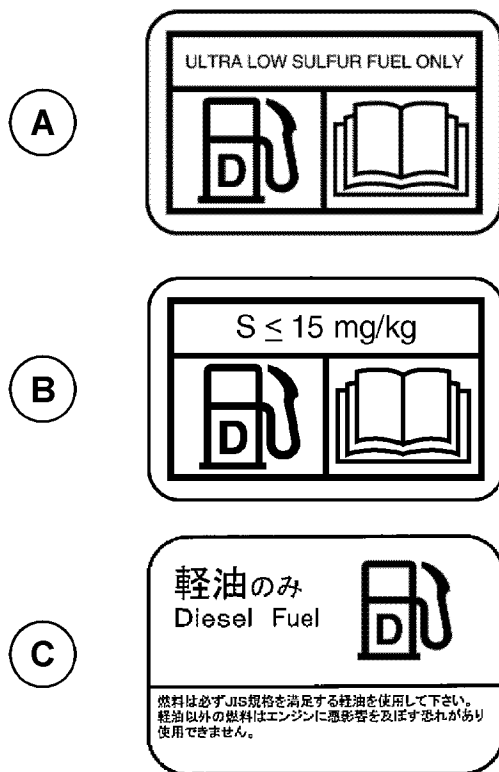

Illustration 347

g03218956

(A) North America film
(B) Europe, Africa, Middle East film
(C) Japan film

NOTICE

Ultra Low Sulfur Diesel (ULSD) fuel 0.0015 percent (≤ 15 ppm (mg/kg)) sulfur is required by regulation for use in engines certified to nonroad Tier 4 standards (U. S. EPA Tier 4 certified) and that are equipped with exhaust aftertreatment systems.

European ULSD 0.0010 percent (≤ 10 ppm (mg/kg)) sulfur fuel is required by regulation for use in engines certified to European Stage V type-approved nonroad engines. Additionally, the Cetane number should not be less than 45, and the bio-diesel content should not be greater than 20% volume/volume.

Misfueling with fuels of higher sulfur level can have the following negative effects:

- Shorten the time interval between aftertreatment device service intervals (cause the need for more frequent service intervals)
 - Adversely impact the performance and life of aftertreatment devices (cause loss of performance)
 - Reduce regeneration intervals of aftertreatment devices
- Reduce engine efficiency and durability.
 - Increase the wear.
 - Increase the corrosion.
 - Increase the deposits.
 - Lower fuel economy
 - Shorten the time period between oil drain intervals (more frequent oil drain intervals).
 - Increase overall operating costs.

Failures that result for the use of improper fuels are not Caterpillar factory defects. Therefore, the cost of repairs would not be covered by a Caterpillar warranty.

Caterpillar does not require the use of ULSD in non-road and machine applications that are not Tier 4/ Stage V certified engines and are not equipped with aftertreatment devices. For Tier 4/Stage V certified engines, always follow operating instructions to ensure that the correct fuels are used.

Refer to Special Publication, SEBU6250, "Caterpillar Machine Fluids Recommendations" for more details about fuels, lubricants, and Tier 4/Stage V requirements. This manual may be found on the web at Safety.Cat.com.

Diesel Exhaust Fluid**General Information**

Diesel Exhaust Fluid (DEF) is a liquid that is injected into the exhaust system of engines equipped with Selective Catalytic Reduction (SCR) systems. SCR reduces emissions of nitrogen oxides (NOx) in diesel engine exhaust.

Diesel Exhaust Fluid (DEF) is also known under other names including Aqueous Urea Solution (AUS) 32, AdBlue, or generically referred to as urea.

In engines equipped with SCR emissions reduction system, DEF is injected in controlled amounts into the engine exhaust stream. At the elevated exhaust temperature, urea in DEF is converted to ammonia. The ammonia chemically reacts with NOx in diesel exhaust in the presence of the SCR catalyst. The reaction converts NOx into harmless nitrogen (N₂) and water (H₂O).

DEF Recommendations

For use in Cat engines, DEF must meet all the requirements defined by "ISO 22241-1" Requirements.

Caterpillar recommends the use of DEF available through the Cat parts ordering system for use in Cat engines equipped with SCR systems.

In North America, commercial DEF that is API approved and meets all the requirements defined in "ISO 22241-1" may be used in Cat engines that are equipped with SCR systems.

Outside of North America, commercial DEF that meets all requirements defined in "ISO 22241-1" may be used in Cat engines that are equipped with SCR systems.

The supplier should provide documentation to prove that the DEF is compliant with the requirements of "ISO 22241-1".

NOTICE

Cat does not warrant the quality or performance of non-Cat fluids.

NOTICE

Do not use agriculture grade urea solutions. Do not use any fluids that do not meet "ISO 22241-1" Requirements in SCR emissions reduction systems. Use of these fluids can result in numerous problems including damage to SCR equipment and a reduction in NOx conversion efficiency.

DEF is a solution of solid urea that is dissolved in demineralized water to produce a final concentration of 32.5% urea. DEF concentration of 32.5% is optimal for use in SCR systems. DEF solution of 32.5% urea has the lowest attainable freeze point of -11.5° C (11.3° F). DEF concentrations that are higher or lower than 32.5% have higher freeze points. DEF dosing systems and "ISO 22241-1" specifications are designed for a solution that is approximately 32.5%.

Caterpillar offers a refractometer, Cat part number 360-0774, that can be used to measure DEF concentration. Follow the instructions provided with the instrument. Appropriate commercial portable refractometers can be used to determine urea concentration. Follow the instructions from the manufacturer.

DEF Guidelines

DEF solution is typically colorless and clear. Changes to color or clarity are indicators of quality issues. Quality of DEF can degrade when stored and handled inappropriately or if DEF is not protected from contamination. Details are provided below.

If quality issues are suspected, testing of DEF should focus on urea percentage, alkalinity as NH₃ and biuret content. DEF that does not pass all these tests or that is no longer clear should not be used.

Materials compatibility

DEF is corrosive. Due to the corrosion caused, DEF must be stored in tanks constructed of approved materials. Recommended storage materials:

Stainless Steels:

- 304 (S30400)
- 304L (S30403)
- 316 (S31600)
- 316L (S31603)

Alloys and metals:

- Chromium Nickel (CrNi)
- Chromium Nickel Molybdenum (CrNiMo)
- Titanium

Non-metallic materials:

- Polyethylene
- Polypropylene
- Polyisobutylene
- Teflon (PFA)
- Polyfluoroethylene (PFE)
- Polyvinylidene fluoride (PVDF)
- Polytetrafluoroethylene (PTFE)

Materials NOT compatible with DEF solutions include Aluminum, Magnesium, Zinc, Nickel coatings, Silver and Carbon steel, and Solders containing any of the above. Unexpected reactions may occur if DEF solutions come in contact with any non-compatible material or unknown materials.

Bulk storage

Follow all local regulations covering bulk storage tanks. Follow proper tank construction guidelines. Tank volume typically should be 110% of planned capacity. Appropriately vent indoor tanks. Plan for control of overflow of the tank. Heat tanks that dispense DEF in cold climates.

Bulk tank breathers should be fitted with filtration to keep airborne debris from entering the tank. Desiccant breathers should not be used because water will be absorbed, which potentially can alter DEF concentration.

Handling

Follow all local regulations covering transport and handling. DEF transport temperature is recommended to be -5° C (23° F) to 25° C (77° F). All transfer equipment and intermediate containers should be used exclusively for DEF. Containers should not be reused for any other fluids. Ensure that transfer equipment is made from DEF-compatible materials. Recommended material for hoses and other non-metallic transfer equipment includes:

- Nitrile Rubber (NBR)
- Fluoroelastomer (FKM)
- Ethylene Propylene Diene Monomer (EPDM)

The condition of hoses and other nonmetallics that are used with DEF should be monitored for signs of degradation. DEF leaks are easily recognizable by white urea crystals that accumulate at the site of the leak. Solid urea can be corrosive to galvanized or unalloyed steel, aluminum, copper, and brass. Leaks should be repaired immediately to avoid damage to surrounding hardware.

Cleanliness

Contaminants can degrade the quality and life of DEF. Filtering DEF is recommended when dispensed into the DEF tank. Filters should be compatible with DEF and should be used exclusively with DEF. Check with the filter supplier to confirm compatibility with DEF before using. Mesh-type filters using compatible metals, such as stainless steel, are recommended. Paper (cellulose) media and some synthetic filter media are not recommended because of degradation during use.

Care should be taken when dispensing DEF. Spills should be cleaned immediately. Machine or engine surfaces should be wiped clean and rinsed with water. Caution should be used when dispensing DEF near an engine that has recently been running. Spilling DEF onto hot components will cause harmful vapors.

Stability

NOTICE

Storing Diesel Exhaust Fluid in high heat areas is not recommended. Do not store DEF in high heat generating areas on the machine, such as the pump compartment or the engine compartment. The quality of the DEF can degrade when exposed to high temperatures.

DEF fluid is stable when stored and handled properly. The quality of DEF rapidly degrades when stored at high temperatures. The ideal storage temperature for DEF is between -9°C (15.8°F) and 25°C (77°F). DEF that is stored above 35°C (95°F) for longer than 1 month must be tested before use. Testing should evaluate Urea Percentage, Alkalinity as NH_3 and Biuret content.

The length of storage of DEF is listed in the following table:

Table 54

Storage Temperature	Expected DEF Life
Below 25°C (77°F)	18 months
25°C (77°F) to 30°C (86°F)	12 months
30°C (86°F) to 35°C (95°F)	6 months
Above 35°C (95°F)	test quality before use

Refer to “ISO 22241” document series for more information about DEF quality control.

Note: Dispose of all fluids according to applicable regulations and mandates.

Fuel Additives

Cat Diesel Fuel Conditioner and Cat Fuel System Cleaner are available for use when needed. These products are applicable to diesel and biodiesel fuels. Consult your Cat dealer for availability.

Biodiesel

Biodiesel is a fuel that can be made from various renewable resources that include vegetable oils, animal fat, and waste cooking oil. Soybean oil and rapeseed oil are the primary vegetable oil sources. To use any of these oils or fats as fuel, the oils, or fats are chemically processed (esterified). The water and contaminants are removed.

U.S. distillate diesel fuel specification “ASTM D7467” includes up to B20 (20 percent) biodiesel. Any diesel fuel in the U.S. may contain up to B20 biodiesel fuel.

European distillate diesel fuel specification “EN16709:2015” includes up to B20 (20 percent) biodiesel. Any diesel fuel in Europe may contain up to B20.

Note: The diesel portion used in the biodiesel blend must be Ultra Low Sulfur Diesel (15 ppm sulfur or less, per “ASTM D975”). In Europe the diesel fuel portion used in the biodiesel blend must be sulfur free diesel (10 ppm sulfur or less, per “EN 590”). The final blend must have 15 ppm sulfur or less.

When biodiesel fuel is used, certain guidelines must be followed. Biodiesel fuel can influence the engine oil, aftertreatment devices, non-metallic, fuel system components, and others. Biodiesel fuel has limited storage life and has limited oxidation stability. Follow the guidelines and requirements for engines that are seasonally operated.

To reduce the risks associated with the use of biodiesel, the final biodiesel blend and the biodiesel fuel used must meet specific blending requirements.

All the guidelines and requirements are provided in the latest revision of Special Publication, SEBU6250, "Caterpillar Machine Fluids Recommendations". This manual may be found on the web at Safety.Cat.com.

Coolant Information

The information provided in this "Coolant Recommendation" section should be used with the "Lubricants Information" provided in the latest revision of Special Publication, SEBU6250, "Caterpillar Machine Fluids Recommendations". This manual may be found on the web at Safety.Cat.com.

The following two types of coolants may be used in Cat diesel engines:

Preferred – Cat ELC (Extended Life Coolant)

Acceptable – Cat DEAC (Diesel Engine Antifreeze/Coolant)

NOTICE

Never use water alone as a coolant. Water alone is corrosive at engine operating temperatures. In addition, water alone does not provide adequate protection against boiling or freezing.

Table 55

Recommendations for Finished Coolants for use in Cat engines				
Coolant Type	Recommendations	Product	Service hours ⁽¹⁾⁽²⁾	Required Maintenance ⁽³⁾
Cat ELC, Cat ELI, or commercial coolant that meets Cat EC-1	Preferred	Cat ELC	12000 hours or 6 years	Add Cat ELC Extender at 6000 service hours or one half of service life
		Cat ELI (water based) ⁽⁴⁾	12000 hours or 6 years	Add Cat ELC Extender at 6000 service hours or one half of service life
	Min requirements	Cat EC-1 specification and "ASTM D6210" and Organic Additive Technology (OAT) based on a combination of a monocarboxylic acid and a dicarboxylic acid. Free of phosphate, borate, and silicate. Tolyltriazole: minimum typical concentration of 900 ppm Nitrite: minimum typical concentration of 500 ppm in new coolants	6000 hours or 6 years	Add Extender at 3000 service hours or one half of service life
Cat DEAC, Cat SCA, conventional coolants, and commercial extended life coolants that do not meet EC-1	Acceptable	Cat DEAC	3000 hours or 3 years	SCA at maintenance intervals
		Cat SCA (water based) ⁽⁴⁾	3000 hours or 2 years	SCA at maintenance intervals

(continued)

Maintenance Section
Capacities (Refill)

(Table 55, contd)

Recommendations for Finished Coolants for use in Cat engines				
	Min requirements for fully formulated Heavy-Duty Commercial coolants	"ASTM D6210" and Nitrite (as NO ₂) concentration: Minimum of 1200 ppm (70 grains/US gal) and maximum of 2400 ppm (140 grains/US gal) Silicon concentration: minimum of 100 ppm and maximum of 275 ppm	3000 hours or 2 years	SCA at maintenance intervals
	Min requirements for SCA and water ⁽⁴⁾ ⁽⁵⁾	Commercial supplemental coolant additive and water having Nitrite (as NO ₂) concentration: Minimum of 1200 ppm (70 grains/US gal) and maximum of 2400 ppm (140 grains/US gal) Silicon concentration: minimum of 100 ppm and maximum of 275 ppm	3000 hours or 1 year	Per manufacturer recommendations

- (1) New Coolants at 50 volume percent diluted. Coolants that are prediluted at the coolant manufacturer must be diluted with water that meets Reagent 4 "ASTM D1193" requirements.
- (2) Maintain the in-service coolant at the given limits.
- (3) For appropriate maintenance procedures, refer to the details given in this Chapter. For applications that allow the use of Cat ELI in water, a minimum of 7.5 percent of Cat ELI is recommended. For applications that allow the use of SCA and water, a minimum of 6 percent to a maximum of 8 percent concentration of Cat SCA are recommended.
- (4) Water-based coolants are not allowed for use in machines that has NO_x reduction aftertreatment devices, in engines that has AATAC and in Marine engines that have SWAC
- (5) There are currently no industry standards to define the quality of water-based conventional coolants. To control the quality of SCA and water coolants, the commercial SCA additive package should pass ASTM D6210 when this package is used in a glycol-based coolant. Do not use a commercial SCA additive package that only meets the ASTM D3306 or equivalent specification when used in a glycol-based coolant.

i06837880

Capacities (Refill)

SMCS Code: 1000; 7000

Table 56

Approximate Refill Capacities			
Component or System	Liters	US gal	Recommended Type
Cooling System	44	12	Refer to Operation and Maintenance Manual, "Lubricant Viscosities".
Coolant Reservoir	4.5	1.2	
Fuel Tank	385	102	
Engine Crankcase with Filter	23	6.0	
Hydraulic System ⁽¹⁾	154	40.5	
Swing Drive	9	2.5	
Each Final Drive	8	2.1	
DEF Tank	23	6.1	
	kg	lbs	

(continued)

(Table 56, contd)

Approximate Refill Capacities			
Component or System	Liters	US gal	Recommended Type
Swing Gear	14.9	33	Refer to Operation and Maintenance Manual, "Lubricant Viscosities".
Refrigerant ⁽²⁾	1	2.2	R-134a
	mL	oz	
Refrigerant Oil ⁽²⁾	240	8.2	Polyalkylene Glycol (PAG) Oil

(1) The amount of hydraulic fluid that is needed to refill the hydraulic system after performing Operation and Maintenance Manual, "Hydraulic System Oil - Change"

(2) Refer to Service Manual, "Air Conditioning and Heating R-134a for All Caterpillar Machines" for additional information

i07445339

S·O·S Information

SMCS Code: 1000; 1348; 3080; 4050; 5050; 7000; 7542-008

S·O·S Services is a highly recommended process for Cat customers to use in order to minimize owning and operating cost. Customers provide oil samples, coolant samples, and other machine information. The dealer uses the data in order to provide the customer with recommendations for management of the equipment. In addition, S·O·S Services can help determine the cause of an existing product problem.

Refer to Special Publication, SEBU6250, "Caterpillar Machine Fluid Recommendations" for detailed information concerning S·O·S Services.

The effectiveness of S·O·S Services is dependent on timely submission of the sample to the laboratory at recommended intervals.

Refer to the Operation and Maintenance Manual, "Maintenance Interval Schedule" for a specific sampling location and a service hour maintenance interval.

Consult your Cat dealer for complete information and assistance in establishing an S·O·S program for your equipment.

Maintenance Support

i05247392

Service Interval Chart

SMCS Code: 7000

The service interval chart is located inside the cab and on the window.

Refer to this Operation and Maintenance Manual, "Maintenance Interval Schedule" for the correct maintenance intervals and procedures that are specific to your machine.

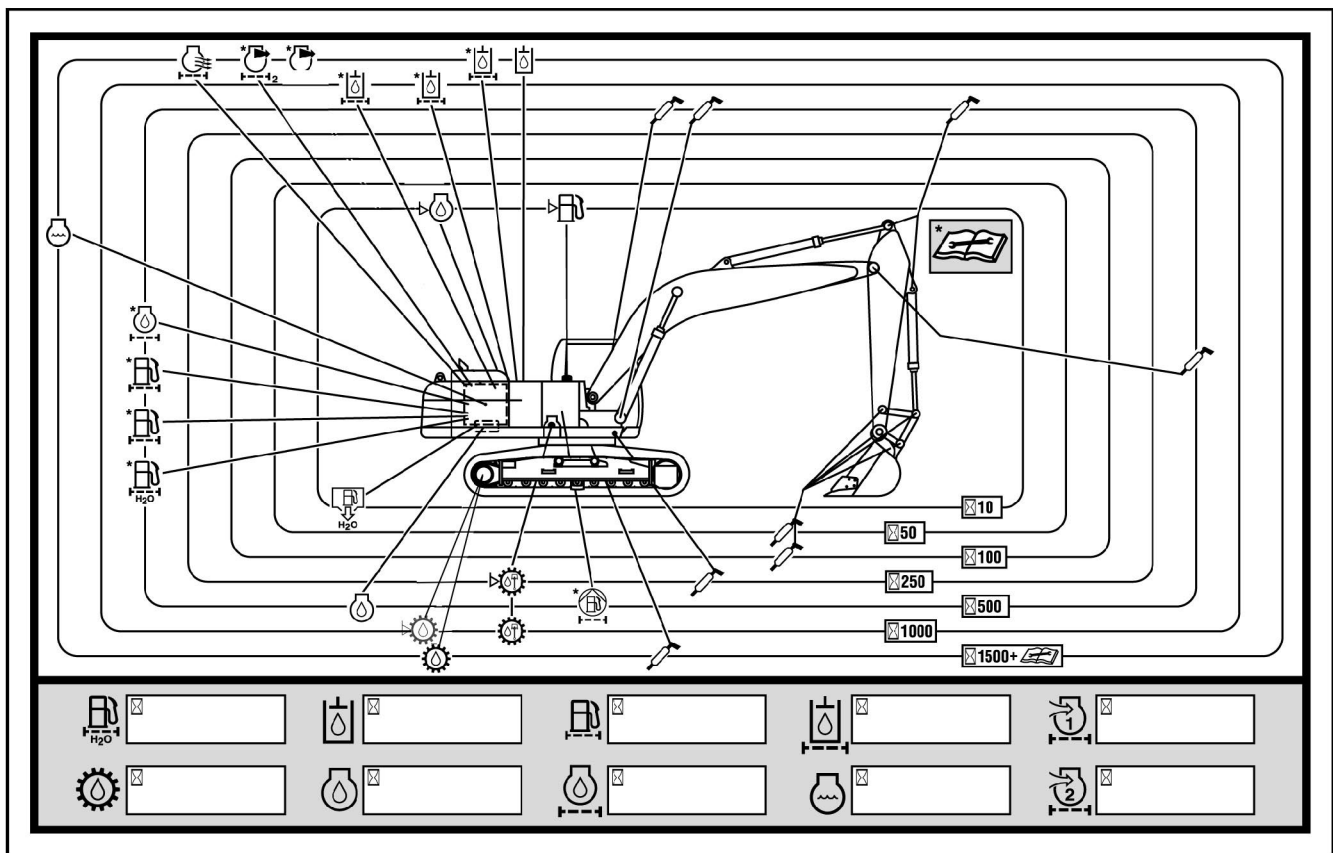

Illustration 348

g03344929

Typical example of a service interval chart



Service hour interval – Hourly interval in which a maintenance procedure should be performed.



Cooling system coolant – Change the ELC (Extended Life Coolant) .



Coolant level – Check the coolant level.



Engine air filter primary element – Clean or replace the primary air filter element.

i07327201



Engine air filter secondary element –
Replace the secondary air filter element.



Engine oil level – Check the engine oil level.



Engine oil – Change the engine oil.



Engine oil filter – Change the engine oil filter.



Final drive oil level – Check the final drive oil level.



Final drive oil – Change the final drive oil.



Fuel level – Check the fuel level.



Fuel system filter – Replace the fuel system filters.



Fuel system water separator – Drain the water separator.



Fuel system water separator element –
Replace the fuel system water separator element.



Fumes Disposal Filter Element –
Replace the fumes disposal filter element.



Grease zerk – Lubricate the designated locations.



Hydraulic oil level – Check the hydraulic oil level.



Hydraulic oil – Change the hydraulic oil.



Hydraulic oil filter – Change the hydraulic oil filter.



Swing drive oil level – Check the swing drive oil level.



Swing drive oil – Change the swing drive oil.

System Pressure Release

SMCS Code: 1250-553-PX; 1300-553-PX; 1350-553-PX; 5050-553-PX; 6700-553-PX; 7540-553-PX

WARNING

Personal injury or death can result from sudden machine movement.

Sudden movement of the machine can cause injury to persons on or near the machine.

To prevent injury or death, make sure that the area around the machine is clear of personnel and obstructions before operating the machine.

Coolant System

WARNING

Pressurized system: Hot coolant can cause serious burn. To open cap, stop engine, wait until radiator is cool. Then loosen cap slowly to relieve the pressure.

To relieve the pressure from the coolant system, turn off the machine. Allow the cooling system pressure cap to cool. Remove the cooling system pressure cap slowly to relieve pressure.

Hydraulic System

The release of hydraulic pressure in a hydraulic circuit is required before service is performed to that hydraulic circuit. Release the pressure in the following hydraulic circuits before any service associated with that hydraulic circuit is performed.

- Boom hydraulic circuit
- Stick hydraulic circuit
- Bucket hydraulic circuit
- Swing hydraulic circuit
- Travel hydraulic circuit
- Attachment hydraulic circuits (if equipped)
- Pilot hydraulic circuit
- Return hydraulic circuit

Note: Refer to the Disassembly and Assembly Manual for additional information concerning service of the components of specific hydraulic circuits.

Release of Hydraulic Pressure from the Main Hydraulic System

WARNING

Personal injury can result from hydraulic oil pressure and hot oil.

Hydraulic oil pressure can remain in the hydraulic system after the engine has been stopped. Serious injury can be caused if this pressure is not released before any service is done on the hydraulic system.

Make sure all of the work tools have been lowered to the ground, and the oil is cool before performing any service. Remove the oil filler cap only when the engine is stopped, and the filler cap is cool enough to touch with your bare hand.

NOTICE

Care must be taken to ensure that fluids are contained during performance of inspection, maintenance, testing, adjusting, and repair of the product. Be prepared to collect the fluid with suitable containers before opening any compartment or disassembling any component containing fluids.

Refer to Special Publication, PERJ1017, "Dealer Service Tool Catalog" for tools and supplies suitable to collect and contain fluids on Cat® products.

Dispose of all fluids according to local regulations and mandates.

Perform the following steps to release the hydraulic system pressure from the main hydraulic system. For information on any fluids and capacities, refer to this Operation and Maintenance Manual, "Lubricant Viscosities" and "Capacities (Refill)" for more information.

Note: For additional safety, wrap hydraulic joint with material that could absorb/reduce any residual pressure of oil when released. Loosen the joint slowly, pause, and carefully check hydraulic joint for tensions indicating presence of pressure or spring force in lines or components.

1. Position the machine on level ground.

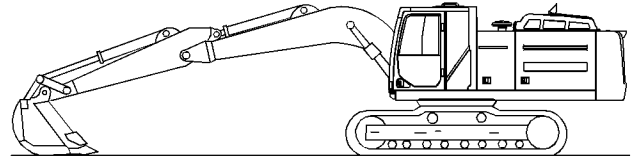

Illustration 349

g02137969

2. Fully retract the stick cylinder rod. Adjust the position of the linkage so that the work tool is parallel to the ground. Lower the boom until the work tool is flat on the ground. Refer to Illustration 349.

3. Release the system pressure from the implement and swing hydraulic circuits.

a. Shut off the engine.

Note: Perform Step 3b through Step 3d immediately after the engine is shut off to insure adequate pilot system pressure is available to release the pressure in the hydraulic circuits.

b. Turn the engine start switch to the ON position without starting the engine.

c. Place the hydraulic activation control lever in the UNLOCKED position.

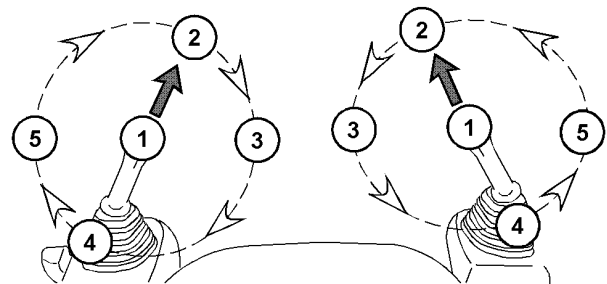

Illustration 350

g03315377

d. Move both joysticks in a circular motion to the FULL STROKE positions multiple times until the pilot accumulator has been exhausted.

Note: Pilot pressure is required to relieve hydraulic system pressure.

- e. Place the hydraulic activation control lever in the LOCKED position.
- f. Start the engine to recharge pilot accumulator.
- g. Shut off the engine.
- h. Repeat Step 3b through Step 3g until the high-pressure lines have been released.

Note: Do not activate any levers when recharging pilot accumulator.

Each time the accumulator is recharged, start the joysticks at different positions or rotate in the reverse direction. Doing so will ensure that the same circuit is not being relieved each time.

Note: Pressure could build on these circuits after pressure is released due to linkage settling or bucket rolling.

Note: To release pressure in a single circuit, move the joysticks or pedals of the hydraulic circuit that requires service to the full stroke positions after moving joysticks in a circular motion. Moving the joysticks or pedals to the full stroke position will release the high pressure only in that single hydraulic circuit. Moving the joysticks or pedals to the full stroke position will also release any pressure that might be present in the pilot hydraulic circuit.

4. Release hydraulic system pressure in the attachment circuits, if equipped.

- a. Start the engine to charge pilot accumulator.
- b. Shut off the engine.

Note: Perform Step 4c through Step 4e immediately after the engine is shut off to insure adequate pilot system pressure is available to release the pressure in the hydraulic circuits.

- c. Turn the engine start switch to the ON position without starting the engine.
- d. Place the hydraulic activation control lever in the UNLOCKED position.
- e. Activate the switch or pedal for the attachment circuit.
- f. Place the hydraulic activation control lever in the LOCKED position.
- g. Start the engine to recharge pilot accumulator.

Note: Do not activate any pedals or switches when recharging pilot accumulator.

- h. Shut off the engine.

- i. Repeat Step 4a through Step 4h for each attachment circuit.

5. After releasing the hydraulic pressure in each of the desired hydraulic circuits, place the hydraulic activation control lever in the LOCKED position.

6. Turn the engine start switch to the OFF position.

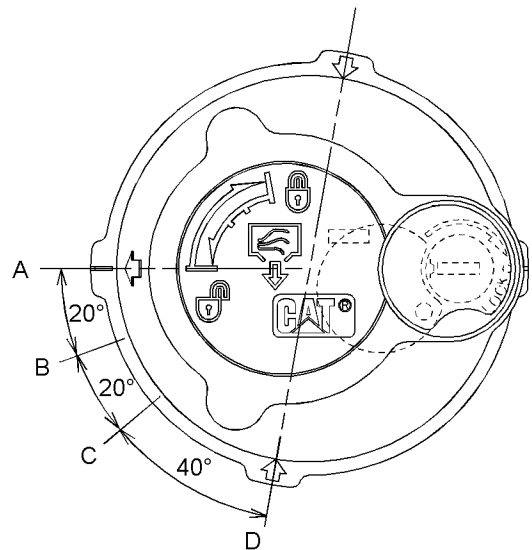

Illustration 351

g02275615

Filler cap

- (A) LOCK position
- (B) PRESSURE RELEASE - START position
- (C) PRESSURE RELEASE - END position
- (D) OPEN position

7. Release the pressure that may be present in the return hydraulic circuit with the following procedure. Refer to Illustration 351 for filler cap positions.

- a. Turn the filler cap counterclockwise and move the arrow from position (A) to position (B).
- b. Release the pressure for a minimum of 45 seconds by moving the arrow from position (B) to position (C).
- c. Push down the filler cap and move the arrow from position (C) to position (D).

Note: The travel hydraulic circuit is open to the hydraulic tank. Pressure from the travel circuit is released by releasing pressure from the return circuit.

8. Release the pressure that may be present in the boom circuit to remove the risk of residual pressure in the line. Make sure that the engine start switch is in the OFF position and the pressure in the hydraulic tank has been released.

For machines equipped with a boom lowering control valve, there is a manual valve located near the base of the boom or a valve on the load control valve on the boom cylinder. Refer to Operation and Maintenance Manual, Equipment Lowering with Engine Stopped Machine with a Boom Lowering Control Valve for more information.

For machines **NOT** equipped with a boom lowering control valve, refer to Operation and Maintenance Manual, Equipment Lowering with Engine Stopped Machine without a Boom Lowering Control Valve for more information.

- a. Connect one end of a drain hose to purge screw (6). Insert the other end of the drain hose into an empty container.
- b. Loosen purge screw (6) by 1/2 turn. Hydraulic oil will be drained from the drain hose to the container.

Note: Dispose of drained fluid according to local regulations.

- c. Tighten purge screw (6) to a torque of 13 +/- 2 Nm (9 +/- 1 lb ft) after all the hydraulic oil has been drained from the line.
- d. Repeat Steps 9a through 9c for all circuits.
- e. Remove the drain hose and install hydraulic tank fill cap.

10. The pressure in the multiple hydraulic circuits that require service is now released and lines and components can be disconnected or removed from those hydraulic circuits.

i07746333

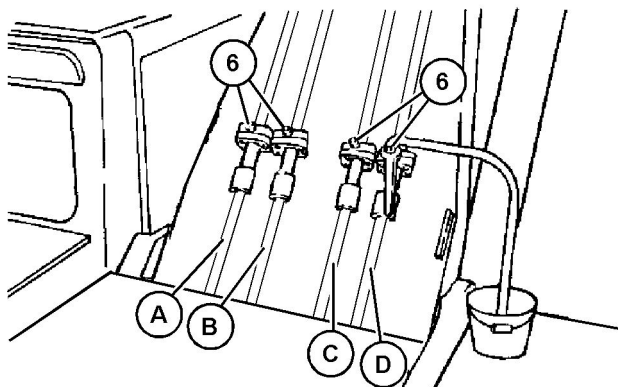

Illustration 352 g06234927

Stick and Bucket circuit locations

- (6) Purge Screws (If Equipped)
- (A) Circuit A
- (B) Circuit B
- (C) Circuit C
- (D) Circuit D

9. If the purge screws are equipped, perform the following pressure release procedure for each Stick and Bucket circuit. Refer to Illustration 352 and Table 57 for the stick and bucket circuit locations.

Table 57

Stick and Bucket Circuit Locations				
Sales Model	Circuits			
	A	B	C	D
326 / 329 / 330	Stick In	None	Stick Out	None
336 / 340	Bucket Close	Stick In	Stick Out	Bucket Open
349 / 352	Stick Out	Stick In	Bucket Close	Bucket Open

Welding on Machines and Engines with Electronic Controls

SMCS Code: 1000; 7000

Do not weld on any protective structure. If it is necessary to repair a protective structure, contact your Cat dealer.

Proper welding procedures are necessary to avoid damage to the electronic controls and to the bearings. When possible, remove the component that must be welded from the machine or the engine and then weld the component. If you must weld near an electronic control on the machine or the engine, temporarily remove the electronic control to prevent heat related damage. The following steps should be followed to weld on a machine or an engine with electronic controls.

1. Turn off the engine. Place the engine start switch in the OFF position.
2. If equipped, turn the battery disconnect switch to the OFF position. If there is no battery disconnect switch, remove the negative battery cable at the battery.

NOTICE

Do NOT use electrical components (ECM or sensors) or electronic component grounding points for grounding the welder.

3. Clamp the ground cable from the welder to the component that will be welded. Place the clamp as close as possible to the weld. Make sure that the electrical path from the ground cable to the component does not go through any bearing. Use this procedure to reduce the possibility of damage to the following components:
 - Bearings of the drive train
 - Hydraulic components
 - Electrical components
 - Other components of the machine
4. Protect any wiring harnesses and components from the debris and the spatter which is created from welding.
5. Use standard welding procedures to weld the materials together.

i04807435

Severe Service Application

SMCS Code: 1000

An engine which operates outside of normal conditions is operating in a severe service application.

An engine that operates in a severe service application may need more frequent maintenance intervals in order to maximize the following conditions:

- Reliability
- Service life

The number of individual applications cause the impossibility of identifying all of the factors which may contribute to severe service operation. Consult your Caterpillar dealer for the unique maintenance that may be necessary for your engine.

An application is a severe service application if any of the following conditions apply:

Severe Environmental Factors

- Frequent operation in dirty air
- Frequent operation at an altitude which is above 1525 m (5000 ft)
- Frequent operation in ambient temperatures which are above 32° C (90° F)

- Frequent operation in ambient temperatures which are below 0° C (32° F)

Severe Operating Conditions

- Frequent operation with inlet air which has a corrosive content
- Operation with inlet air which has a combustible content
- Operation which is outside of the intended application
- Operation with a plugged fuel filter
- Extended operation at low idle (more than 20% of hours)
- Frequent cold starts at temperatures below 0° C (32° F)
- Frequent dry starts (starting after more than 72 hours of shutdown)
- Frequent hot shutdowns (shutting down the engine without the minimum of 2 minutes to 5 minutes of cool down time)
- Operation above the engine rated speed
- Operation below the peak torque speed
- Operating with fuel which does not meet the standards for distillate diesel fuel as stated in Special Publication, SEBU6250, "Caterpillar Machine Fluids Recommendations" "Distillate Diesel Fuel"
- Operating with a blend of distillate fuel which contains more than 20 percent biodiesel

Improper Maintenance Procedures (Maintenance Procedures Which May Contribute to a Severe Service Application)

- Inadequate maintenance of fuel storage tanks from causes such as excessive water, sediment, and microorganism growth.
- Extending maintenance intervals beyond the recommended intervals
- Using fluids which are not recommended in Special Publication, SEBU6250, "Caterpillar Machine Fluids Recommendations"
- Extending maintenance intervals for changing the engine oil and engine coolant without S·O·S validation

Maintenance Section
Severe Service Application

- Extending maintenance intervals for changing air filters, oil filters, and fuel filters
- Failure to use a water separator
- Using filters which are not recommended by Special Publication, PEWJ0074, "2008 Cat Filter and Fluid Application Guide"
- Storing the engine for more than 3 months but less than 1 yr (For information about engine storage, refer to Special Publication, SEHS9031, "Storage Procedure for Caterpillar Products")

i07817520

Maintenance Interval Schedule

SMCS Code: 7000

Ensure that all safety information, warnings, and instructions are read and understood before any operation or any maintenance procedures are performed.

The user is responsible for the performance of maintenance. All adjustments, the use of proper lubricants, fluids, filters, and the replacement of components due to normal wear and aging are included. Failure to adhere to proper maintenance intervals and procedures may result in diminished performance of the product and/or accelerated wear of components.

Use mileage, fuel consumption, service hours, or calendar time, WHICH EVER OCCURS FIRST, in order to determine the maintenance intervals. Products that operate in severe operating conditions may require more frequent maintenance. Refer to the maintenance procedure for any other exceptions that may change the maintenance intervals.

Note: The aftertreatment system can be expected to function properly for the useful life of the engine (emissions durability period), as defined by regulation. All prescribed maintenance requirements must be followed.

Note: Before each consecutive interval is performed, all maintenance from the previous interval must be performed.

Note: If Cat HYDO Advanced hydraulic oils are used, the hydraulic oil change interval is extended to 6000 hours. S·O·S services after 3000 hours is strongly recommended. Consult your Cat dealer for details.

When Required

“ Air Conditioner/Cab Heater Filter (Recirculation) - Inspect/Replace”	242
“ Battery - Recycle”	242
“ Battery or Battery Cable - Inspect/Replace”	242
“ Bucket Linkage - Inspect/Adjust”	244
“ Bucket Tips - Inspect/Replace”	249
“ Bucket Tips - Inspect/Replace”	246
“ Bucket Tips - Inspect/Replace”	252
“ Cab Air Filter (Fresh Air) - Clean/Replace”	255
“ Cab Door Latch - Inspect/Adjust/Replace”	256
“ Camera - Clean”	257

“ Circuit Breakers - Reset”	258
“ Cooling System Coolant Level - Check”	262
“ DEF Filler Screen - Clean”	264
“ Diesel Exhaust Fluid - Fill”	269
“ Engine Air Filter Primary Element - Clean/Replace”	270
“ Engine Air Filter Secondary Element - Replace”	273
“ Engine Oil Level - Check”	273
“ Ether Starting Aid Cylinder - Replace”	277
“ Fuel System - Prime”	281
“ Fuel System Water Separator - Drain”	284
“ Fuses - Replace”	286
“ High Intensity Discharge Lamp (HID) - Replace”	288
“ Radiator, Aftercooler and Oil Cooler Cores - Clean”	311
“ Track Adjustment - Adjust”	317
“ Window Washer Reservoir - Fill”	320
“ Window Wiper - Inspect/Replace”	321
“ Window - Check”	321
“ Windows - Clean”	321

Every 10 Service Hours or Daily

“ Boom and Stick Linkage - Lubricate”	243
“ Bucket Linkage - Lubricate”	245
“ Fuel Tank Water and Sediment - Drain”	285
“ Hydraulic System Oil Level - Check”	306
“ Indicators and Gauges - Test”	308
“ Seat Belt - Inspect”	312
“ Track Adjustment - Inspect”	319
“ Travel Alarm - Test”	319

“ Undercarriage - Check” 320

Every 100 Service Hours of Continuous Hammer Use

“Oil Filter (Hydraulic Hammer) - Replace” 309

Initial 250 Service Hours

“ Final Drive Oil - Change” 278

“ Hydraulic System Oil Filter (Case Drain) - Replace” 297

“ Hydraulic System Oil Filter (Pilot) - Replace” . . . 299

“ Hydraulic System Oil Filter (Return) - Replace” 301

“ Swing Drive Oil - Change” 313

Every 250 Service Hours

“ Engine Oil Sample - Obtain” 274

“ Swing Bearing - Lubricate” 313

“ Final Drive Oil Sample - Obtain” 280

Every 250 Service Hours or Monthly

“ Condenser (Refrigerant) - Clean” 259

“ Final Drive Oil Level - Check” 279

“ Swing Drive Oil Level - Check” 315

Every 250 Service Hours of Partial Hammer Use (50% of Service Hours)

“Oil Filter (Hydraulic Hammer) - Replace” 309

Every 250 Service Hours of Continuous Hammer Use

“ Hydraulic System Oil Filter (Case Drain) - Replace” 297

“ Hydraulic System Oil Filter (Pilot) - Replace” . . . 299

Initial 500 Hours (for New Systems, Refilled Systems, and Converted Systems)

“Cooling System Coolant Sample (Level 2) - Obtain” 264

Every 500 Service Hours

“ Hydraulic System Oil Sample - Obtain” 308

“ Swing Drive Oil Sample - Obtain” 316

Every 500 Service Hours or 3 Months

“ Belt - Inspect/Adjust/Replace” 243

“ Boom and Stick Linkage - Lubricate” 243

“Cooling System Coolant Sample (Level 1) - Obtain” 263

“ Engine Oil and Filter - Change” 274

“ Fuel System Primary Filter (Water Separator) Element - Replace” 282

“ Fuel System Secondary Filter - Replace” 283

“ Fuel Tank Strainer - Clean” 284

Every 500 Service Hours of Partial Hammer Use (50% of Service Hours)

“ Hydraulic System Oil Filter (Case Drain) - Replace” 297

“ Hydraulic System Oil Filter (Pilot) - Replace” . . . 299

Every 600 Service Hours of Continuous Hammer Use

“ Hydraulic System Oil - Change” 288

“ Hydraulic System Oil - Change” 293

“ Hydraulic System Oil Filter (Return) - Replace” 301

Every 1000 Service Hours or 6 Months

“ Battery - Clean” 242

“ Battery Hold-Down - Tighten” 242

“ Fuel Tank Cap Filter - Replace”	284
“ Hydraulic System Oil Filter (Case Drain) - Replace”	297
“ Hydraulic System Oil Filter (Pilot) - Replace”	299
“ Rollover Protective Structure (ROPS) - Inspect”	312
“ Swing Drive Oil - Change”	313

Every 1000 Service Hours of Partial Hammer Use (50% of Service Hours)

“ Hydraulic System Oil - Change”	288
“ Hydraulic System Oil - Change”	293
“ Hydraulic System Oil Filter (Return) - Replace”	301

Every 1500 Service Hours or 9 Months

“ Fumes Disposal Filter Element - Replace”	285
--	-----

Every 2000 Service Hours or 1 Year

“ Final Drive Oil - Change”	278
“ Hydraulic System Oil Filter (Return) - Replace”	301
“ Receiver Dryer (Refrigerant) - Replace”	311
“ Swing Gear - Lubricate”	316

Every Year

“Cooling System Coolant Sample (Level 2) - Obtain”	264
--	-----

Every 3000 Service Hours or 18 Months

“ Fuel Lift Pump Strainer - Replace”	280
--	-----

Every 3 Years After Date of Installation or Every 5 Years After Date of Manufacture

“ Seat Belt - Replace”	312
----------------------------------	-----

Every 5000 Service Hours

“ Diesel Exhaust Fluid Filter - Replace”	267
--	-----

“ Diesel Exhaust Fluid Injector - Replace”	268
--	-----

Every 6000 Service Hours or 3 Years

“ Cooling System Coolant Extender (ELC) - Add”	261
“ Hydraulic System Oil - Change”	288
“ Hydraulic System Oil - Change”	293

Every 10 000 Service Hours

“ DEF Manifold Filters - Replace”	265
---	-----

Every 12 000 Service Hours or 6 Years

“ Cooling System Coolant (ELC) - Change”	259
--	-----

i04004709

i00934864

Air Conditioner/Cab Heater Filter (Recirculation) - Inspect/Replace

SMCS Code: 1054-040-A/C; 1054-510-A/C

NOTICE

An air recirculation filter element plugged with dust will result in decreased performance and service life to the air conditioner or cab heater.

To prevent decreased performance, clean the filter element, as required.

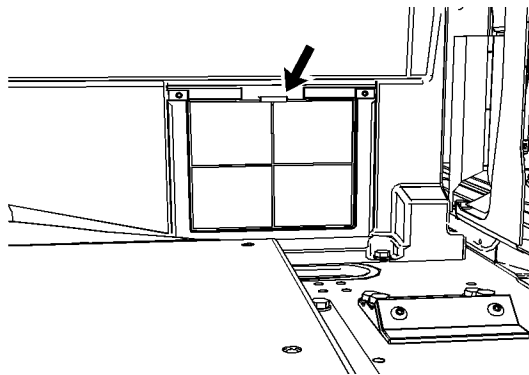

Illustration 353

g02017613

The air conditioner filter is located on the lower left side of the cab behind the seat.

1. Slide the operator seat forward.
2. Slide the filter element upward.
3. Tap the air filter in order to remove the dirt. Do not use compressed air to clean the filter.
4. After you clean the filter element, inspect the filter element. If the filter element is damaged or badly contaminated, use a new filter element. Make sure that the filter element is dry.
5. Install the filter element.

NOTICE

Failure to reinstall the filter element for the air conditioning system will contaminate and damage the system components.

Battery - Clean

SMCS Code: 1401-070

Clean the battery surface with a clean cloth. Keep the terminals clean and keep the terminals coated with petroleum jelly. Install the post cover after you coat the terminal post with petroleum jelly.

i07746330

Battery - Recycle

SMCS Code: 1401-561

Always recycle a battery. Never discard a battery.

Always return used batteries to one of the following locations:

- A battery supplier
- An authorized battery collection facility
- Recycling facility

i00934872

Battery Hold-Down - Tighten

SMCS Code: 7257

Tighten the hold-downs for the battery in order to prevent the batteries from moving during machine operation.

i04064489

Battery or Battery Cable - Inspect/Replace

SMCS Code: 1401; 1401-561; 1401-040; 1401-510; 1402-510; 1402-040

WARNING

Personal injury can result from battery fumes or explosion.

Batteries give off flammable fumes that can explode. Electrolyte is an acid and can cause personal injury if it contacts the skin or eyes.

Prevent sparks near the batteries. Sparks could cause vapors to explode. Do not allow jumper cable ends to contact each other or the engine. Improper jumper cable connections can cause an explosion.

Always wear protective glasses when working with batteries.

1. Turn all of the switches to the OFF position. Turn the engine start switch key to the OFF position.
2. Turn the battery disconnect switch to the OFF position. Remove the key.
3. Disconnect the negative battery cable at the battery.
4. Disconnect the positive battery cable at the battery.
5. Disconnect the battery cables at the battery disconnect switch. The battery disconnect switch is connected to the machine frame.
6. Make necessary repairs or replace the battery.
7. Connect the battery cable at the battery disconnect switch.
8. Connect the positive battery cable of the battery.
9. Connect the negative battery cable of the battery.
10. Install the key and turn the battery disconnect switch to the ON position.

i07197963

Belt - Inspect/Adjust/Replace

SMCS Code: 1357-040; 1357-510; 1357-025; 1397-025; 1397-040; 1397-510

Note: This engine is equipped with a belt tightener that automatically adjusts the belt to the correct tension.

1. Unlatch the engine hood and raise the engine hood.

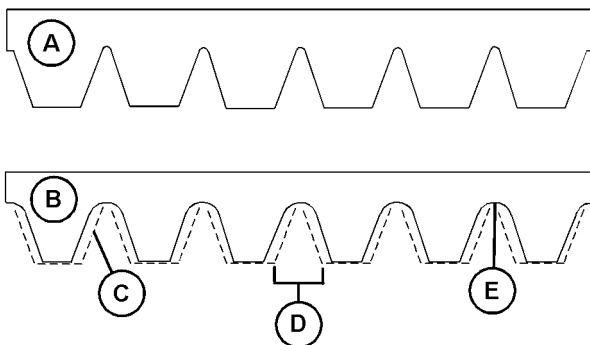

Illustration 354

g06114636

- (A) New belt
(B) Worn belt

2. Inspect the condition of the serpentine belt. Over time the belt ribs will lose material (C). The space between the ribs will increase (D). The loss of material will cause the pulley sheave to contact the belt valley. This will lead to belt slippage and accelerated wear (E). Replace the belt if the belt is worn or frayed.
3. If the belt requires replacement, perform Step 3a through Step 3f.
 - a. Remove the upper fan guard.

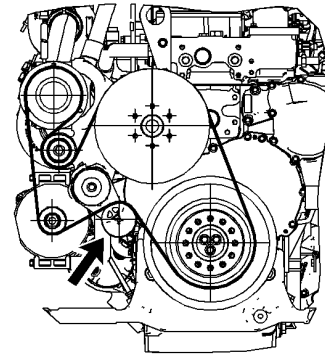

Illustration 355

g02153037

- b. Rotate the belt tensioner clockwise in order to remove the belt.
- c. Remove the belt.
- d. Install a new belt.
- e. Rotate the belt tensioner clockwise in order to install the belt.
- f. Install the upper fan guard.
- g. Lower the engine hood and latch the engine hood.

i02290574

Boom and Stick Linkage - Lubricate

SMCS Code: 6501-086; 6502-086

Note: Caterpillar recommends the use of 5P-0960 Molybdenum Grease for lubricating the boom, stick and bucket control linkage. Refer to Special Publication, SEBU6250, "Caterpillar Machine Fluids Recommendations" for more information on molybdenum grease.

Apply lubricant through all fittings after operation under water.

Wipe all fittings before you apply lubricant.

Maintenance Section
Bucket Linkage - Inspect/Adjust

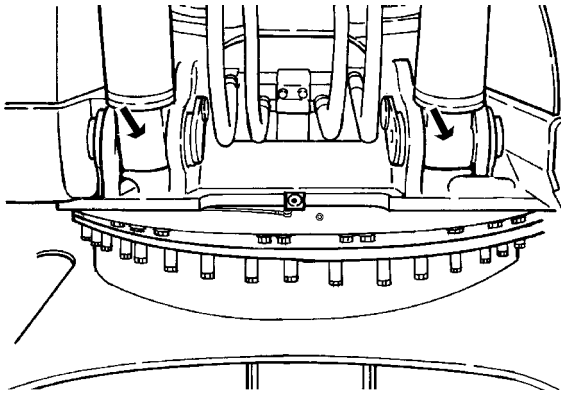

Illustration 356 g01146788

The fitting is located on the back of the base of each boom cylinder.

1. Apply lubricant through the fitting at the base of each boom cylinder.

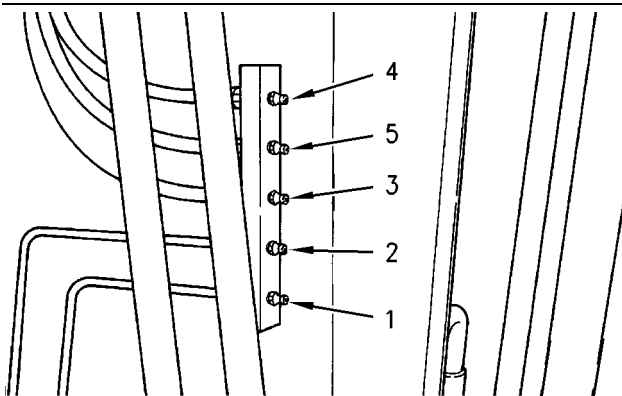

Illustration 357 g00685798

2. The fittings are at the base of the boom. The fittings can be serviced from the platform on top of the storage box. To lubricate the lower boom bearings, apply lubricant through fittings (1) and (2).
3. Apply lubricant through fittings (3) and (4) for the boom cylinder rod.
4. Apply lubricant through fitting (5) for the stick cylinder head.

Note: To ensure proper lubrication of the lower boom bearings and of the boom cylinder rod end bearings, lubricant should be applied through fittings (1), (2), (3), and (4). Apply lubricant first when the boom is raised and any attachment is suspended. Then apply lubricant when the boom is lowered and the attachment is rested on the ground with a slight downward pressure.

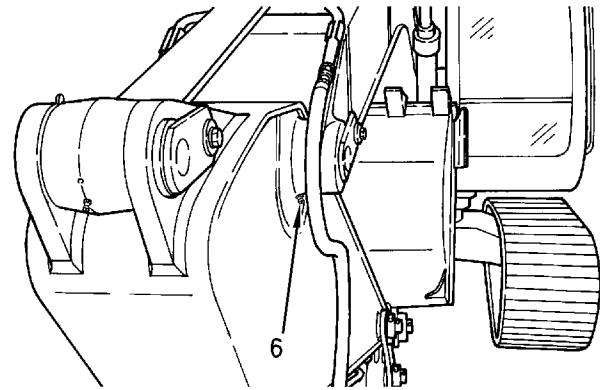

Illustration 358 g00685799

5. Apply lubricant through fitting (6). Fitting (6) is at the connection point of the boom and of the stick.

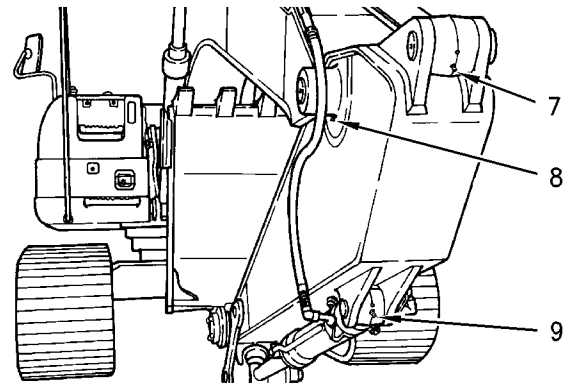

Illustration 359 g00685800

6. Apply lubricant through fitting (7) on the stick cylinder rod, fitting (8) at the connection point of the boom and of the stick, and fitting (9) at the bucket cylinder head end.

i03902571

Bucket Linkage - Inspect/Adjust

SMCS Code: 6513-025; 6513-040

WARNING

Unexpected machine movement can cause injury or death.

To avoid possible machine movement, move the hydraulic lockout control to the LOCKED position and attach a Special Instruction, SEHS7332, "Do Not Operate" or similar warning tag to the hydraulic lockout control.

NOTICE

Improperly adjusted bucket clearance could cause galling on the contact surfaces of the bucket and stick, resulting in excessive noise and/or damaged O-ring seals.

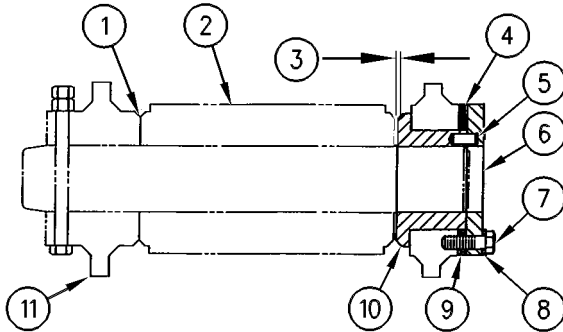

Illustration 360

g00101687

(1) No gap. (2) Stick boss. (3) Bucket clearance. (4) Shims. (5) Pin. (6) Plate. (7) Bolts. (8) Washers. (9) Location. (10) Flange. (11) Bucket boss.

The clearance of the bucket control linkage on this machine can be adjusted by shimming. If the gap between the bucket and the stick becomes excessive, adjust bucket clearance (3) to 0.5 to 1 mm (0.02 to 0.04 inch).

Two shims of different thickness are used at location (9). The thicknesses of the shims are 0.5 mm (0.02 inch) and 1.0 mm (0.04 inch).

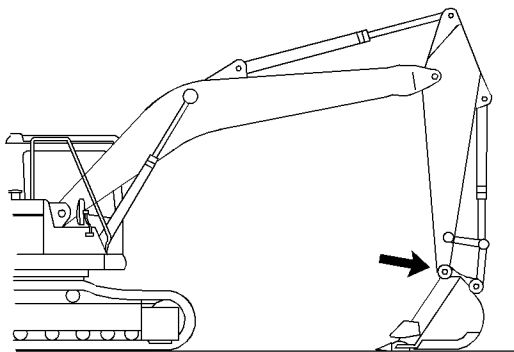

Illustration 361

g02109636

Area for linkage adjustment

1. Position the machine on a level surface and lower the bucket to the ground.
2. Slowly operate the swing control lever until stick boss (2) and the bucket boss (11) are in full face contact at no gap (1). This will help to determine the total clearance of the connection point of the stick and of the bucket.

3. Move the hydraulic lockout control to the LOCKED position. Stop the engine.

4. Measure bucket clearance (3), which is the existing total clearance.

5. Determine the number of shims that need to be removed from shims (4) by using the following calculation:

Subtract 0.5 mm (0.02 inch) or 1.0 mm (0.04 inch) from bucket clearance (3).

6. Remove the appropriate number of shims at location (9) in order to meet the above thickness. Make sure that you use a minimum of three 0.5 mm (0.02 inch) shims. To remove the shims, remove bolts (7), washers (8), and plate (6).

7. After the correct number of shims has been removed and pin (5) is aligned with the pin hole, install plate (6), washers (8), and bolts (7). Tighten bolts (7) to a torque of 240 ± 40 N·m (175 ± 30 lb ft).

8. After installation, make sure that bucket clearance (3) is still correct.

i01987344

Bucket Linkage - Lubricate**SMCS Code:** 6513-086

Wipe all fittings before you apply lubricant.

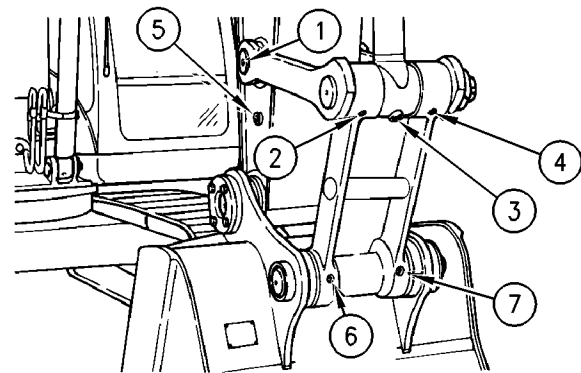

Illustration 362

g00750605

Note: Completely fill all cavities of the bucket control linkage with grease when you initially install a bucket.

1. Apply lubricant through fittings for the linkages (1), (2), (3), and (4).
2. Apply lubricant through fittings for the bucket (5), (6), and (7).

Note: Service the above fittings after you operate the bucket under water.

Installation of the Bucket

Use the procedure that follows when a bucket is changed. Use the procedure that follows when a new pin is installed. Use the procedure that follows when new bearings are installed.

Note: Fill the cavity of the stick nose with grease before you install the pin.

1. Insert the pin into the stick nose.
2. Secure the bucket to the stick.

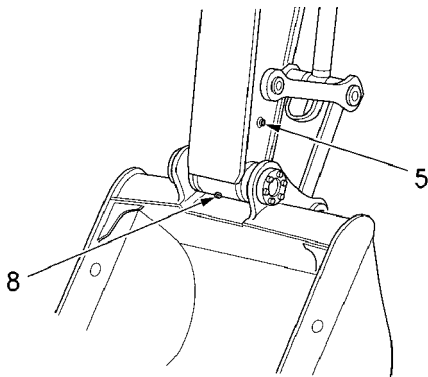

Illustration 363

g00840339

- (5) Fitting
(8) Plug

3. Remove plug (8).
4. Apply grease through fitting (5).
5. Fill until grease flows out of plug (8).
6. Install plug (8) and tighten plug (8).
7. Continue to fill with grease until the grease is visible on both sides of stick nose.
8. Apply lubricant through fittings for the bucket (6), and (7). Continue to fill with grease until the grease is visible on both sides of power link.

i03450548

Bucket Tips - Inspect/Replace (Drive-through System)

SMCS Code: 6805-510; 6805-040

WARNING

Personal injury or death can result from bucket falling.

Block the bucket before changing bucket tips or side cutters.

Bucket Tips

Note: In order to maximize the life of the bucket tip and the penetration of the bucket tip, the bucket tip can be rotated.



Illustration 364

g01055179

Acceptable wear



Illustration 365

g01055196

Replace this bucket tip.

Check the bucket tips for wear. If the bucket tip has a hole, replace the bucket tip.

Removal Procedure

WARNING

Retainer pin, when struck with force, can fly out and cause injury to nearby people.

Make sure the area is clear of people when driving retainer pins.

To avoid injury to your eyes, wear protective glasses when striking a retainer pin.

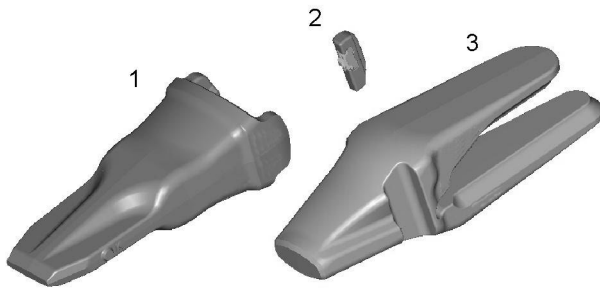

Illustration 366

g01053737

- (1) Bucket tip
- (2) Retainer
- (3) Adapter

Note: Retainers are often damaged during the removal process. Caterpillar recommends the installation of a new retainer when bucket tips are rotated or replaced.

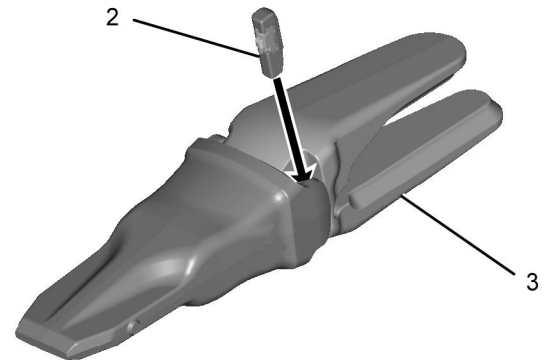

Illustration 368

g01498093

Proper location for installing the retainer

3. The retainer can be installed from the top of the bucket tip or from the bottom of the bucket tip. Use a hammer and a 1 inch X 1 inch X 8 inch steel bar stock in order to drive retainer (2) into adapter (3).

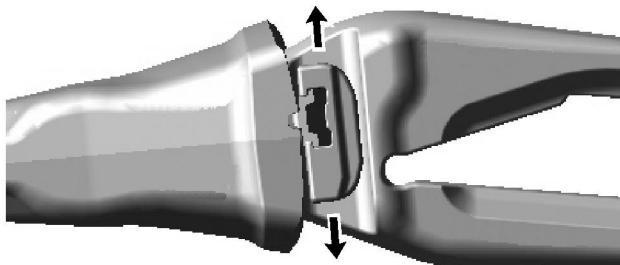

Illustration 367

g01054386

Internal view

1. Use a hammer and a punch in order to drive out the retainer. The retainer can be removed from the top of the bucket tip or from the bottom of the bucket tip.
2. Remove the bucket tip from the adapter with a slight counterclockwise rotation.

Installation Procedure

1. Clean the adapter, if necessary.
2. Install the new bucket tip or the rotated bucket tip onto the adapter with a slight clockwise rotation.

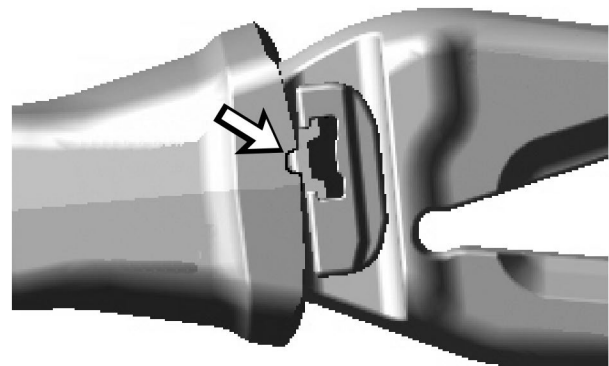

Illustration 369

g01492733

Internal View

The latch of the retainer is properly seated in the recess of the bucket tip.

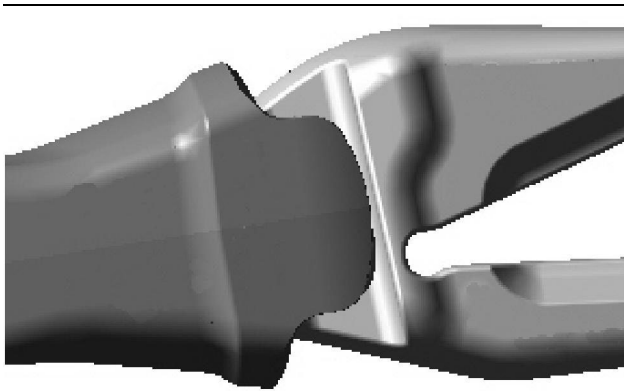

Illustration 370

g01054753

A properly installed retainer does not extend beyond the ear of the bucket tip.

- The retainer is properly seated if the retainer can be moved slightly by the technician's hand. If the retainer cannot be moved, adjust the retainer, as needed. The ends of the retainer should not extend beyond the ear of the bucket tip.

Side Cutters (If Equipped)

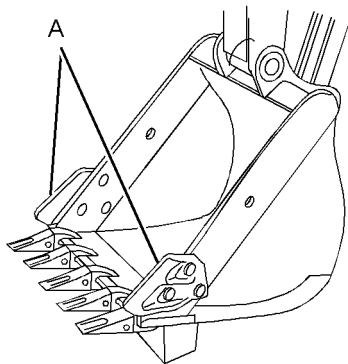

Illustration 371

g01092808

Bucket with side cutters

(A) Side cutters

- Remove the mounting bolts and the side cutters.
- Clean the mounting surface of the side plate on the bucket and of the side cutter. Remove any burrs or protrusions on the mating surfaces.

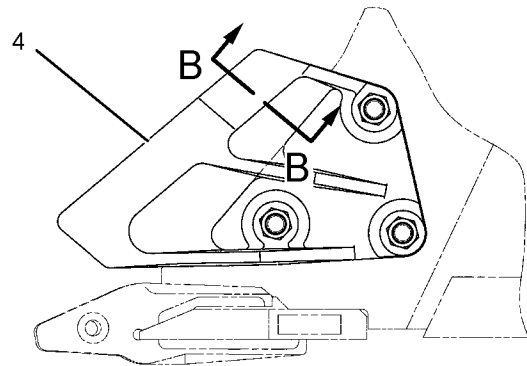

Illustration 372

g01389435

(4) Side cutter

Note: Some side cutters may be rotated for additional wear.

- Install the side cutter.

Note: Certain bolts may require thread compound.

- Hand tighten the bolts.

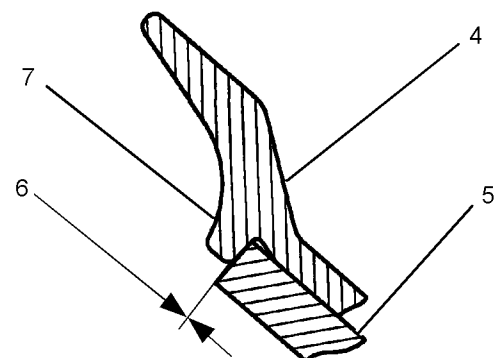

Illustration 373

g01389433

Section B-B From Illustration 372

(4) Side cutter
(5) Side plate on a bucket
(6) 0.0 mm (0.0 inch)
(7) Shear ledge on a side cutter

- Make sure that there is not a gap between the side plate on the bucket and the shear ledge on the side cutter.
- Torque the mounting bolts to the correct specification.

Side Protectors (If Equipped)

Inspect the wear of the side protector. When too much wear is present, replace the protector.

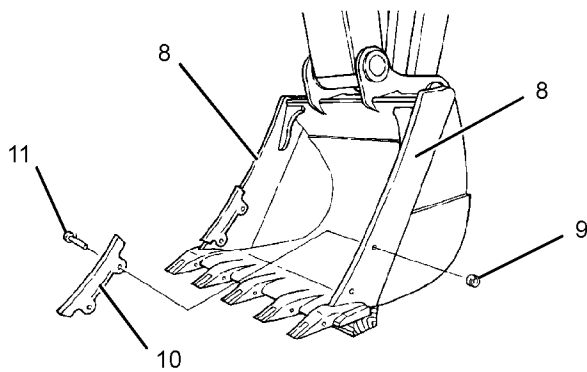

Illustration 374

g01389452

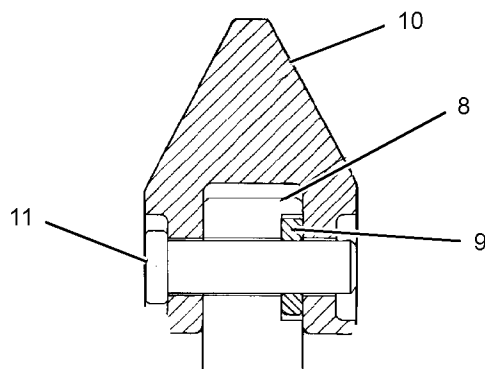

Illustration 375

g01389453

(8) Side plate
(9) Retainer
(10) Side protector
(11) Pin

1. Hit pin (11) from the retainer side of the bucket in order to remove side protector (10) from side plate (8).
2. Clean side protector (10), pin (11), retainer (9) and side plate (8) before installation.

Note: Lateral clearance between the side plate and the side protector should not exceed 1 mm (0.04 inch). Shims may be required in order to decrease the lateral clearance which will decrease movement. Install the shims between the side plate and the side protector on the opposite side of the retainer.

3. Put retainer (9) in side plate (8).
4. Align two pin holes of the new protector and the side plate. Hit the pin from the side of the bucket without the retainer.

Note: If the pin and/or the retainer are worn, replace the pin and/or the retainer.

i03574841

Bucket Tips - Inspect/Replace

SMCS Code: 6805-510; 6805-040

WARNING

Personal injury or death can result from the bucket falling.

Block the bucket before changing bucket tips.

Note: In order to maximize the life of the bucket tip and the penetration of the bucket tip, the bucket tip can be rotated.

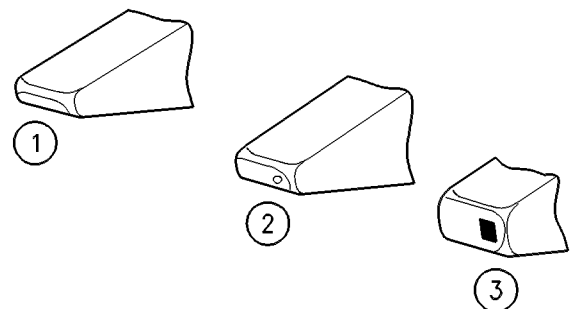

Illustration 376

g00101352

(1) Usable
(2) Replace
(3) Overworn

Check the bucket tips for wear. If the bucket tip has a hole, replace the bucket tip.

Removal

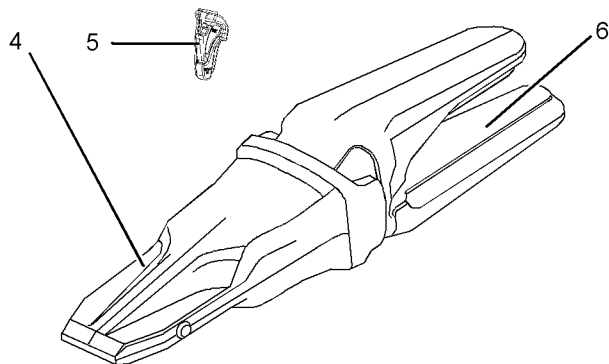

Illustration 377

g01389463

Note: Retainers are often damaged during the removal process. Caterpillar recommends the installation of a new retainer when bucket tips are rotated or replaced.

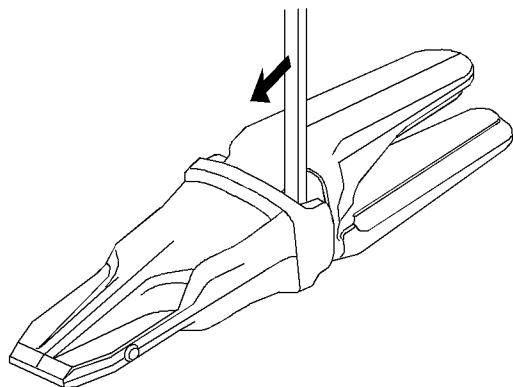

Illustration 378

g01175361

1. Use a pry bar in order to disengage retainer (5).
2. Use the pry bar in order to remove retainer (5) from bucket tip (4).
3. Remove bucket tip (4) from adapter (6) with a slight counterclockwise rotation.
4. Clean adapter (6).

Installation

1. Clean the adapter and the area around the latch, if necessary.
2. Install the new bucket tip onto the adapter with a slight clockwise rotation.

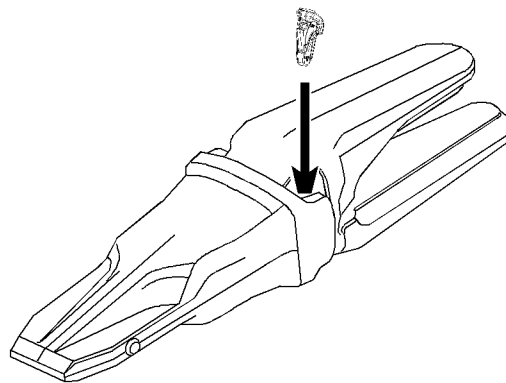

Illustration 379

g01124736

3. Install the retainer. Make sure that the retainer's latch catches under the tip pocket.
4. Make sure that the latch is properly seated by trying to remove the bucket tip.

Side Cutters (If Equipped)

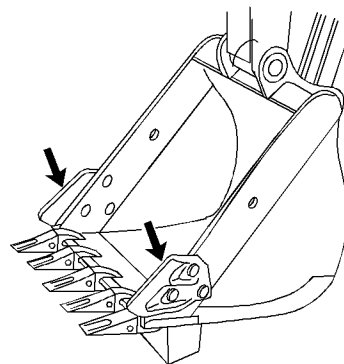

Illustration 380

g01389740

Bucket with side cutters
 Side cutters

1. Remove the mounting bolts and the side cutters.
2. Clean the mounting surface of the side plate on the bucket and of the side cutter. Remove any burrs or protrusions on the mating surfaces.

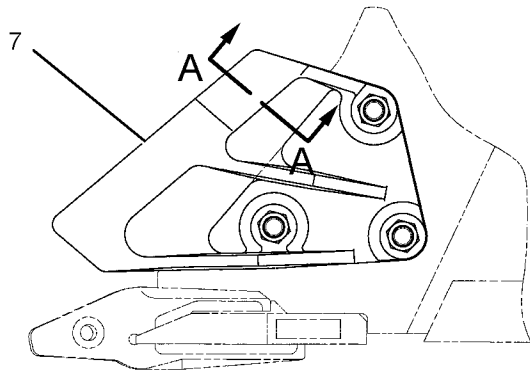

Illustration 381 g01389456
(7) Side cutter

Note: Some side cutters may be rotated for additional wear.

3. Install the side cutter.

Note: Certain bolts may require thread compound.

4. Hand tighten the bolts.

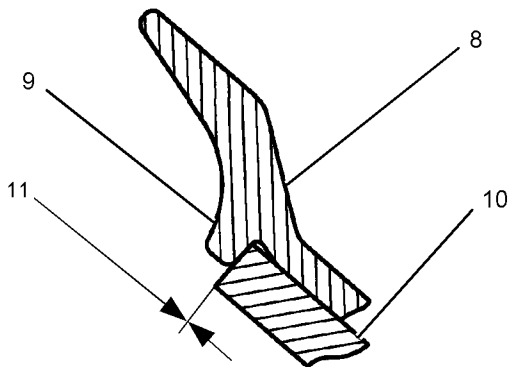

Illustration 382 g01389457
Section A-A From Illustration 381
(8) Side cutter
(9) Shear ledge on a side cutter
(10) Side plate on a bucket
(11) 0.0 mm (0.0 inch)

5. Make sure that there is not a gap between the side plate on the bucket and the shear ledge on the side cutter.

6. Torque the mounting bolts to the correct specification.

Side Protectors (If Equipped)

Inspect the wear of the side protector. When too much wear is present, replace the protector.

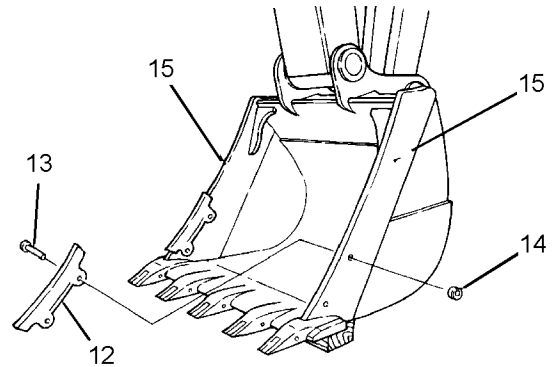

Illustration 383 g01389458

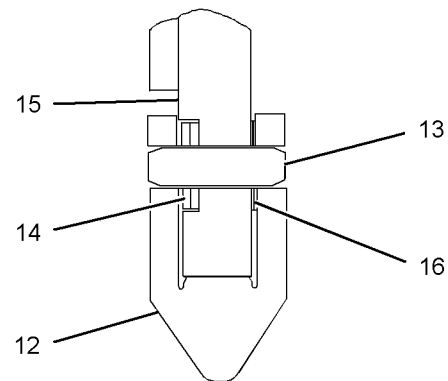

Illustration 384 g01903698

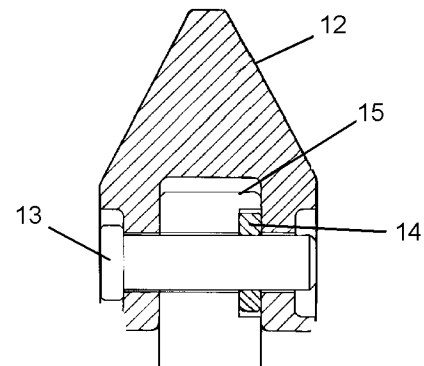

Illustration 385 g01389459
(12) Side protector
(13) Pin
(14) Retainer
(15) Side plate
(16) Shim

1. Hit pin (13) from the side of the bucket without the retainer in order to remove side protector (12) from side plate (15).

Maintenance Section
Bucket Tips - Inspect/Replace

- Clean side protector (12), pin (13), retainer (14) and side plate (15) before installation.

Note: Lateral clearance between the side plate and the side protector should not exceed 1 mm (0.04 inch). Shims (16) may be required in order to decrease the lateral clearance which will decrease movement. Install the shims(16) between the side plate and the side protector on the opposite side of the retainer.

- Put retainer (14) in side plate (15).
- Align two pin holes of the new protector and the side plate. Hit the pin from the retainer side of the bucket.

Note: If the pin and/or the retainer are worn, replace the pin and/or the retainer.

i03574842

Bucket Tips - Inspect/Replace

SMCS Code: 6805-510; 6805-040

WARNING

Block the bucket before changing the bucket teeth.

To prevent possible injury to the eyes, wear a protective face shield when striking the pin.

The pin, when struck, can fly out and cause injury to nearby personnel.

Bucket Tips

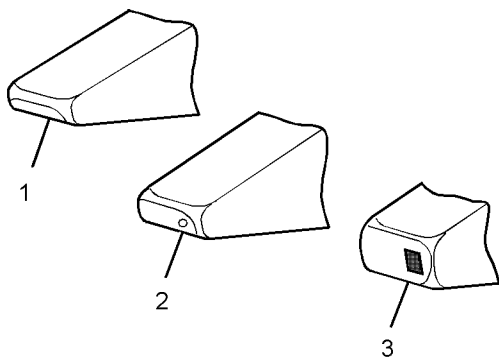

Illustration 386

g01577934

- Usable tip
- Replaceable bucket tip
- Overworn tip

Check the bucket tips for wear. If the bucket tip has a hole, replace the bucket tip.

- Remove the pin from the bucket tip. The pin can be removed by one of the following methods.

- Use a hammer and a punch from the retainer side of the bucket to drive out the pin.
- Use a Pin-Master. Follow Step 1a through Step 1c for the procedure.

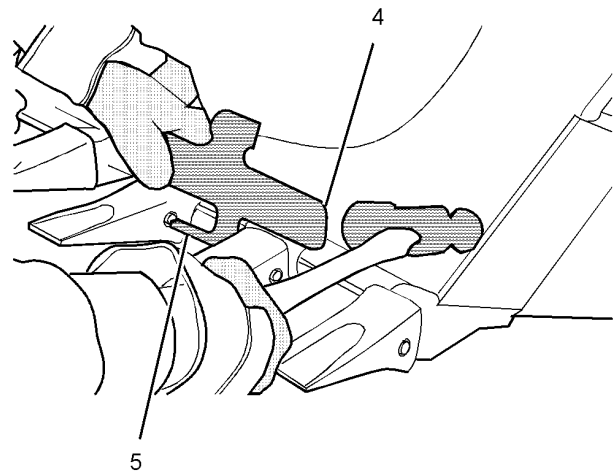

Illustration 387

g01577993

- Back of Pin-Master
- Extractor

- Place the Pin-Master on the bucket tip.
- Align extractor (5) with the pin.
- Strike the Pin-Master at the back of the tool (4) and remove the pin.

Note: Discard the old pin and the retainer assembly. When you change tips, use a new pin and a new retainer assembly. Refer to the appropriate parts manual for your machine.

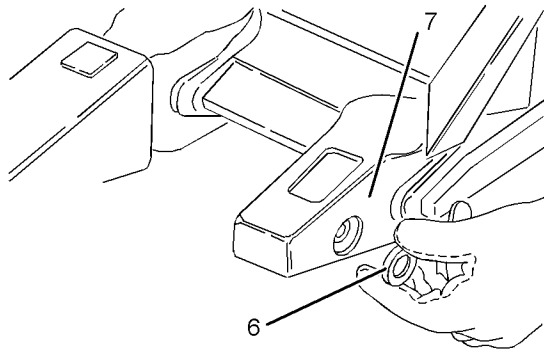

Illustration 388

g01577913

(6) Retainer assembly
(7) Adapter

2. Clean the adapter and the pin.

3. Fit retainer assembly (6) into the counterbore that is in the side of adapter (7). Make sure that the face of the retainer assembly with the marking "OUTSIDE" is visible.

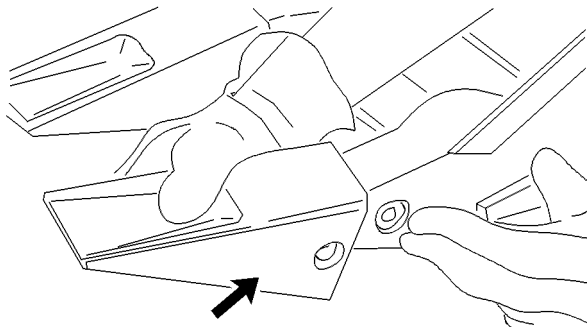

Illustration 389

g00101359

4. Install the new bucket tip onto the adapter.

Note: The bucket tips can be rotated by 180 degrees in order to allow the tip to wear evenly. You may also move the tips from the outside teeth to the inside teeth. Check the tips often. If wear is present on the tips, rotate the tips. The outside teeth generate the most wear.

5. Drive the pin through the bucket tip. The pin can be installed by using one of the following methods:

- From the same side of the retainer, drive the pin through the bucket tip, the retainer assembly, and the adapter.
- Use a Pin-Master. Follow Step 5a through Step 5e for the procedure.

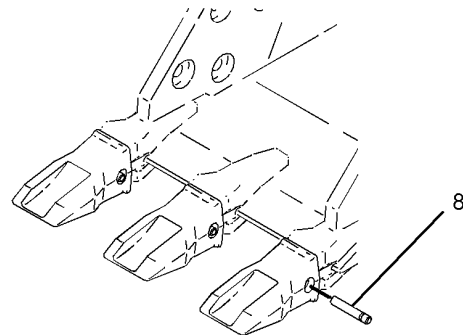

Illustration 390

g01578233

(8) Pin

a. Insert pin (8) through the bucket tip.

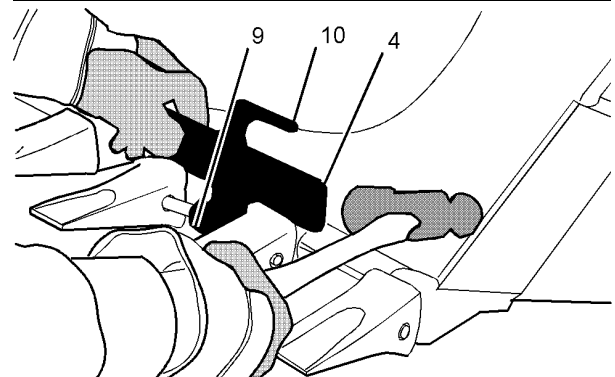

Illustration 391

g01578342

b. Place the Pin-Master over the bucket tips so that the pin will fit into the counterbore of the pin holder (9).

c. Strike the Pin-Master with a hammer at the back of the tool (4) in order to insert the pin.

d. Slide pin holder (9) away from the pin and rotate the tool slightly in order to align pin setter (10) with the pin.

Maintenance Section
Bucket Tips - Inspect/Replace

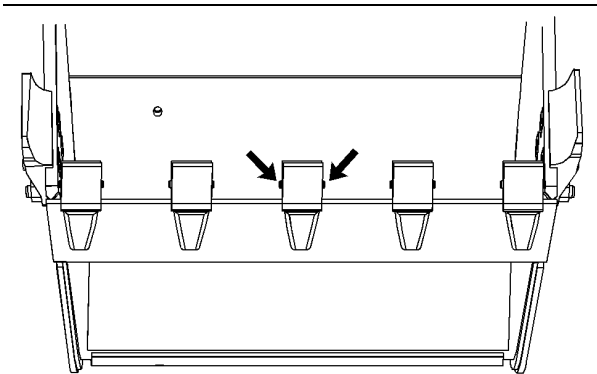

Illustration 392 g01209159

Final assembly of pin into bucket tip

- e. Strike the end of the tool until the pin is fully inserted.

Side Cutters

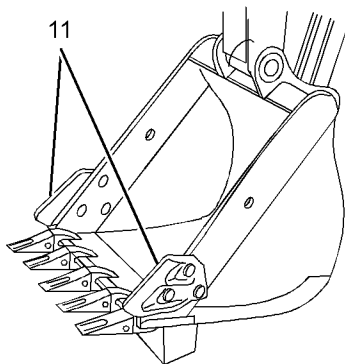

Illustration 393 g01579693

Bucket With Side Cutters

1. Remove the mounting bolts and the side cutters (11).
2. Clean the mounting surface of the side plate on the bucket and of the side cutter. Remove any burrs or protrusions on the mating surfaces.

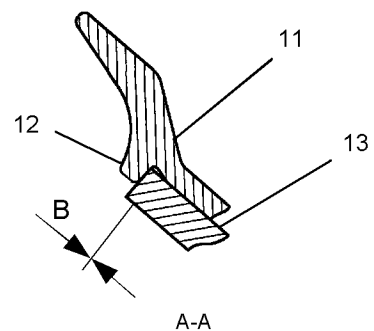
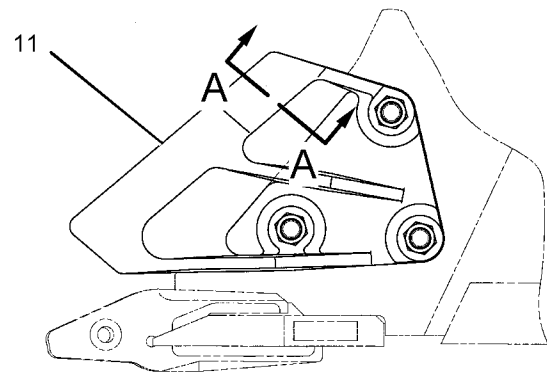

Illustration 394 g01579713

- (12) Shear ledge on a side cutter
(13) Side plate on a bucket
(B) 0.0 mm (0.0 inch)

Note: Some side cutters may be rotated for additional wear.

3. Install the side cutter.

Note: Certain bolts may require thread compound.

4. Hand tighten the bolts.
5. Make sure that there is not a gap between the side plate on the bucket and the shear ledge on the side cutter.
6. Torque the mounting bolts to the correct specification.

Side Protectors (If Equipped)

Inspect the wear of the side protector. When too much wear is present, replace the protector.

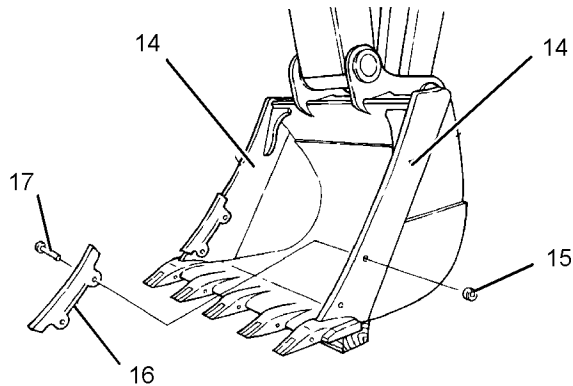

Illustration 395

g01592996

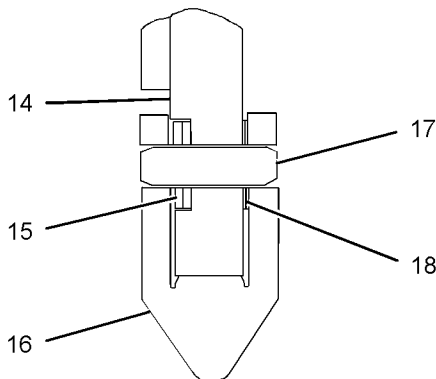

Illustration 396

g01903678

- (14) Side plate
- (15) Retainer
- (16) Side protector
- (17) Pin
- (18) Shim

1. Hit pin (17) from the side of the bucket without the retainer in order to remove side protector (16) from side plate (14).
2. Clean side protector (16), pin (17), retainer (15) and side plate (14) before installation.

Note: Lateral clearance between the side plate and the side protector should not exceed 1 mm (0.04 inch). Shims (18) may be required in order to decrease the lateral clearance which will decrease movement. Install the shims (18) between the side plate and the side protector on the opposite side of the retainer.

3. Put retainer (15) in side plate (14).

4. Align two pin holes of the new protector and the side plate. Hit the pin from the retainer side of the bucket.

Note: If the pin and/or the retainer are worn, replace the pin and/or the retainer.

i03901495

Cab Air Filter (Fresh Air) - Clean/Replace

SMCS Code: 7342-070; 7342-510

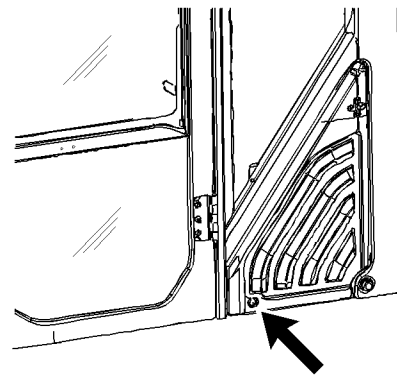

Illustration 397

g01973174

The cab air filter is located on the left side of the cab.

1. Use the ignition key in order to open the access panel.

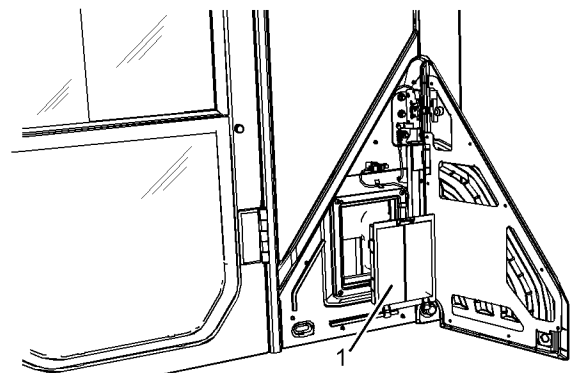

Illustration 398

g02144326

(1) Air filter

2. Remove air filter (1).
3. Clean the air filter with a maximum of 200 kPa (30 psi) pressure air.
4. After you clean the air filter, inspect the air filter. If the air filter is damaged or badly contaminated, use a new air filter.

5. Install the air filter and the filter cover.

i04281350

Cab Door Latch - Inspect/ Adjust/Replace

SMCS Code: 7308-LX

Cab Door Latch Inspect

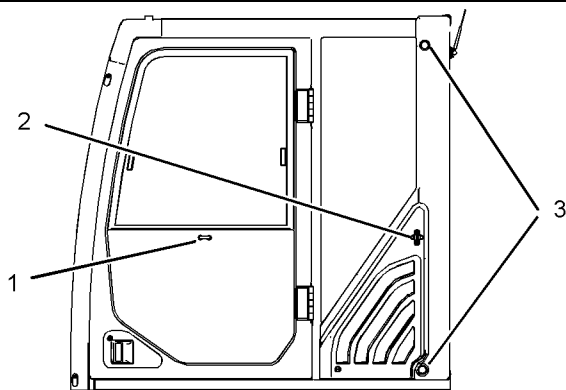

Illustration 399

g02449296

- (1) Cab Door Striker
- (2) Cab Door Latch
- (3) Cab Door Stop

1. Open the cab door and latch the door in the open position.
2. Inspect door stops (3) for proper adjustment. The cab door should contact the door stops and slightly compress the rubber stoppers.

Note: Refer to “Cab Door Stop Adjust” if the door stops require adjustment.

3. Inspect the operation of the door latch. The latch should not release the door unless you pull down on one of the door release levers located in the cab. When the door is closed, the door should release from the latch smoothly.

Note: If needed, spray an appropriate lubricant throughout the latch in order to clean and lubricate the latch mechanism

4. Inspect the cab door striker (1) and the cab door latch (2). Ensure that the striker is properly aligned with the latch.
5. Close the cab door.

Note: If the door does not latch properly or if the door does not release from the latch properly, refer to “Cab Door Latch Adjust” for the adjustment procedure.

Cab Door Stop Adjust

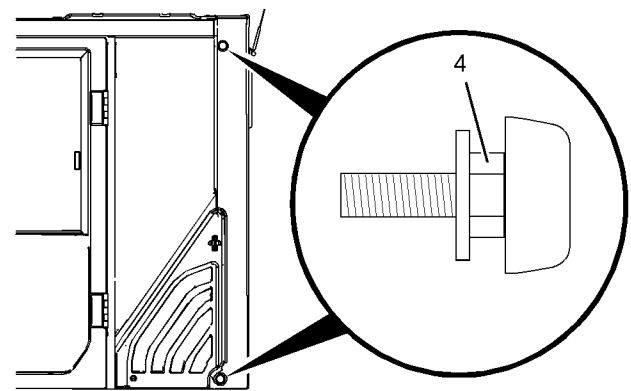

Illustration 400

g02449162

1. Completely loosen nut (4) and rotate the door stop clockwise.
2. Carefully open the cab door and latch the door in the open position.
3. Rotate the door stop counter clockwise until the door stop contacts the door.
4. Close the cab door.
5. Rotate the door stop counter clockwise an additional 1 to 1 1/4 revolutions and tighten nut (4).

Cab Door Latch Adjust

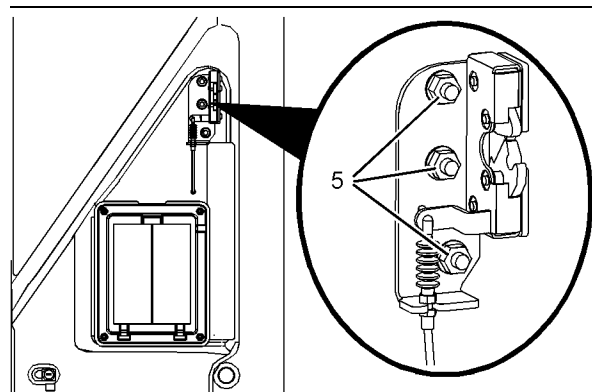

Illustration 401

g02449164

1. Use the ignition key in order to open the access panel for the cab air filter.
2. Loosen bolts (5) and align the striker on the cab door with the latch mechanism.

3. Tighten bolts (5) and close the access panel.

Cab Door Latch Replace

Cab Door Latch Removal

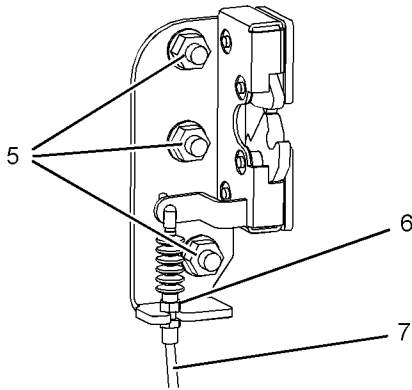

Illustration 402

g02449166

1. Use the ignition key in order to open the access panel for the cab air filter.
2. Loosen nut (6) and disconnect cable (7) from the latch assembly.
3. Remove bolts (5) in order to remove the entire latch assembly.

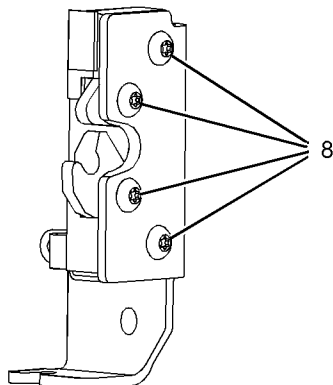

Illustration 403

g02449276

4. Remove bolts (8) and remove the latch mechanism from the assembly.

Cab Door Latch Installation

1. Perform the installation procedure in reverse order.

Note: Make sure that the striker and the latch are properly aligned. Refer to “Cab Door Latch Adjust”.

i06587366

Camera - Clean (If Equipped)

SMCS Code: 7348-070

⚠ WARNING

Failure to use an appropriate external ladder or an appropriate platform for direct access to the cameras could result in slipping and falling which could result in personal injury or death. Be sure to use an appropriate external ladder or an appropriate platform for direct access to the cameras.

The counterweight of the machine and the engine hood of the machine are not approved as maintenance platforms.

⚠ WARNING

Unexpected machine movement can cause injury or death.

In order to avoid possible machine movement, move the hydraulic lockout control to the LOCKED position and attach a Special Instruction, SEHS7332, “Do Not Operate” or similar warning tag to the hydraulic lockout control.

Note: When you access the cameras for cleaning, be sure to observe safe procedures for access. Maintain a three-point contact and/or use a body harness.

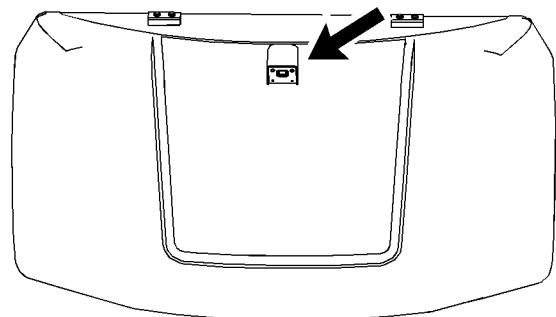

Illustration 404

g02158495

The rear view camera is located on top of the counterweight.

i05958210



Illustration 405

g06035100

The side view camera is located on top of Fuel Tank.

If necessary, use a damp cloth in order to clean the glass of the camera. The camera is sealed. The camera is not affected by a wash with high-pressure spray.

Note: Alternatively, cameras may be cleaned from ground level by using a wash with a high-pressure spray or a damp rag on a wand.

Circuit Breakers - Reset

SMCS Code: 1420-529

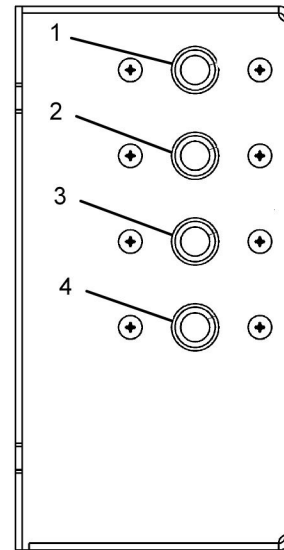

Illustration 406

g03738607

The circuit breaker is located behind the front left access door.



Diesel Exhaust Fluid Circuit (1) – This circuit breaker is designed to protect the DEF system. If the wires are shorted to the machine body, this circuit breaker would minimize the damage to the wires.



Alternator Circuit (2) – This circuit breaker is designed to protect the alternator. If the batteries are installed with reversed polarity, the circuit breaker would prevent the alternator from damaging the rectifier.



Main Circuit (3) – This circuit breaker is designed to protect the wires between the batteries and the fuses. If the wires are shorted to the machine body, this circuit breaker would minimize the damage to the wires.



Glow Plug Circuit (4) – This circuit breaker is designed to protect the glow plugs.

Circuit Breaker Reset – Push in the button in order to reset the circuit breaker. If the electrical system is working properly, the button will remain depressed. If the button does not remain depressed, check the appropriate electrical circuit. Repair the electrical circuit, if necessary.

i05354253

i06534885

Condenser (Refrigerant) - Clean

SMCS Code: 1805-070

WARNING

Personal injury can result from air pressure.

Personal injury can result without following proper procedure. When using pressure air, wear a protective face shield and protective clothing.

Maximum air pressure at the nozzle must be less than 205 kPa (30 psi) for cleaning purposes.

NOTICE

If excessively dirty, clean condenser with a brush. To prevent damage or bending of the fins, do not use a stiff brush.

Repair the fins if found defective.

1. Open the access door on the left side of the machine.

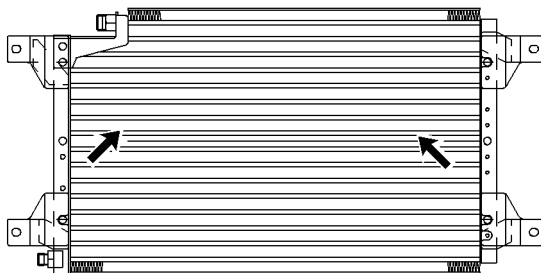

Illustration 407

g00537515

Typical example

2. Inspect the condenser for debris. Clean the condenser, if necessary.

Compressed air is preferred, but high-pressure water or steam can be used to remove dust and general debris from a core.

See Special Publication, SEBD0518, "Know Your Cooling System" for more detailed information about cleaning core fins.

3. Close the access door on the left side of the machine.

Cooling System Coolant (ELC) - Change

SMCS Code: 1350-044

WARNING

Engine hood and engine hood parts can be hot while engine is running or immediately after engine shutdown. Hot parts or hot components can cause burns or personal injury. Do not allow these parts to contact your skin, when engine is running or immediately after engine shutdown. Use protective clothing or protective equipment to protect your skin.

WARNING

Personal injury can result from hot coolant, steam and alkali.

At operating temperature, engine coolant is hot and under pressure. The radiator and all lines to heaters or the engine contain hot coolant or steam. Any contact can cause severe burns.

Remove cooling system pressure cap slowly to relieve pressure only when engine is stopped and cooling system pressure cap is cool enough to touch with your bare hand.

Do not attempt to tighten hose connections when the coolant is hot, the hose can come off causing burns.

Cooling System Coolant Additive contains alkali. Avoid contact with skin and eyes.

NOTICE

Do not change the coolant until you read and understand the cooling system information in Special Publication, SEBU6250, "Caterpillar Machine Fluids Recommendations".

Failure to do so could result in damage to the cooling system components.

NOTICE

Mixing ELC with other products will reduce the effectiveness of the coolant.

This could result in damage to cooling system components.

If Caterpillar products are not available and commercial products must be used, make sure they have passed the Caterpillar EC-1 specification for pre-mixed or concentrate coolants and Caterpillar Extender.

Maintenance Section
Cooling System Coolant (ELC) - Change

Note: This machine was filled at the factory with Cat Extended Life Coolant.

If the coolant in the machine is changed to Extended Life Coolant from another type of coolant, see Special Publication, SEBU6250, "Caterpillar Machine Fluids Recommendations".

1. Unlatch the engine hood and raise the engine hood.

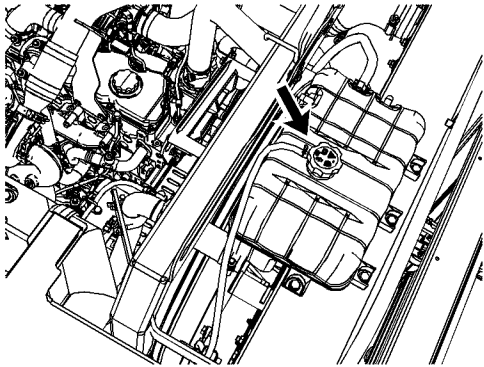

Illustration 408

g02153073

2. Slowly loosen the pressure cap that is on the coolant reservoir in order to release pressure from the cooling system.
3. Remove the pressure cap.
4. Inspect the gasket of the cooling system pressure cap. If the gasket is damaged, replace the pressure cap.

Note: Refer to Operation and Maintenance Manual, "General Hazard Information" for information that pertains to containing fluid spillage.

5. Locate the drain valve under the machine.
Remove the cover to gain access to the drain valve.

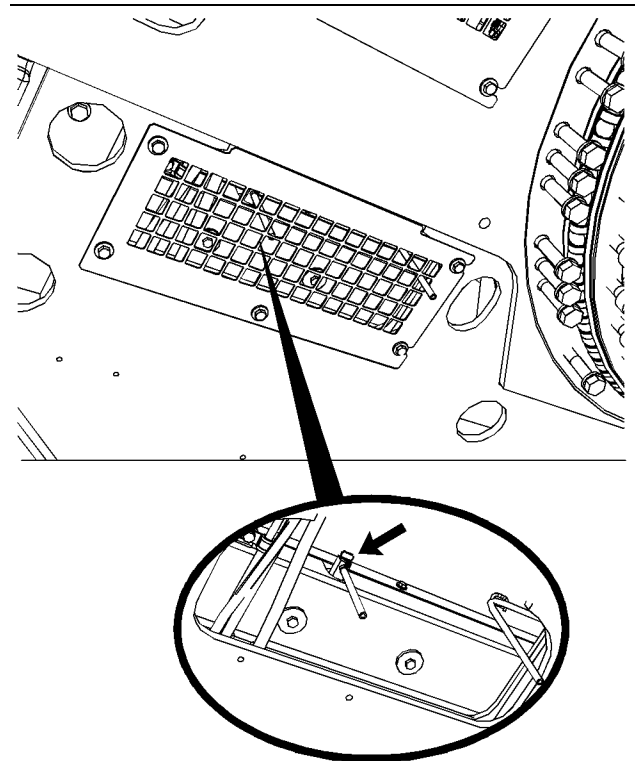

Illustration 409

g06011594

6. Open the drain valve and allow the coolant to drain into a suitable container. The drain valve is located on the bottom of the radiator.
7. Flush the cooling system. Follow Step 7a through Step 7h in order to flush the cooling system.
 - a. Close the drain valve.
 - b. Fill the cooling system with clean water.
 - c. Install the pressure cap.
 - d. Start the engine and run the engine until the engine reaches operating temperature.
 - e. Stop the engine and allow the engine to cool.
 - f. Loosen the pressure cap slowly in order to relieve any pressure in the cooling system.
 - g. Open the drain valve that is on the bottom of the radiator and allow the coolant to drain into a suitable container.
 - h. Flush the radiator with clean water until the draining water is transparent.
8. Close the drain valve.
9. Add the Extended Life Coolant. Refer to the following topics:

- Special Publication, SEBU6250, "Caterpillar Machine Fluids Recommendations"
- Operation and Maintenance Manual, "Capacities (Refill)"

i04064549

- 10.** After the cooling system has been filled, perform the following procedures during initial start-up:
- Start the engine without the filler cap.
 - Run the engine at low idle for 10 minutes.
 - Then, increase the engine speed to a high idle until the water temperature regulator is open and the coolant level is stabilized.
 - Maintain the coolant at the proper level as the water temperature regulator opens and the air is purged from the system. Refer to Operation and Maintenance Manual, "Cooling System Coolant Level - Check".
- 11.** Install the cooling system pressure cap.
- 12.** Stop the engine.

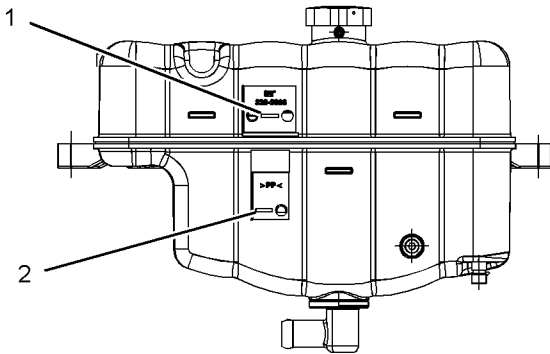

Illustration 410

g02153074

- (1) "FULL"
(2) "LOW"

- 13.** Check the coolant reservoir. Maintain the coolant level between "FULL" mark (1) and "LOW" mark (2).
- 14.** If additional coolant is necessary, remove the pressure cap and add the appropriate coolant solution.
- 15.** Install the pressure cap.
- 16.** Close the engine hood and latch the engine hood. Install the cover.

Cooling System Coolant Extender (ELC) - Add

SMCS Code: 1352; 1353; 1395

WARNING

Engine hood and engine hood parts can be hot while engine is running or immediately after engine shutdown. Hot parts or hot components can cause burns or personal injury. Do not allow these parts to contact your skin, when engine is running or immediately after engine shutdown. Use protective clothing or protective equipment to protect your skin.

WARNING

Personal injury can result from hot coolant, steam and alkali.

At operating temperature, engine coolant is hot and under pressure. The radiator and all lines to heaters or the engine contain hot coolant or steam. Any contact can cause severe burns.

Remove cooling system pressure cap slowly to relieve pressure only when engine is stopped and cooling system pressure cap is cool enough to touch with your bare hand.

Do not attempt to tighten hose connections when the coolant is hot, the hose can come off causing burns.

Cooling System Coolant Additive contains alkali. Avoid contact with skin and eyes.

Use Cat Extended Life Coolant (ELC) when you add coolant to the cooling system. See Special Publication, SEBU6250, "Caterpillar Machine Fluids Recommendations" for all cooling system requirements.

Use a Coolant Conditioner Test Kit in order to check the concentration of the coolant.

NOTICE

Mixing ELC with other products will reduce the effectiveness of the coolant.

This could result in damage to cooling system components.

If Caterpillar products are not available and commercial products must be used, make sure they have passed the Caterpillar EC-1 specification for pre-mixed or concentrate coolants and Caterpillar Extender.

Note: This machine was filled at the factory with Cat Extended Life Coolant.

i04047486

1. Park the machine on level ground.
2. Stop the engine.
3. Unlatch the engine hood and raise the engine hood.

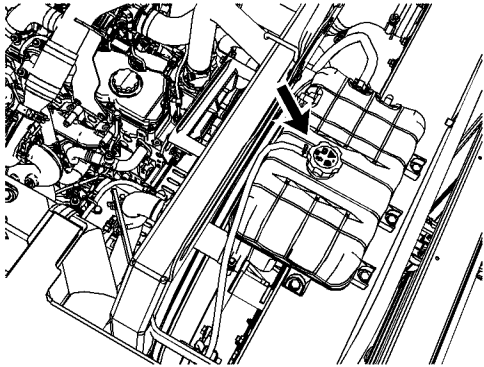

Illustration 411

g02153073

4. Make sure that the cooling system has cooled down. Loosen the cooling system pressure cap slowly in order to relieve system pressure. Remove the pressure cap.

Note: Refer to Operation and Maintenance Manual, "General Hazard Information" for information on containing fluid spillage.

5. You may need to drain some coolant from the radiator so that Cat Extender can be added to the cooling system.

Note: Always discard drained fluids according to local regulations.

6. Add Cat Extended Life Coolant (ELC) to the cooling system. Refer to the following topics for the proper amount of Cat Extender:

- Special Publication, SEBU6250, "Caterpillar Machine Fluids Recommendations"
- Operation and Maintenance Manual, "Capacities (Refill)"

7. Inspect the o-ring of the cooling system pressure cap. If the o-ring is damaged, replace the pressure cap.
8. Install the cooling system pressure cap.
9. Close the engine hood and latch the engine hood.

Cooling System Coolant Level - Check

SMCS Code: 1350-040; 1350-535-FLV; 1395-535-FLV

WARNING

Engine hood and engine hood parts can be hot while engine is running or immediately after engine shutdown. Hot parts or hot components can cause burns or personal injury. Do not allow these parts to contact your skin, when engine is running or immediately after engine shutdown. Use protective clothing or protective equipment to protect your skin.

WARNING

Personal injury can result from hot coolant, steam and alkali.

At operating temperature, engine coolant is hot and under pressure. The radiator and all lines to heaters or the engine contain hot coolant or steam. Any contact can cause severe burns.

Remove cooling system pressure cap slowly to relieve pressure only when engine is stopped and cooling system pressure cap is cool enough to touch with your bare hand.

Do not attempt to tighten hose connections when the coolant is hot, the hose can come off causing burns.

Cooling System Coolant Additive contains alkali. Avoid contact with skin and eyes.

1. Unlatch the engine hood and raise the engine hood.

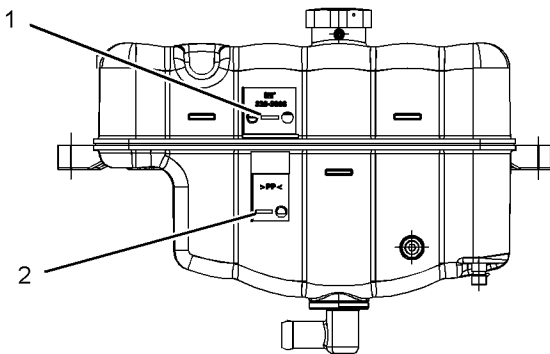

Illustration 412

g02153074

i06534876

- (1) "FULL" level
(2) "LOW" level

2. Check the coolant level of the coolant reservoir when the engine is cold. Maintain the coolant level between the "FULL" mark and the "LOW" mark. If the coolant reservoir is empty, follow Steps 2a through 2g.

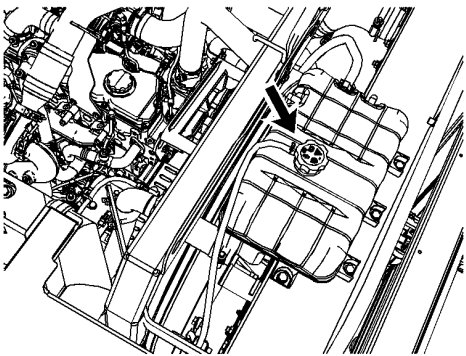

Illustration 413

g02153073

- a. Slowly loosen the cooling system pressure cap in order to relieve system pressure. Remove the pressure cap.

Note: Refer to Operation and Maintenance Manual, "General Hazard Information" for information on containing fluid spillage.

- b. Add the appropriate coolant solution to the cooling system. Refer to the following topics:
- Special Publication, SEBU6250, "Caterpillar Machine Fluids Recommendations"
 - Operation and Maintenance Manual, "Capacities (Refill)"

- c. Start the engine. Operate the engine without the cooling system pressure cap until the water temperature regulator opens and the coolant level stabilizes.
- d. Inspect the condition of the o-ring on the pressure cap. If the o-ring is damaged, replace the pressure cap.
- e. Install the cooling system pressure cap.
- f. Stop the engine.
- g. Close the engine hood and latch the engine hood.

Cooling System Coolant Sample (Level 1) - Obtain

SMCS Code: 1395-554; 1395-008; 7542

WARNING

Personal injury can result from hot coolant, steam and alkali.

At operating temperature, engine coolant is hot and under pressure. The radiator and all lines to heaters or the engine contain hot coolant or steam. Any contact can cause severe burns.

Remove filler cap slowly to relieve pressure only when engine is stopped and radiator cap is cool enough to touch with your bare hand.

Do not attempt to tighten hose connections when the coolant is hot, the hose can come off causing burns.

Cooling System Conditioner contains alkali. Avoid contact with skin and eyes.

Note: It is not necessary to obtain a Coolant Sample (Level 1) if the cooling system is filled with Cat ELC (Extended Life Coolant). Cooling systems that are filled with Cat ELC should have a Coolant Sample (Level 2) that is obtained at the recommended interval that is stated in the Maintenance Interval Schedule.

Note: Obtain a Coolant Sample (Level 1) if the cooling system is filled with any other coolant instead of Cat ELC. This includes the following types of coolants.

- Commercial long life coolants that meet the Caterpillar Engine Coolant Specification -1 (Caterpillar EC-1)
- Cat Diesel Engine Antifreeze/Coolant (DEAC)

Maintenance Section
Cooling System Coolant Sample (Level 2) - Obtain

- Commercial heavy-duty coolant/antifreeze

NOTICE

Always use a designated pump for oil sampling, and use a separate designated pump for coolant sampling. Using the same pump for both types of samples may contaminate the samples that are being drawn. This contamination may cause a false analysis and an incorrect interpretation that could lead to concerns by both dealers and customers.

NOTICE

Care must be taken to ensure that fluids are contained during performance of inspection, maintenance, testing, adjusting, and repair of the product. Be prepared to collect the fluid with suitable containers before opening any compartment or disassembling any component containing fluids.

Refer to Special Publication, PERJ1017, "Dealer Service Tool Catalog" for tools and supplies suitable to collect and contain fluids on Cat® products.

Dispose of all fluids according to local regulations and mandates.

Note: Level 1 results may indicate a need for Level 2 Analysis.

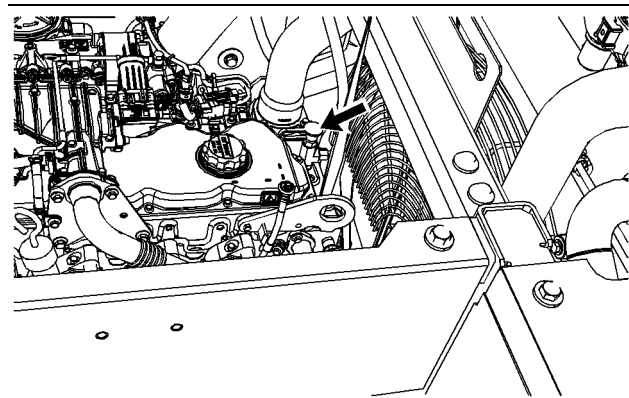

Illustration 414

g06011522

Obtain the sample of the coolant as close as possible to the recommended sampling interval. To receive the full effect of S·O·S analysis, establish a consistent trend of data. To establish a pertinent history of data, perform consistent samplings that are evenly spaced. Supplies for collecting samples can be obtained from your Caterpillar dealer.

Use the following guidelines for proper sampling of the coolant:

- Complete the information on the label for the sampling bottle before you begin to take the samples.

- Keep the unused sampling bottles stored in plastic bags.
- Obtain coolant samples directly from the coolant sample port. You should not obtain the samples from any other location.
- Obtain the coolant sample while the engine is running.
- Obtain the coolant sample while the coolant is at operating temperature.
- Keep the lids on empty sampling bottles until you are ready to collect the sample.
- Place the sample in the mailing tube immediately after obtaining the sample to avoid contamination.
- Never collect samples from expansion bottles.
- Never collect samples from the drain for a system.

Submit the sample for Level 1 analysis.

For additional information about coolant analysis, see Special Publication, SEBU6250, "Caterpillar Machine Fluids Recommendations" or consult your Cat dealer.

i07349178

Cooling System Coolant Sample (Level 2) - Obtain

SMCS Code: 1395-008; 1395-554; 7542

Reference: Refer to Operation and Maintenance Manual, "Cooling System Coolant Sample (Level 1) - Obtain" for the guidelines for proper sampling of the coolant.

Obtain the sample of the coolant as close as possible to the recommended sampling interval. Supplies for collecting samples can be obtained from your Cat dealer.

Submit the sample for Level 2 analysis.

Reference: For additional information about coolant analysis, refer to Special Publication, SEBU6250, "Caterpillar Machine Fluids Recommendations" or consult your Cat dealer.

i07400074

DEF Filler Screen - Clean (Emission Related Component)

SMCS Code: 108K-070-Z3

NOTICE

Ensure that the engine is stopped before any servicing or repair is performed.

NOTICE

Care must be taken to ensure that fluids are contained during performance of inspection, maintenance, testing, adjusting, and repair of the product. Be prepared to collect the fluid with suitable containers before opening any compartment or disassembling any component containing fluids.

Refer to Special Publication, NENG2500, "Cat Dealer Service Tool Catalog" or refer to Special Publication, PECJ0003, "Cat Shop Supplies and Tools Catalog" for tools and supplies suitable to collect and contain fluids on Cat products.

Dispose of all fluids according to local regulations and mandates.

The filler neck adapter filter screen in the diesel exhaust fluid tank will need to be cleaned or replaced if contaminated.

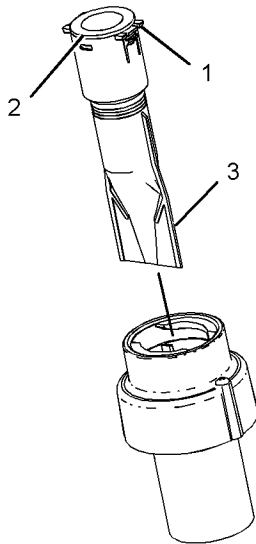

Illustration 415

g03618438

1. Use a screwdriver or pick to press the tabs (1).
2. Pull the screen assembly (2) upward from both sides and remove from the fill neck adapter
3. Use water or compressed air to clean out the filter screen (3). If there is any debris inside, let dry and remove the debris by turning the screen upside down and dumping debris out. If the debris cannot be removed or the filter screen is damaged, replace the filler neck adapter filter screen.

i07443771

DEF Manifold Filters - Replace (Emission Related Component)

SMCS Code: 108K-510-FI

NOTICE

Ensure that the engine is stopped before any servicing or repair is performed.

NOTICE

Care must be taken to ensure that fluids are contained during performance of inspection, maintenance, testing, adjusting, and repair of the product. Be prepared to collect the fluid with suitable containers before opening any compartment or disassembling any component containing fluids.

Refer to Special Publication, NENG2500, "Cat Dealer Service Tool Catalog" or refer to Special Publication, PECJ0003, "Cat Shop Supplies and Tools Catalog" for tools and supplies suitable to collect and contain fluids on Cat products.

Dispose of all fluids according to local regulations and mandates.

Note: Refer to Special Instruction, REHS8231, "Removal Procedures for Diesel Exhaust Fluid (DEF) Connectors" for the correct removal procedure of hose assemblies (1) and (5).

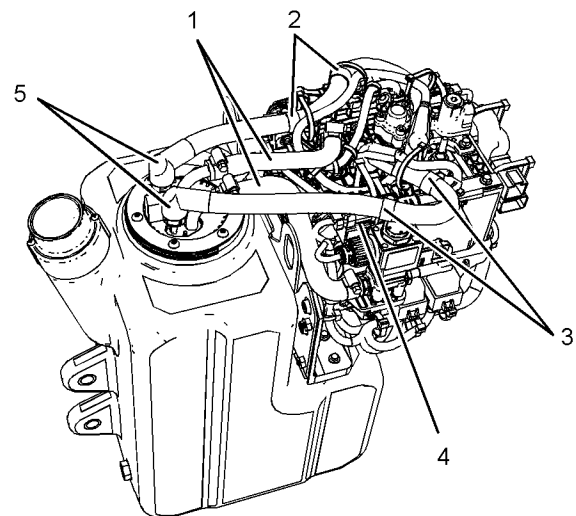

Illustration 416

g03662693

Typical Example

1. Clamp off hoses (1).

Maintenance Section
Emission Related Component

2. Remove clips (2) and (3). Disconnect harness assemblies (4). Remove hose assemblies (1) and (5).

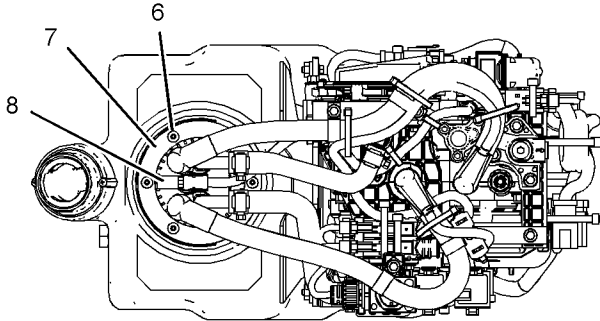

Illustration 417

g03665701

Typical Example

3. Remove bolts (6), plate (7), tank manifold (8), and gasket (not shown).

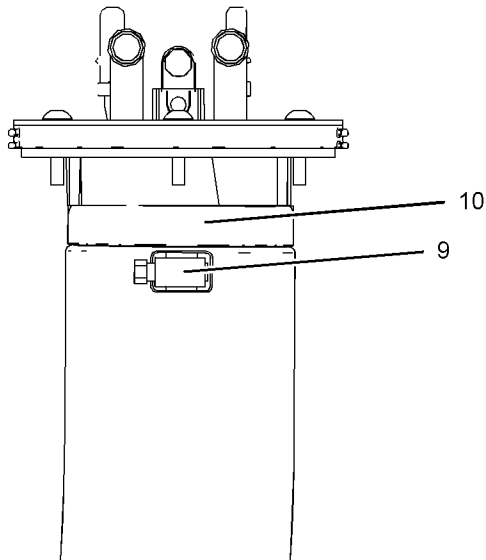

Illustration 418

g03665737

4. Unscrew the band clamp (9) and remove the band clamp from the filter base (10).

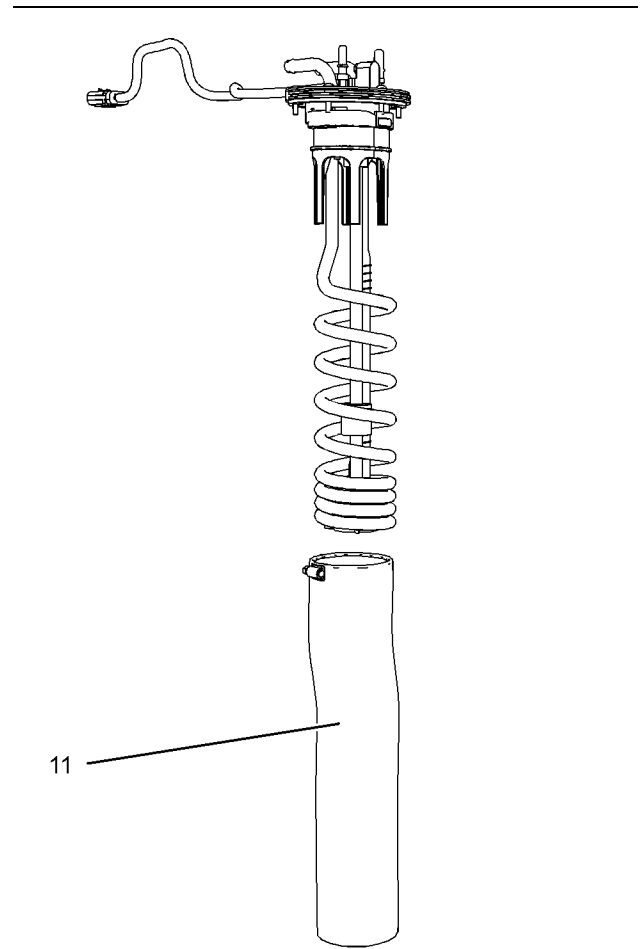

Illustration 419

g03664911

5. Remove the filter (11) from the filter base.

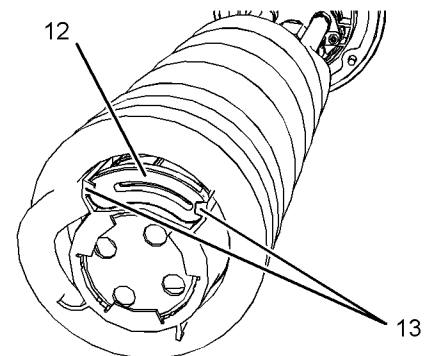

Illustration 420

g03666075

6. Remove the suction filter (12) at the bottom of the header coils by pulling tabs (13). Replace with a new suction filter.

7. Install new filter by pulling filter over the manifold coils up to the bottom of the assembled filter base.

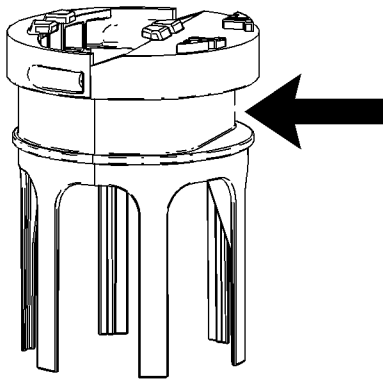

Illustration 421

g03665754

8. Tighten the band clamp 4.5 ± 0.7 N·m (40 ± 6 lb in), ensuring that the band clamp is aligned, as shown in illustration 421, to the flat spot on the base. Ensure that the filter does not bunch when tightening the band clamp.
9. Install the tank manifold following steps 3 through 5 in reverse order with a new gasket.
10. Tighten bolts (6) in an alternating sequence to 5 ± 1 N·m (44 ± 9 lb in). Tighten bolts (6) a second time in an alternating sequence to 5 ± 1 N·m (44 ± 9 lb in). Apply rubber lubricant to the o-ring seal inside of hose assemblies (1).

i05338005

Diesel Exhaust Fluid Filter - Replace

SMCS Code: 108K-510-FI

The Diesel Exhaust Fluid (DEF) filter is located on the DEF tank. The DEF tank is located in the tool box on the right side of the machine.

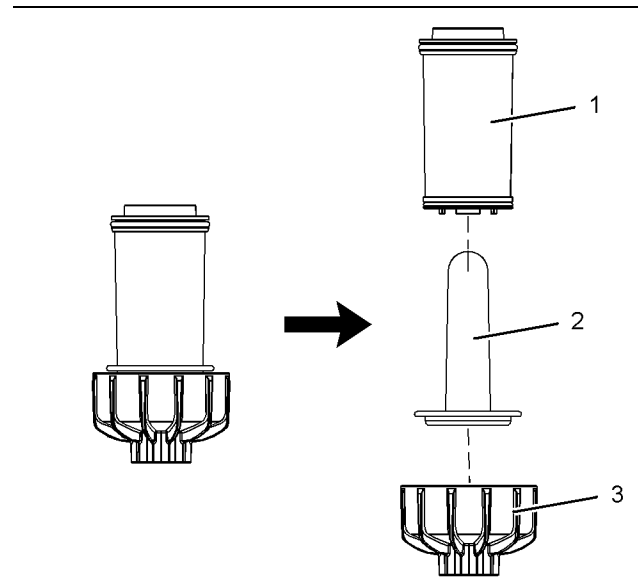

Illustration 422

g03332612

Typical Example

NOTICE

Ensure that the engine is stopped before any servicing or repair is performed.

NOTICE

Care must be taken to ensure that fluids are contained during performance of inspection, maintenance, testing, adjusting, and repair of the product. Be prepared to collect the fluid with suitable containers before opening any compartment or disassembling any component containing fluids.

Refer to Special Publication, NENG2500, "Cat Dealer Service Tool Catalog" or refer to Special Publication, PECJ0003, "Cat Shop Supplies and Tools Catalog" for tools and supplies suitable to collect and contain fluids on Cat products.

Dispose of all fluids according to local regulations and mandates.

1. Remove the diesel exhaust fluid (DEF) filter cap (3) with a 27 mm (1.06 inch) wrench.
2. Remove the rubber cone insert (2) from the DEF filter (1).

i05872079

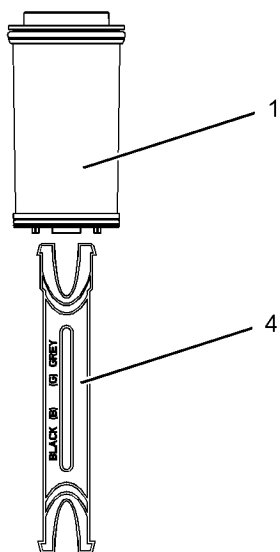

Illustration 423

g03332637

Typical Example

3. Insert the DEF filter removal tool (4) into the DEF filter (1) and remove the DEF filter (1).

Note: Wear gloves when you handle the DEF filter removal tool (4).

4. Clean the area around the filter housing.
5. Apply a thin coat of 207 - 1601 Lubricant to the seals of the new DEF filter (1).
6. Install new DEF filter (1) and rubber cone insert. Torque the filter to 20 ± 5 N·m (14.8 ± 3.7 lb ft) with a 27 mm (1.06 inch) wrench.

Diesel Exhaust Fluid Injector - Replace

SMCS Code: 108I-510

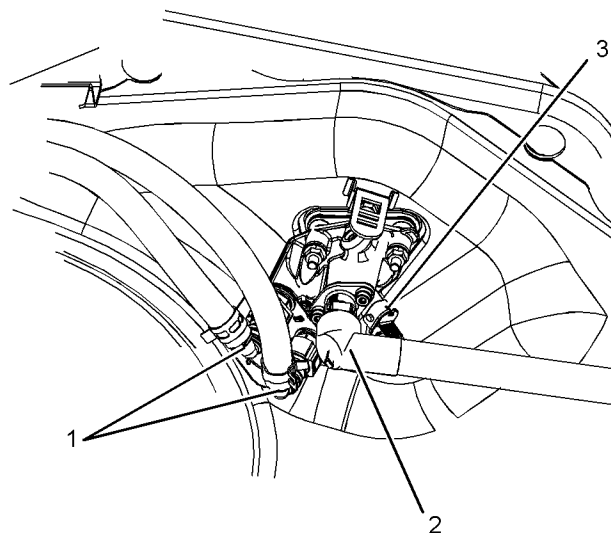

Illustration 424

g03418548

Typical example

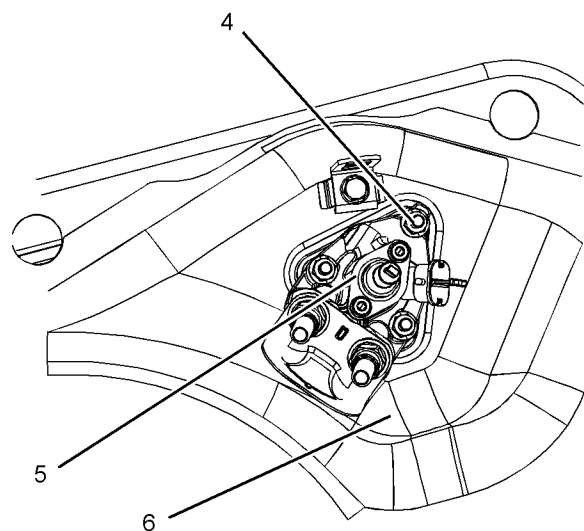

Illustration 425

g03418553

Typical example

1. Drain the coolant in order to remove the coolant lines (1). Remove the cooling lines (1) and remove Diesel Exhaust Fluid (DEF) line (2).

- Remove electrical connect from position (3) and install protection caps to DEF injector (5). Remove nuts (4) and washers (9) from DEF injector (5) and remove DEF injector from Clean Emission Module (CEM) (6).

If available, using the electronic service tool (ET) perform DEF Dosing System Verification test.

i07143042

Diesel Exhaust Fluid - Fill

SMCS Code: 108K-544

Note: Stop the engine and turn the key to the OFF position before filling the DEF tank. Failure to stop the engine may cause fault codes.

Refer to Operation and Maintenance Manual, "Selective Catalytic Reduction Warning System" for more information.

NOTICE

Care must be taken to ensure that fluids are contained during performance of inspection, maintenance, testing, adjusting, and repair of the machine. Be prepared to collect the fluid with suitable containers before opening any compartment or disassembling any component containing fluids.

Dispose of all fluids according to local regulations and mandates.

Reference: See Operation and Maintenance Manual, "Capacities (Refill)" for the capacity of the DEF tank for your machine.

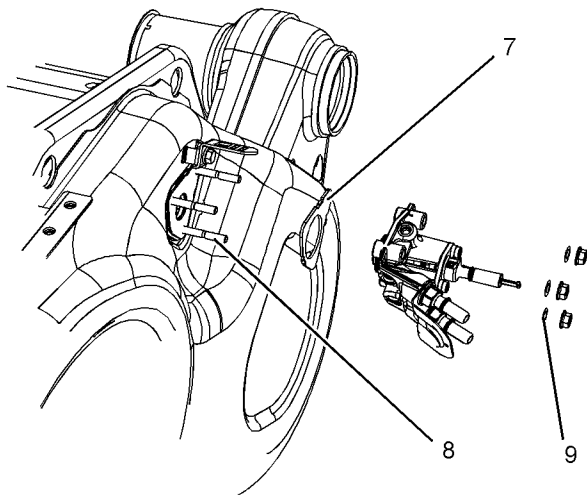

Illustration 426

g03418578

Typical example

- Remove gasket (7) and remove the studs (8). Discard the gasket and the studs.
- Ensure that the sealing face of the CEM is clean and free from dirt.
- Apply bostik pure nickel ant-seize compound to ends of the new studs (8). Install the coated ends of the new studs into the CEM, and tighten to a torque of 5 N·m (44 lb in).
- Install new gasket (7), ensure that the metal side of the gasket is to the CEM. Install new DEF injector (5) to CEM (6).
- Install washers (9) and apply bostik pure nickel ant-seize compound to the threads of the studs (8).
- Install the nuts (4) and tighten the nuts to a torque of 5 N·m (44 lb in). Retighten the nuts to 5 N·m (44 lb in). Then, turn the nuts additional 90 degrees.
- Install electrical connection into position (3) and install DEF line (2). Install coolant lines (1).
- Fill cooling system to the correct level. Ensure that the correct specification of coolant is used.

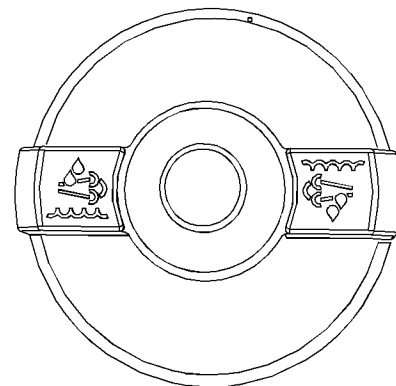

Illustration 427

g03746390

Blue DEF Tank Filler Cap

Maintenance Section
 Engine Air Filter Primary Element - Clean/Replace

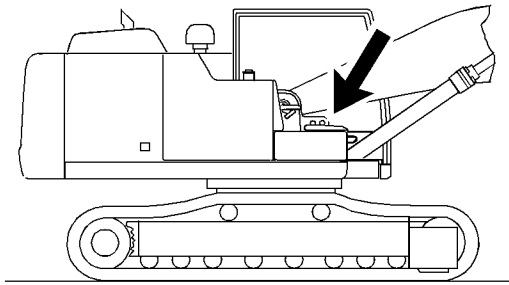

Illustration 428

g03419017

The DEF tank is located inside the storage box on the right side of the machine.

1. Clean the blue DEF tank filler cap and the surrounding area.
2. Remove the blue DEF tank filler cap.
3. Fill the tank with diesel exhaust fluid (DEF).

Note: Do not fill the DEF tank from a contaminated container or funnel.

Note: Do not over fill the tank. DEF can freeze and needs room for expansion.

4. Install the blue DEF tank filler cap.

Refer to Operation and Maintenance Manual, "Lubricant Viscosities" for more information on diesel exhaust fluid (DEF) guidelines.

i02530911

Engine Air Filter Primary Element - Clean/Replace

SMCS Code: 1054-070; 1054-510

If a warning and a pictograph is displayed on the message display or if the exhaust is black, check the primary filter.

1. Open both access doors on the left side of the machine.

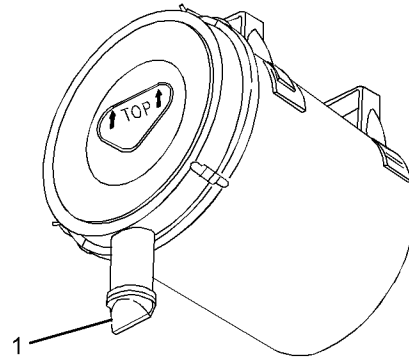

Illustration 429

g01266485

2. Squeeze the outlet tube (1) slightly in order to purge the dirt from the outlet tube.

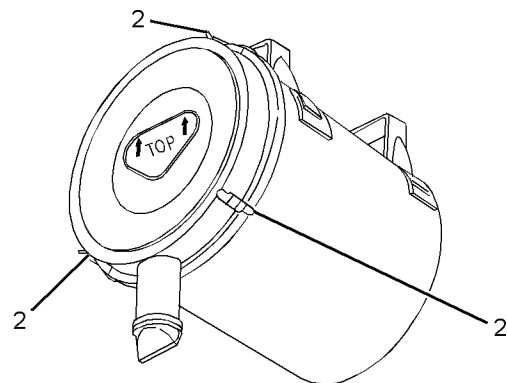

Illustration 430

g01266486

3. Loosen the cover latches (2) and remove the air cleaner cover.

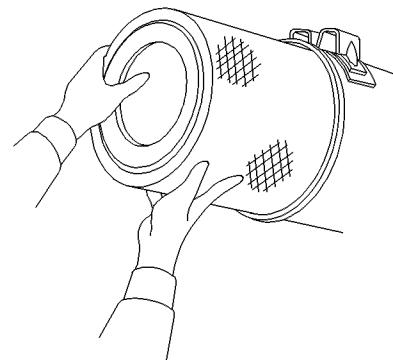

Illustration 431

g00101415

4. Remove the primary filter element from the air cleaner housing.

5. Clean the air cleaner cover and the inside of the air cleaner housing.
6. Inspect the O-ring seal on the air cleaner cover.
Replace the O-ring seal if the O-ring seal is worn or damaged.
7. Install the clean primary filter.

Note: Refer to “Cleaning Primary Air Filter Elements”.

8. Install the air cleaner cover and close the latches securely.



Illustration 432

g00101416

Note: Install the air cleaner cover properly. The arrows must point upward.

9. Change the filter if any of the following conditions occurs:
 - Restricted Air Filter indicator on the monitor panel still comes on.
 - Exhaust smoke is still black after the installation of a primary filter.
10. Close the access doors.

Cleaning Primary Air Filter Elements

NOTICE

Caterpillar recommends certified air filter cleaning services available at participating Caterpillar dealers. The Caterpillar cleaning process uses proven procedures to assure consistent quality and sufficient filter life.

Observe the following guidelines if you attempt to clean the filter element:

Do not tap or strike the filter element in order to remove dust.

Do not wash the filter element.

Use low pressure compressed air in order to remove the dust from the filter element. Air pressure must not exceed 207 kPa (30 psi). Direct the air flow up the pleats and down the pleats from the inside of the filter element. Take extreme care in order to avoid damage to the pleats.

Do not use air filters with damaged pleats, gaskets, or seals. Dirt entering the engine will cause damage to engine components.

When the primary air filter element is cleaned, check for rips or tears in the filter material. Replace the primary air filter element after the primary air filter element has been cleaned six times. The primary air filter element should be replaced at least one time per year. This replacement should be performed regardless of the number of cleanings.

NOTICE

Do not clean the air filter elements by bumping or tapping. This could damage the seals. Do not use elements with damaged pleats, gaskets, or seals. Damaged elements will allow dirt to pass through. Engine damage could result.

Visually inspect the primary air filter elements before cleaning. Inspect the air filter elements for damage to the seal, the gaskets, and the outer cover. Discard any damaged air filter elements.

There are two common methods that are used to clean primary air filter elements:

- Pressurized air
- Vacuum cleaning

Pressurized Air

Pressurized air can be used to clean primary air filter elements that have not been cleaned more than two times. Pressurized air will not remove deposits of carbon and oil. Use filtered, dry air with a maximum pressure of 207 kPa (30 psi).

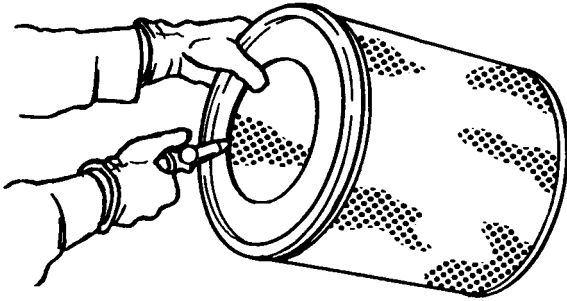

Illustration 433

g00281692

Note: When the primary air filter elements are cleaned, always begin with the clean side (inside) in order to force dirt particles toward the dirty side (outside).

Aim the hose so that the air flows inside the element along the length of the filter in order to help prevent damage to the paper pleats. Do not aim the stream of air directly at the primary air filter element. Dirt could be forced further into the pleats.

Vacuum Cleaning

Vacuum cleaning is another method for cleaning primary air filter elements which require daily cleaning because of a dry, dusty environment. Cleaning with pressurized air is recommended prior to vacuum cleaning. Vacuum cleaning will not remove deposits of carbon and oil.

Inspecting the Primary Air Filter Elements

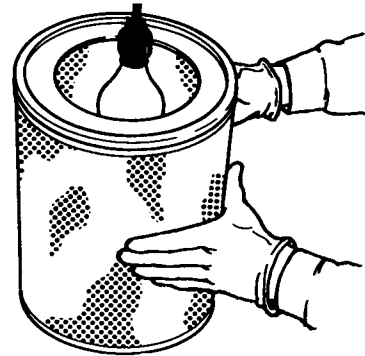

Illustration 434

g00281693

Inspect the clean, dry primary air filter element. Use a 60 watt blue light in a dark room or in a similar facility. Place the blue light in the primary air filter element. Rotate the primary air filter element. Inspect the primary air filter element for tears and/or holes. Inspect the primary air filter element for light that may show through the filter material. If it is necessary in order to confirm the result, compare the primary air filter element to a new primary air filter element that has the same part number.

Do not use a primary air filter element that has any tears and/or holes in the filter material. Do not use a primary air filter element with damaged pleats, gaskets or seals. Discard damaged primary air filter elements.

Storing Primary Air Filter Elements

If a primary air filter element that passes inspection will not be used, the primary air filter element can be stored for future use.

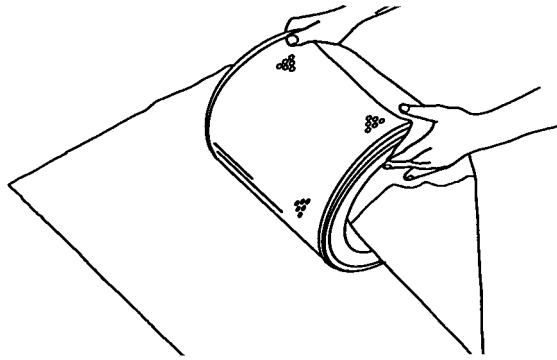

Illustration 435

g00281694

Do not use paint, a waterproof cover, or plastic as a protective covering for storage. An air flow restriction may result. To protect against dirt and damage, wrap the primary air filter elements in Volatile Corrosion Inhibited (VCI) paper.

Place the primary air filter element into a box for storage. For identification, mark the outside of the box and mark the primary air filter element. Include the following information:

- Date of cleaning
- Number of cleanings

Store the box in a dry location.

i05770379

Engine Air Filter Secondary Element - Replace

SMCS Code: 1054-510

NOTICE

Always replace the secondary filter element. Never attempt to reuse the secondary filter element by cleaning the element.

When the primary filter element is replaced, the secondary filter element should be replaced.

The secondary filter element should also be replaced if the air filter restriction warning appears on the message display after the installation of a clean primary filter element.

1. Open the access door on the front left side of the machine.
2. See Operation and Maintenance Manual, "Engine Air Filter Primary Element - Clean/Replace". Remove the air cleaner cover from the air cleaner housing. Remove the primary filter element from the air cleaner housing.

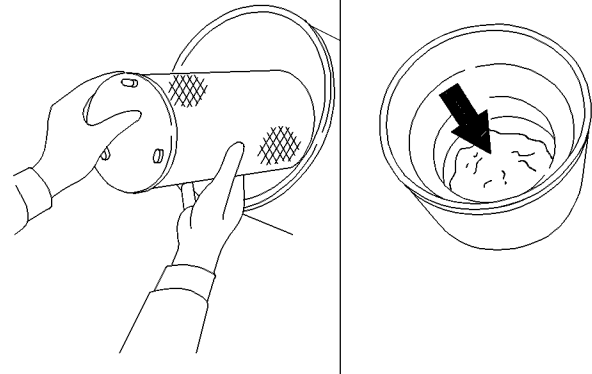

Illustration 436

g00101451

3. Remove the secondary filter element.
4. Cover the air inlet opening. Clean the inside of the air cleaner housing.
5. Remove the cover from the air inlet opening.
6. Install the new secondary filter element.
7. Install the primary filter element.
8. Install the air cleaner cover and close the latches securely.
9. Close the access door.

i04365872

Engine Oil Level - Check

SMCS Code: 1000-535

⚠ WARNING

Hot oil and hot components can cause personal injury. Do not allow hot oil or hot components to contact skin.

NOTICE

Do not overfill the crankcase. Engine damage can result.

Note: This machine is equipped with both an automated function for checking fluid levels and a dipstick. Refer to Operation and Maintenance Manual, "Monitoring System" regarding the automated system. If the machine is on an incline or the engine has been stopped only for a short time, the engine oil does not return to the crankcase and the fluid level cannot be properly checked by either method. Park the machine on level ground. The engine oil level can be checked after the engine has been stopped for at least 30 minutes.

Maintenance Section

Engine Oil Sample - Obtain

Check the oil level while the engine is stopped. Do not check the oil level while the engine is running.

1. Open the engine hood.

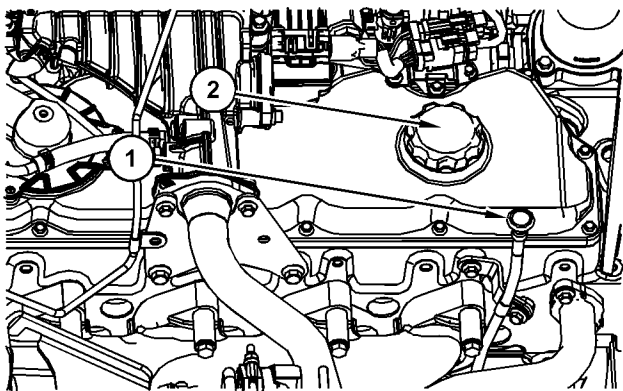

Illustration 437

g02519379

2. Remove dipstick (1). Wipe the oil off the dipstick and reinsert the dipstick.

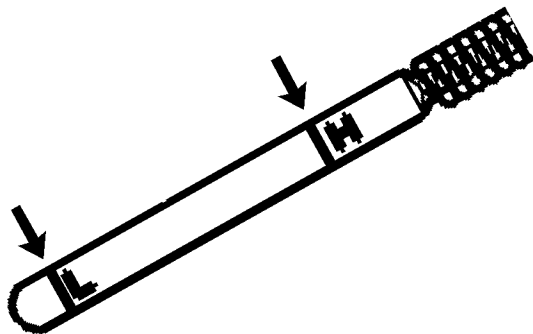

Illustration 438

g02153764

3. Remove the dipstick and check the dipstick. The oil level should be between the "L" mark and the "H" mark.

NOTICE

Operating your engine when the oil level is above the "H" mark could cause the crankshaft to dip into the oil. This could lead to excessively high oil temperatures which can reduce the lubricating characteristics of the oil, lead to bearing damage, and could result in loss of engine power.

Note: Refer to Operation and Maintenance Manual, "General Hazard Information" for information on Containing Fluid Spillage.

4. Remove oil filler plug (2) in order to add oil, if necessary. See Operation and Maintenance Manual, "Lubricant Viscosities".

Note: If the oil is deteriorated or badly contaminated, change the oil regardless of the maintenance interval.

5. Clean the oil filler plug. Install the oil filler plug.
6. Close the engine hood.

i05967309

Engine Oil Sample - Obtain

SMCS Code: 1000; 1000-008; 1348-554-SM; 1348-008; 7542-008; 7542-554-OC; 7542-554-SM

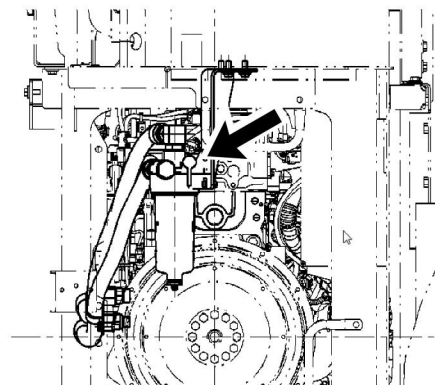

Illustration 439

g03741695

Obtain a sample of the engine oil from the engine oil sampling valve that is located on the engine oil filter housing. Refer to Special Publication, SEBU6250, "S·O·S Oil Analysis" for information that pertains to obtaining a sample of the engine oil. Refer to Special Publication, PEGJ0047, "How To Take A Good Oil Sample" for more information about obtaining a sample of the engine oil.

i07162251

Engine Oil and Filter - Change

SMCS Code: 1318-510

Selection of the Oil Change Interval

NOTICE

A 500 hour engine oil change interval is available, provided that the operating conditions and recommended multigrade oil types are met. When these requirements are not met, shorten the oil change interval to 250 hours, or use an S·O·S Services oil sampling and analysis program to determine an acceptable oil change interval.

If you select an interval for oil and filter change that is too long, you may damage the engine.

Note: Customers with a fuel burn average of 11.3 L (3 US gal) per hour or less may extend engine oil and filter interval from 500 hours to 1000 hours when utilizing Cat® fluids, filters and S·O·S Services.

Required oil sampling interval is every 250 hours.

Initial engine oil and filter change at 500 hours is required for engine break-in.

Cat oil filters are recommended.

Recommended multigrade oil types are listed in Table 58 . Do not use single grade oils.

Abnormally harsh operating cycles or harsh environments can shorten the service life of the engine oil. Arctic temperatures, corrosive environments, or dusty conditions may require a reduction in engine oil change intervals from the recommendations in Table 58 . Also refer to Special Publication, SEBU5898, "Cold Weather Recommendations for all Caterpillar Machines". Poor maintenance of air filters or of fuel filters requires reduced oil change intervals. See your Cat dealer for more information if this product will experience abnormally harsh operating cycles or harsh environments.

Table 58

Engine Oil Change Interval ⁽¹⁾			
Multigrade Oil Type	Operating Conditions		
	Normal ⁽²⁾	High Load Factor ⁽³⁾ above 26 L (7.0 US gal) per hr of fuel	Severe
			Altitude above 1830 m (6000 ft)
Cat DEO-ULS Recommended	500 hr	500 hr	250 hr ⁽⁴⁾
Cat ECF-1 11.0 minimum TBN	500 hr	500 hr	250 hr ⁽⁴⁾
Cat ECF-1 TBN below 11.0	500 hr	500 hr	250 hr ⁽⁴⁾

⁽¹⁾ The standard oil change interval in this machine is 500 hours, if the operating conditions and recommended oil types that are listed in this table are met. Improvements in the engine allow this engine oil change interval. This new standard interval is not permitted for other machines. Refer to the applicable Operation and Maintenance Manuals for the other machines.

⁽²⁾ Normal conditions include these factors: Fuel sulfur below 0.015%, altitude below 1830 m (6000 ft) and good air filter and fuel filter maintenance. Normal conditions do not include high load factor, harsh operating cycles, or harsh environments.

⁽³⁾ High load factors can shorten the service life of your engine oil. Continuous heavy load cycles and little idle time result in increased fuel consumption and oil contamination. These factors deplete the oil additives more rapidly. If the average fuel consumption of your engine exceeds 26 L (7.0 US gal) per hour, follow the "High Load Factor" recommendations in Table 58 . To determine average fuel consumption, measure average fuel consumption for 50 to 100 hours. If the application of the machine is changed, the average fuel consumption may change.

⁽⁴⁾ Use "Program B" below to determine an appropriate interval.

Adjustment of the Oil Change Interval

Note: Your Cat dealer has additional information on these programs.

Program A

Verification for an Oil Change Interval of 500 Hours

This program consists of three oil change intervals of 500 hours. Oil sampling and analysis are done at 250 hours and 500 hours for each of the three intervals for a total of six oil samples. The analysis includes oil viscosity and infrared (IR) analysis of the oil. If all of the results are satisfactory, the 500 hour oil change interval is acceptable for the machine in that application. Repeat Program A if you change the application of the machine.

If a sample does not pass the oil analysis, take one of these actions:

- Shorten the oil change interval to 250 hours.
- Proceed to Program B.
- Change to a preferred oil type in Table 58 .

Program B

Optimizing Oil Change Intervals

Begin with a 250 hour oil change interval. The oil change intervals are adjusted by increments. Each interval is adjusted an additional 50 hours. Periodic oil sampling and analysis are done during each interval. The analysis includes oil viscosity and infrared (IR) analysis of the oil. Repeat Program B if you change the application of the machine.

If an oil sample does not pass the analysis, shorten the oil change interval, or change to a preferred multigrade oil type in the listing above.

Procedure for Changing Engine Oil and Filter

WARNING

Hot oil and hot components can cause personal injury. Do not allow hot oil or hot components to contact skin.

Note: If the sulfur content in the fuel is greater than 1.5 percent by weight, use an oil that has a TBN of 30 and reduce the oil change interval by one-half.

Maintenance Section
Engine Oil and Filter - Change

Note: Drain the crankcase while the oil is warm. Warm oil allows waste particles that are suspended in the oil to drain. As the oil cools, the waste particles will settle to the bottom of the crankcase. The particles will not be removed by draining the oil and the particles will recirculate in the engine lubrication system with the new oil.

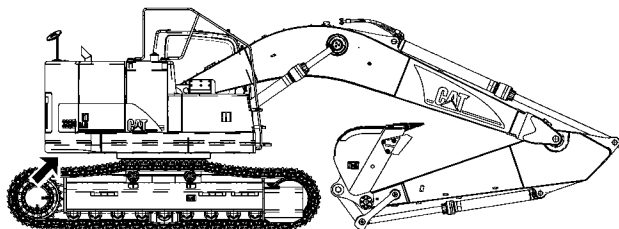

Illustration 440

g01257555

The drain valve for the engine crankcase oil is located under the rear of the upper structure.

1. Park the machine on a level surface. Stop the engine.

Note: Refer to Operation and Maintenance Manual, "General Hazard Information" for information on Containing Fluid Spillage.

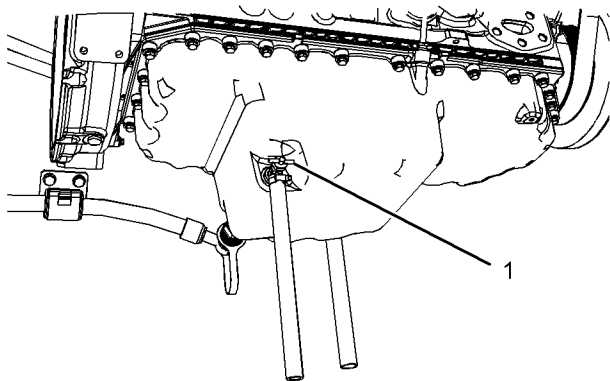

Illustration 441

g02154185

2. Open the crankcase drain valve (1). Allow the oil to drain into a suitable container.

Note: Discard any drained fluids according to local regulations.

3. Close the drain valve.
4. Open the access door at the right side of the machine.

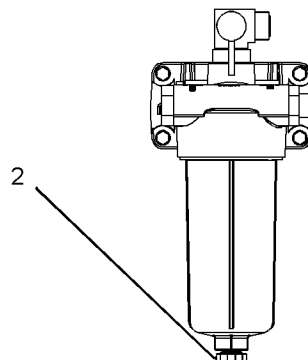

Illustration 442

g02157804

5. Loosen drain valve (2) and allow the oil to drain out of the housing.
6. After all the oil has been removed, tighten the drain.

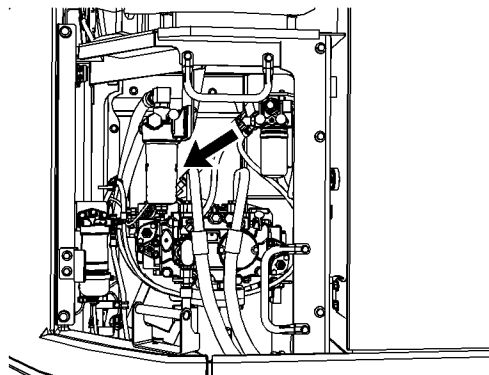

Illustration 443

g03742809

7. Remove the oil filter housing. See Operation and Maintenance Manual, "Oil Filter - Inspect". Dispose of the used filter according to local regulations.

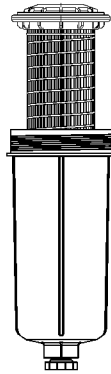

Illustration 444

g02157806

8. Remove the filter from the housing.
 9. Clean the filter housing and the base.
 10. Install the new filter element into the housing.
 11. Apply a thin coat of engine oil to the inner seal and outer seal of the filter.
 12. Install the engine oil filter by hand until the filter housing contacts the base.
- Note:** Tighten to 90 +5/0 N·m (66 + 4/0 lb ft).
13. Close the access door.
 14. Unlatch the engine hood and raise the engine hood.

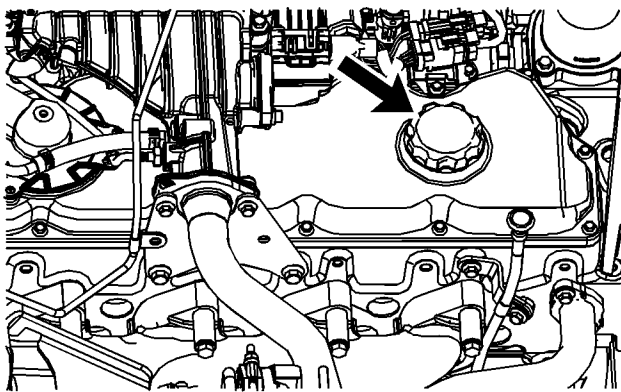

Illustration 445

g03711493

15. Remove the oil filler plug. Fill the crankcase with new oil. See Operation and Maintenance Manual, "Capacities (Refill)". Clean the oil filler plug and install the oil filler plug.

NOTICE

Do not under fill or overfill engine crankcase with oil. Either condition can cause engine damage.

16. Start the engine and allow the oil to warm. Check the engine for leaks. Stop the engine.

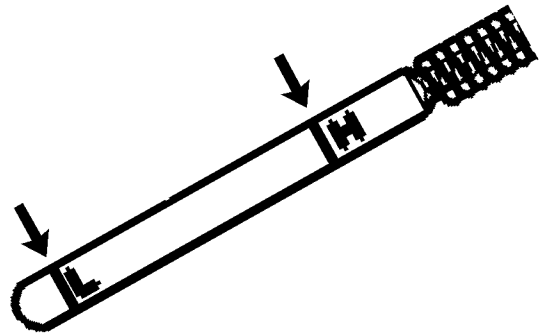

Illustration 446

g02153764

17. Wait for 30 minutes in order to allow the oil to drain back into the crankcase. Check the oil level with the dipstick. Maintain the oil between the "L" and "H" marks on the dipstick. If necessary, add oil.
18. Close the engine hood and latch the engine hood.

i07051358

Ether Starting Aid Cylinder - Replace

(If Equipped)

SMCS Code: 1456-510-CD

⚠ WARNING

Breathing ether vapors or repeated contact of ether with skin can cause personal injury. Personal injury may occur from failure to adhere to the following procedures.

Use ether only in well ventilated areas.

Do not smoke while changing ether cylinders.

Use ether with care to avoid fires.

Do not store replacement ether cylinders in living areas or in the operator's compartment.

Do not store ether cylinders in direct sunlight or at temperatures above 49 °C (120 °F).

Discard cylinders in a safe place. Do not puncture or burn cylinders.

Keep ether cylinders out of the reach of unauthorized personnel.

Maintenance Section
Final Drive Oil - Change

The ether cylinder is located inside the rear access door on the left side of the machine.

Refer to Operation and Maintenance, “Fire Prevention and Explosion Prevention” before you replace the ether cylinder.

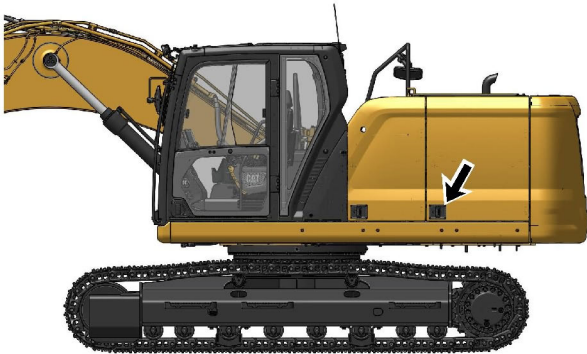

Illustration 447

g06179792

1. Open the rear access door at the left side of the machine.

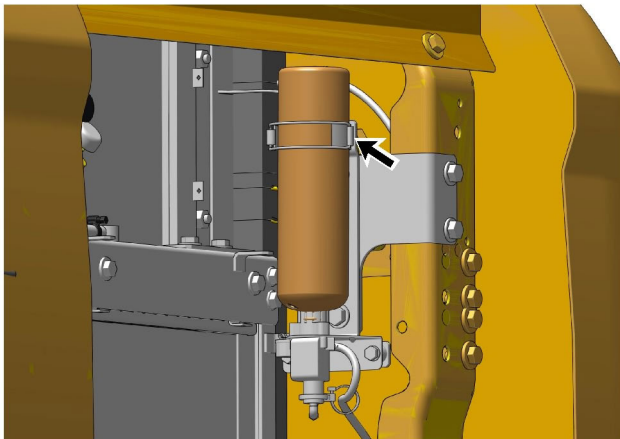

Illustration 448

g06211094

2. Loosen the cylinder retaining clamp.
3. Unscrew the empty ether starting aid cylinder and remove the empty ether starting aid cylinder.

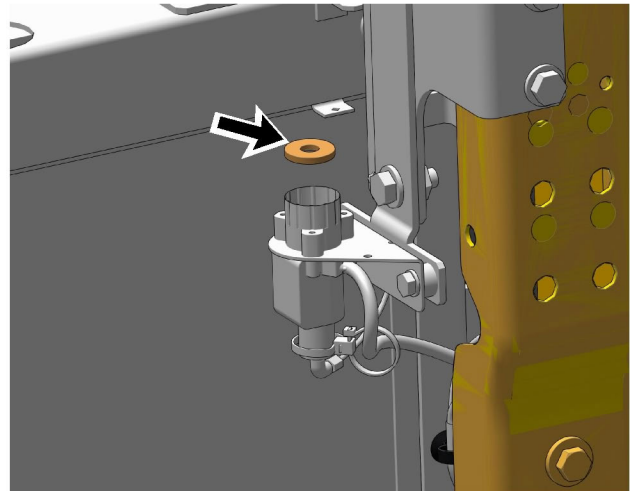

Illustration 449

g06211096

4. Remove the used gasket.
5. Install a new gasket.

Note: A new gasket and O-ring is provided with each new ether starting aid cylinder.

6. Install the new ether starting aid cylinder.
7. Tighten the ether starting aid cylinder hand tight.
8. Tighten the cylinder retaining clamp securely.
9. Close the access door.

i06882903

Final Drive Oil - Change

SMCS Code: 4050-044-FLV

WARNING

Hot oil and hot components can cause personal injury. Do not allow hot oil or hot components to contact skin.

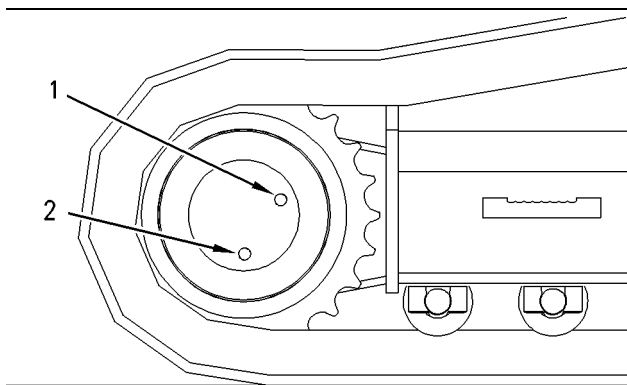

Illustration 450

g00822278

- (1) Oil level plug
(2) Oil drain plug

1. Position one final drive so that oil drain plug (2) is at the bottom.

Note: Refer to Operation and Maintenance Manual, "General Hazard Information" for information on Containing Fluid Spillage.

2. Remove drain plug (2) and level plug (1). Allow the oil to drain into a suitable container.
3. Clean the plugs and inspect the O-ring seals. If wear or damage is evident, replace the drain plug, the level plug, and/or the O-ring seals.
4. Install drain plug (2).
5. Fill the final drive to the bottom of the opening on level plug (1). See Operation and Maintenance Manual, "Lubricant Viscosities" and Operation and Maintenance Manual, "Capacities (Refill)".

Note: If the oil fills slowly, the fill hole may be blocked by the planetary gear. Rotate the final drive to move the planetary gear away from the fill hole.

Note: Overfilling the final drive will cause the seals on the travel motor to allow hydraulic oil or water to enter the final drive. The final drive may become contaminated.

6. Install level plug (1).
7. Perform Step 1 to Step 6 on the other final drive. Use a different container for the oil so that the oil samples from the final drives will be separate.
8. Completely remove the oil that has spilled onto surfaces.
9. Start the machine and allow the final drives to run through several cycles.
10. Stop the machine. Check the oil level.

11. Check the drained oil for metal chips or for particles. If there are any chips or particles, consult your Cat dealer.
12. Properly dispose of the drained material. Obey local regulations for the disposal of the material.

i03914051

Final Drive Oil Level - Check

SMCS Code: 4050-535-FLV

WARNING

Hot oil and hot components can cause personal injury. Do not allow hot oil or hot components to contact skin.

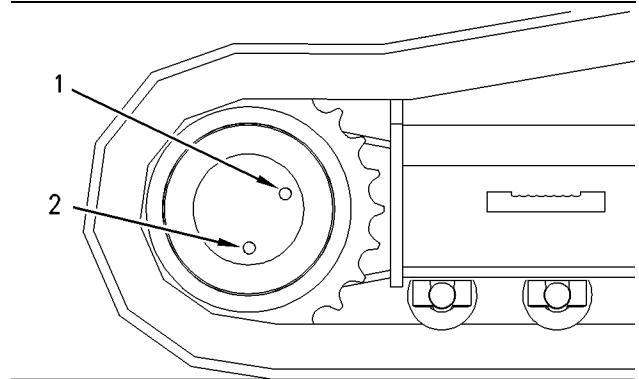

Illustration 451

g00822278

- (1) Oil level plug
(2) Oil drain plug

1. Position one final drive so that oil drain plug (2) is at the bottom.

Note: Refer to Operation and Maintenance Manual, "General Hazard Information" for information on Containing Fluid Spillage.

2. Remove oil level plug (1).
3. Check the oil level. The oil should be near the bottom of the level plug opening.
4. Add oil through the level plug opening, if necessary. See Operation and Maintenance, "Lubricant Viscosities".

Note: If the oil fills slowly, the fill hole may be blocked by the planetary gear. Rotate the final drive in order to move the planetary gear away from the fill hole.

Note: Overfilling the final drive will cause the seals on the travel motor to allow hydraulic oil or water to enter the final drive. The final drive may become contaminated.

Maintenance Section
Final Drive Oil Sample - Obtain

5. Clean oil level plug (1). Inspect the O-ring seal. Replace the O-ring seal if the O-ring seal is worn or damaged.
6. Install oil level plug (1).
7. Repeat the procedure for the other final drive.

i05966692

Final Drive Oil Sample - Obtain

SMCS Code: 4011-008; 4050-SM; 4050-008; 7542-008

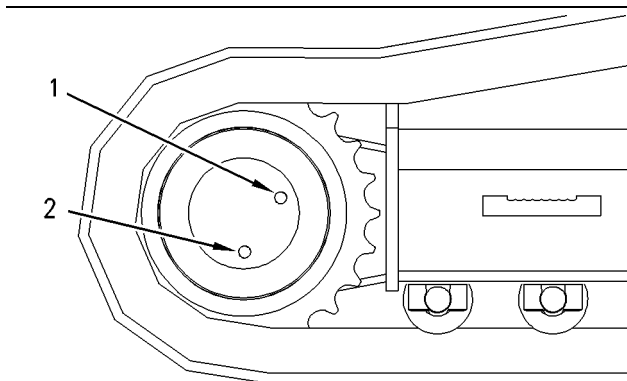

Illustration 452

g00822278

- (1) Oil level plug
(2) Oil drain plug

1. Position the final drive so that oil drain plug (2) is at the bottom.
2. Remove oil level plug (1).
3. Obtain a sample of the final drive oil through the hole for the oil level plug.
4. Install oil level plug (1).

Refer to Special Publication, SEBU6250, "S·O·S Oil Analysis" for more information on obtaining a sample of the final drive oil. For additional information about taking an oil sample, refer to Special Publication, PEGJ0047, "How To Take A Good Oil Sample".

i04255791

Fuel Lift Pump Strainer - Replace

SMCS Code: 1256; 1256-510-STR

WARNING

Personal injury or death may result from failure to adhere to the following procedures.

Fuel leaked or spilled onto hot surfaces or electrical components can cause a fire.

Clean up all leaked or spilled fuel. Do not smoke while working on the fuel system.

Turn the disconnect switch OFF or disconnect the battery when changing fuel filters.

NOTICE

Do not fill the fuel filters with fuel before installing the fuel filters. The fuel will not be filtered and could be contaminated. Contaminated fuel will cause accelerated wear to fuel system parts.

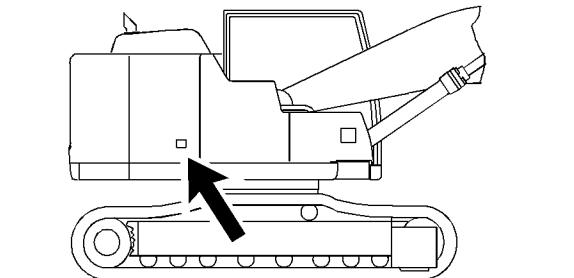

Illustration 453

g02415322

The fuel lift pump strainer is located behind the access door on the right side of the machine.

1. Open the access door on the right side of the machine.

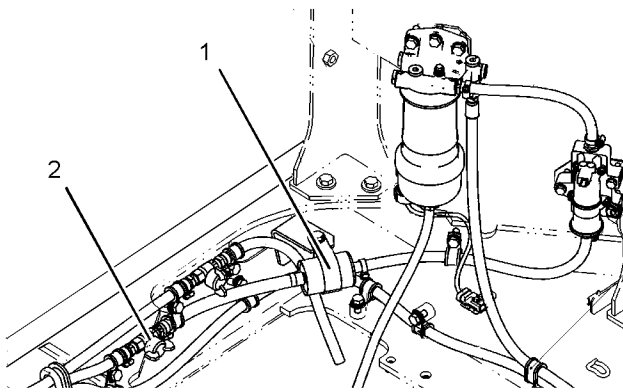

Illustration 454

g02426516

2. Close the fuel shut off valve (2) by turning the valve clockwise.
3. Disconnect the hoses from the strainer (1) and remove the strainer.
4. Replace the strainer.
5. Reconnect the hoses.
6. Open the fuel shut off valve (2) by turning the valve counterclockwise.
7. Replace the access cover that is underneath the fuel tank

i07318401

Fuel System - Prime

SMCS Code: 1250-548

WARNING

Fuel leaked or spilled onto hot surfaces or electrical components can cause a fire. To help prevent possible injury, turn the start switch off when changing fuel filters or water separator elements. Clean up fuel spills immediately.

NOTICE

Care must be taken to ensure that fluids are contained during performance of inspection, maintenance, testing, adjusting, and repair of the product. Be prepared to collect the fluid with suitable containers before opening any compartment or disassembling any component containing fluids.

Refer to Special Publication, PERJ1017, "Dealer Service Tool Catalog" for tools and supplies suitable to collect and contain fluids on Cat® products.

Dispose of all fluids according to local regulations and mandates.

NOTICE

Do not loosen the fuel lines at the fuel manifold. The fittings may be damaged and/or a loss of priming pressure may occur when the fuel lines are loosened.

NOTICE

Do not allow dirt to enter the fuel system. Thoroughly clean the area around a fuel system component that will be disconnected. Fit a suitable cover over any disconnected fuel system components.

Prime the fuel system to fill the fuel filter, and prime the fuel system to purge trapped air. The fuel system should be primed under the following conditions:

- The fuel tank is running low.
 - The machine has been stored.
 - The fuel filter is being replaced.
 - The fuel system has been repaired.
1. Turn the engine start switch to the ON position. Leave the engine start switch in the ON position for 4 minutes.
 2. Verify that the water separator is full of fuel.
 3. If the water separator is not full of fuel, turn the engine start switch OFF and then turn the engine start switch ON. Turning the engine start switch off and on will cycle the fuel priming pump again.
 4. When the water separator is full of fuel, attempt to start the engine. If the engine starts and the engine runs rough or the engine misfires, operate at low idle until the engine is running smoothly. If the engine cannot be started, or if the engine continues to misfire or smoke, repeat Step 1.

i06944065

Fuel System Primary Filter (Water Separator) Element - Replace

SMCS Code: 1263-510-FQ

WARNING

Personal injury or death may result from failure to adhere to the following procedures.

Fuel leaked or spilled onto hot surfaces or electrical components can cause a fire.

Clean up all leaked or spilled fuel. Do not smoke while working on the fuel system.

Turn the disconnect switch OFF or disconnect the battery when changing fuel filters.

NOTICE

Do not fill the fuel filters with fuel before installing the fuel filters. The fuel will not be filtered and could be contaminated. Contaminated fuel will cause accelerated wear to fuel system parts.

The primary filter/water separator is located behind the access door on the right side of the machine.

1. Open the access door on the right side of the machine.
2. Shut off the fuel supply. Refer to this Operation and Maintenance Manual, "Fuel Tank Shutoff and Drain Control" for additional information.

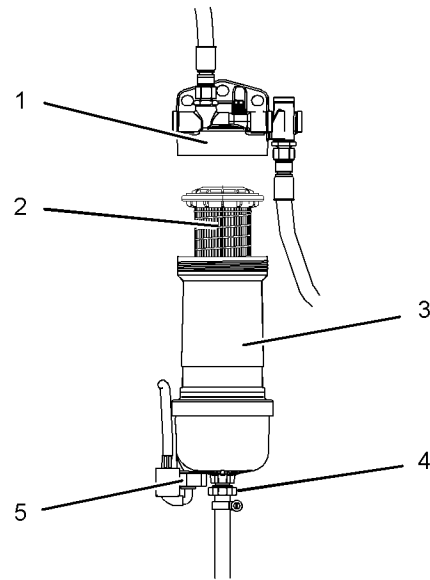

Illustration 455

g02241153

- (1) Filter base
- (2) Filter
- (3) Filter housing
- (4) Drain valve
- (5) Sensor

3. Turn drain valve (4) counterclockwise to open. The drain valve is located on the bottom of the water separator.

Note: Refer to Operation and Maintenance Manual, "General Hazard Information" for information that pertains to containing fluid spillage.

4. Drain the water and the sediment into a suitable container.

Note: Dispose of used fluids according to local regulations.

5. Close drain valve (4).
6. If equipped, remove the wiring harness from sensor (5) located on the bottom of the clear bowl.

Note: Do not attempt to remove the sediment bowl from the housing. The sediment bowl is permanently attached to the housing. Attempting to remove the sediment bowl may damage the bowl.

7. Remove filter housing (3) from filter base (1). A filter wrench may be used to loosen the filter housing.
8. Remove filter (2) from filter housing (3). Discard the used filter.
9. Clean the inside surfaces of the filter base and the filter housing.

10. Inspect the seal for damage. Replace the seal if the seal is damaged.
11. Lubricate the seal on the new filter with clean diesel fuel or lubricate the seal with clean motor oil.
12. Install the new filter into the filter housing (3). Tighten the filter housing to 10 N·m (7 lb ft), approximately 1/6 of a turn. Do not use tools to tighten the filter housing to the filter base.
13. If equipped, ensure that sensor (5) is in the correct position and install the wiring harness.
14. Close the access door.
15. Turn on the fuel supply. Refer to this Operation and Maintenance Manual, "Fuel Tank Shutoff and Drain Control" for additional information.

Note: Do not start the engine until all service to the fuel system is complete. For instructions about priming the fuel system, refer to Operation and Maintenance Manual, "Fuel System - Prime".

i05967199

Fuel System Secondary Filter - Replace

SMCS Code: 1261-510

WARNING

Personal injury or death can result from a fire.

Fuel leaked or spilled onto hot surfaces or electrical components can cause a fire.

Clean up all leaked or spilled fuel. Do not smoke while working on the fuel system.

Turn the disconnect switch OFF or disconnect the battery when changing fuel filters.

NOTICE

Do not fill fuel filters with fuel before installing them. Contaminated fuel will cause accelerated wear to fuel system parts.

NOTICE

Do not allow dirt to enter the fuel system. Thoroughly clean the area around a fuel system component that will be disconnected. Fit a suitable cover over any disconnected fuel system components.

1. Shut off the fuel supply. Refer to this Operation and Maintenance Manual, "Fuel Tank Shutoff and Drain Control" for additional information.

2. Open the rear access door on the left side of the machine.

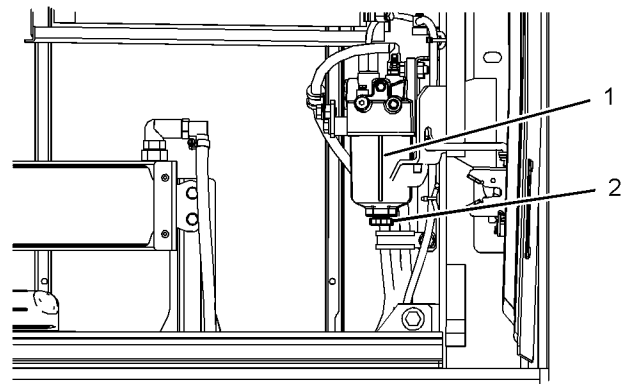

Illustration 456

g02158378

3. Loosen drain valve (2) and allow the fuel to drain out of the housing.

Note: Refer to Operation and Maintenance Manual, "General Hazard Information" for information on containing fluid spillage.

4. After all the fuel has been removed, tighten the drain.
5. Remove the secondary fuel filter housing (1) from the base.
6. Remove the filter element from the housing.
7. Clean the filter housing and the base.
8. Install the new filter element into the housing.
9. Apply a thin coat of clean diesel fuel to the sealing surface of the new fuel filter.
10. Install the new filter by hand until the filter housing contacts the base.
11. Turn on the fuel supply. Refer to this Operation and Maintenance Manual, "Fuel Tank Shutoff and Drain Control" for additional information.
12. Prime the fuel system. See Operation and Maintenance Manual, "Fuel System - Prime" for instructions.
13. Close the access door on the left side of the machine.

i06939612

i04421489

Fuel System Water Separator - Drain

SMCS Code: 1263

1. Open the access door on the right side of the machine.
2. Provide a suitable container for used fluid.

Note: Refer to Operation and Maintenance Manual, "General Hazard Information" for information on Containing Fluid Spillage.

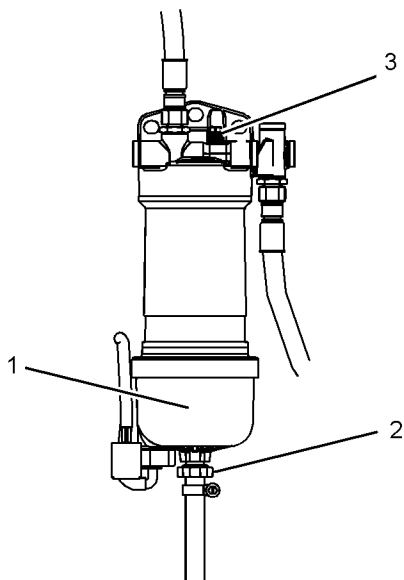

Illustration 457

g03049541

i04462462

- (1) Bowl
 (2) Drain valve
 (3) Breather valve

Note: Do not attempt to remove the sediment bowl from the housing. The sediment bowl is permanently attached to the housing. Attempting to remove the sediment bowl may damage the bowl.

3. Check bowl (1) in the bottom of the water separator. Open drain valve (2). Drain the water and sediment from the bowl.

Note: Dispose of used fluids according to local regulations.

Note: If the water is hard to drain, loosen breather valve (3) on the filter base.

4. Close drain valve (2).
5. Close the access door.

Fuel Tank Cap Filter - Replace

SMCS Code: 1273-510-FI; 1273-510-Z2

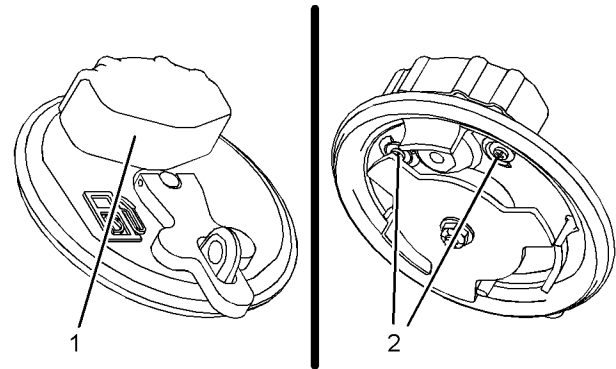

Illustration 458

g02612539

1. Remove the fuel cap.
2. Remove filter element screws (2) from the underside of the fuel cap and remove old filter element (1).
3. Wash the fuel tank cap in a clean, nonflammable solvent.
4. Install a new fuel cap filter element.
5. Install filter element screws (2) in order to secure filter element (1) to the fuel cap.
6. Install the fuel tank cap

Fuel Tank Strainer - Clean

SMCS Code: 1273-070-STR

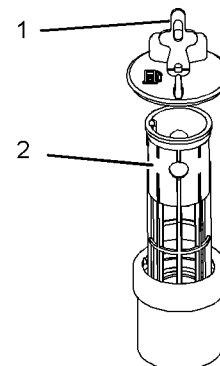

Illustration 459

g02609604

1. Remove fuel tank cap (1).

2. Remove strainer (2) from the filler opening.
3. Wash the strainer in a clean, nonflammable solvent.
4. Install the strainer into the filler opening.
5. Install the fuel tank cap.

i03957056

Fumes Disposal Filter Element - Replace

SMCS Code: 1074

i04363385

Fuel Tank Water and Sediment - Drain

SMCS Code: 1273-543

Refer to this Operation and Maintenance Manual, "Fuel Tank Shutoff and Drain Control" for the exact location of the fuel tank drain valve

Note: Refer to Operation and Maintenance Manual, "General Hazard Information" for information on containing fluid spillage.

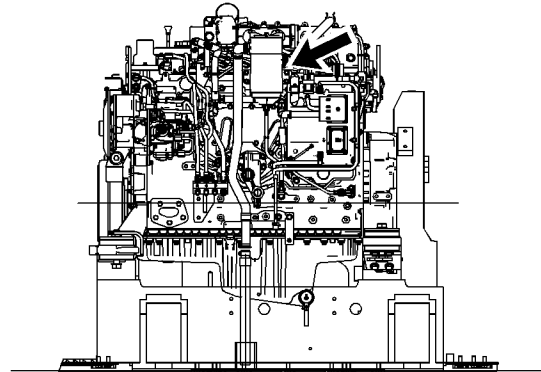

Illustration 461

g02159619

Note: Perform the maintenance while the engine is off.

1. Open the engine hood.
2. Remove the lid that holds the canister to the filter base assembly.
3. Remove the filter element. Dispose of the used element properly.
4. Install the new filter.
5. Install the lid.
6. Close the engine hood.

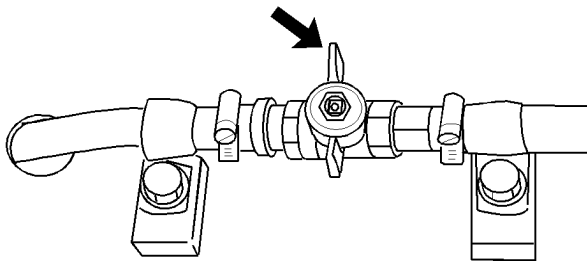

Illustration 460

g01043694

Typical example

1. Open the drain valve by turning the valve counterclockwise. Allow the water and the sediment to drain into a suitable container.

Note: Dispose of drained fluids according to local regulations.

2. Close the drain valve by turning the valve clockwise.

i06758017

Fuses - Replace

SMCS Code: 1417-510

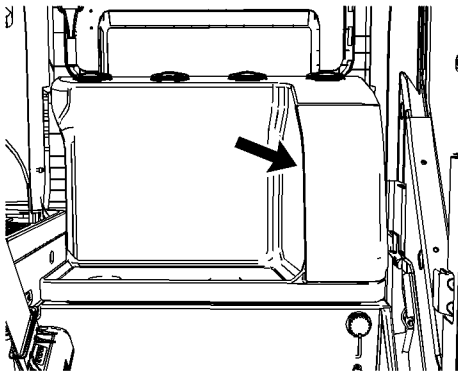

Illustration 462

g02110353

The fuse panel is located on the left side of the interior storage box. Remove the cover to access the fuses.



Fuses – Fuses protect the electrical system from damage that is caused by overloaded circuits. Change a fuse if the element separates. If the element of a new fuse separates, check the circuit and/or repair the circuit.

NOTICE

Always replace fuses with the same type and capacity fuse that was removed. Otherwise, electrical damage could result.

NOTICE

If it is necessary to replace fuses frequently, an electrical problem may exist.

Contact your Cat dealer.

To replace a fuse, use the puller that is stored in the fuse panel.

The following list identifies the circuits that are protected by each fuse. The amperage for each fuse is included with each circuit.

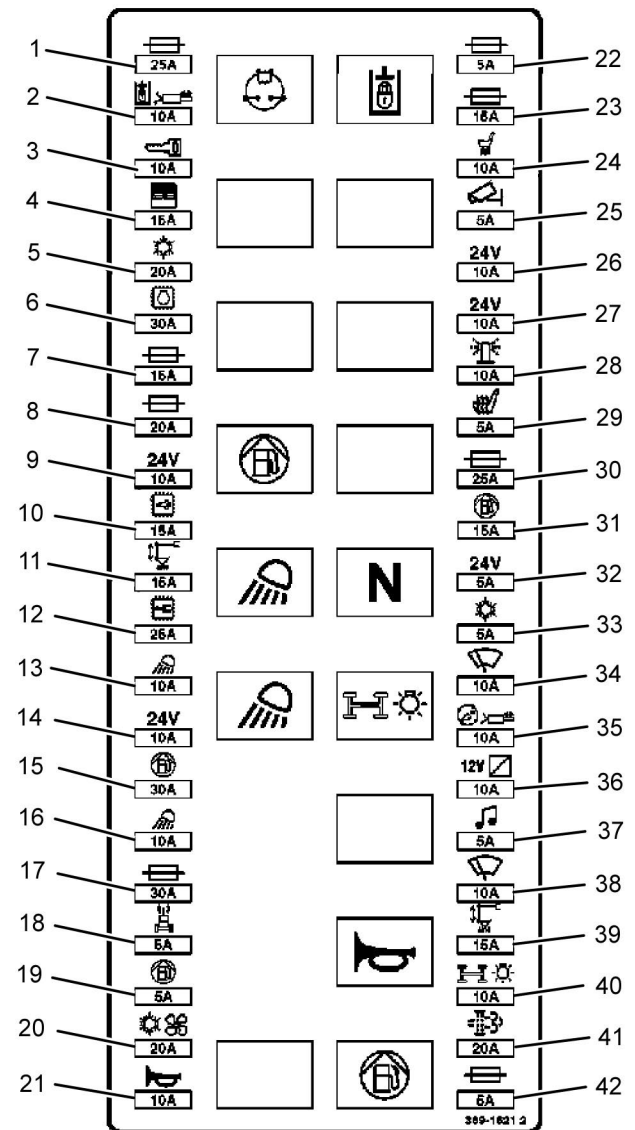

Illustration 463

g03867533

- (1) Spare – 25 Amp
- (2) Hydraulic Lock – 10 Amp
- (3) Engine Start Switch – 10 Amp
- (4) Monitor – 15 Amp
- (5) Air Conditioner Condenser Blower – 20 Amp
- (6) Engine Control Module (ECM) – 30 Amp
- (7) Spare – 15 Amp
- (8) Spare – 20 Amp
- (9) Auxiliary – 10 Amp
- (10) Engine Emission System Control Module – 15 Amp

- (11) Cat Grade Control – 15 Amp
- (12) Excavator Control Module – 25 Amp
- (13) Cab Light – 10 Amp
- (14) Auxiliary Hydraulic Circuit – 10 Amp
- (15) Electric Refueling Pump – 30 Amp
- (16) Boom Light – 10 Amp
- (17) Spare – 30 Amp
- (18) Product Link – 5 Amp
- (19) Lifting Pump – 5 Amp
- (20) Heater and Air Conditioner Blower Fan – 20 Amp
- (21) Horn – 10 Amp
- (22) Spare – 5 Amp
- (23) Spare – 15 Amp
- (24) Air Suspension Seat – 10 Amp
- (25) Camera – 5 Amp
- (26) Auxiliary – 10 Amp
- (27) Auxiliary – 10 Amp
- (28) Beacon – 10 Amp
- (29) Seat Heater – 5 Amp
- (30) Spare – 25 Amp
- (31) Priming Pump – 15 Amp
- (32) Auxiliary – 5 Amp
- (33) Air Conditioner – 5 Amp
- (34) Lower Window Wiper – 10 Amp
- (35) Attachment Solenoid – 10 Amp
- (36) 12V Converter – 10 Amp
- (37) Radio – 5 Amp
- (38) Window Wiper – 10 Amp
- (39) Cat Grade Control – 15 Amp
- (40) Chassis Light – 10 Amp
- (41) Clean Emissions Module (CEM) – 20 Amp
- (42) Spare – 5 Amp

Relays

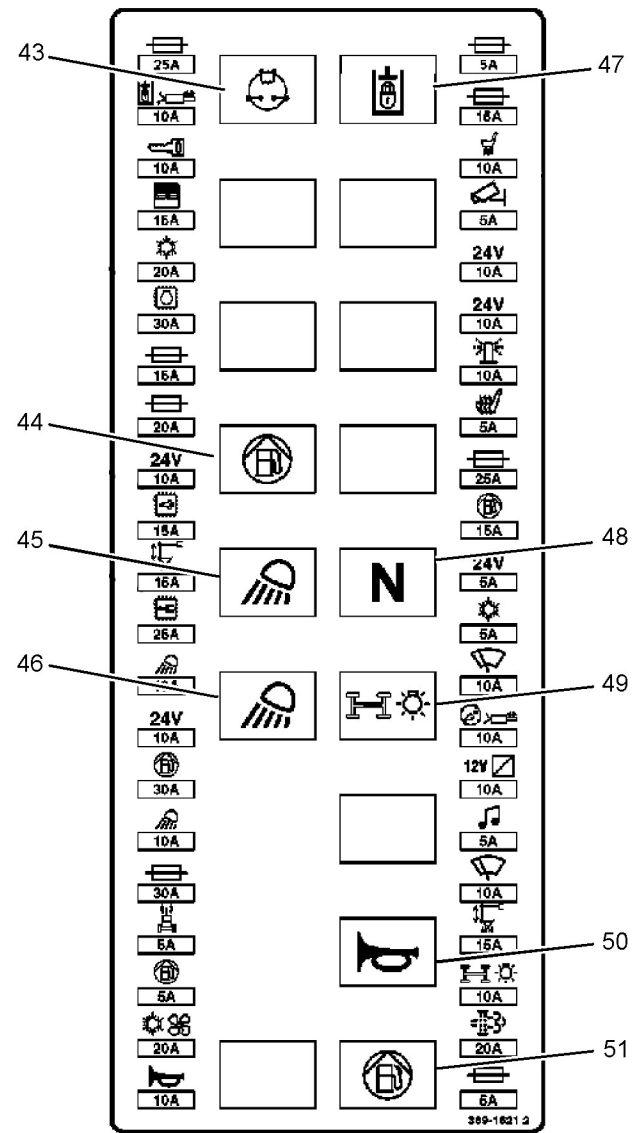

Illustration 464

g06109320

- (43) – Aftertreatment Power
- (44) – Priming Pump
- (45) – Cab Light
- (46) – Boom Light
- (47) – Hydraulic Lock
- (48) – Neutral Start
- (49) – Chassis Light

(50) – Horn**(51) – Lifting Pump**

i07349182

High Intensity Discharge Lamp (HID) - Replace (If Equipped)

SMCS Code: 1434-510

 **WARNING**

HID lamps operate at very high voltages. To avoid electrical shock and personal injury, disconnect power before servicing HID lamps.

 **WARNING**

HID bulbs become very hot during operation. Before servicing, remove power from lamp for at least five minutes to ensure lamp is cool.

NOTICE

Although HID bulb materials may change over time, HID bulbs produced at the time of the printing of this manual contain mercury. When disposing of this component, or any waste that contains mercury, please use caution and comply with any applicable laws.

1. Remove the electrical power from the high intensity discharge lamp (HID). The electrical power must be removed from the HID lamp for at least five minutes, in order to ensure that the bulb is cool.
2. Disassemble the housing for the HID lamp in order to have access to the bulb.

Note: On some HID lamps, the bulb is an integral part of the lens assembly. The bulb is not removed separately from the lens assembly. Replace the entire lens assembly on these HID lamps.

3. Remove the bulb from the HID lamp.
4. Install the replacement bulb in the HID lamp.

If the bulb is an integral part of the lens assembly, install the replacement lens assembly in the HID lamp.

Note: In order to avoid failure to the bulb that is premature, avoid touching the bulb's surface with your bare hands. Clean any fingerprints from the bulb with alcohol prior to operation.

5. Reassemble the housing for the HID lamp. Ensure that any printing on the lens is oriented correctly with respect to the HID lamp's mounting position on the machine.
6. Reattach the electrical power to the HID lamp.
7. Check the HID lamp for proper operation.

Note: Consult your Cat dealer for additional information on HID lamps.

i07108571

Hydraulic System Oil - Change

SMCS Code: 5056-044

S/N: KNE1-Up

Cat HYDO Advanced 10 Oil Change Interval

The standard Cat HYDO Advanced 10 oil change interval is every 6000 service hours or 3 years.

A 6000 service hour or 3-year maintenance interval for hydraulic oil (change) is recommended with S·O·S monitoring of the hydraulic oil after 3000 service hours. The interval for S·O·S monitoring is every 500 hours. An oil change is recommended when the oil deterioration or contamination is detected. The maintenance interval for the hydraulic oil filter is not changed.

Machines with hammers are not included in the 6000 service hour or 3-year maintenance interval. Machines with hammers must use the intervals that are listed in the Maintenance Interval Schedule. Machines that are used in severe conditions are not included in the 6000 service hour or 3-year maintenance interval. Machines that are used in severe conditions must use the interval in the Maintenance Interval Schedule.

Procedure to Change the Hydraulic Oil

 **WARNING**

Hot oil and hot components can cause personal injury. Do not allow hot oil or hot components to contact skin.

NOTICE

Care must be taken to ensure that fluids are contained during performance of inspection, maintenance, testing, adjusting, and repair of the product. Be prepared to collect the fluid with suitable containers before opening any compartment or disassembling any component containing fluids.

Refer to Special Publication, PERJ1017, "Dealer Service Tool Catalog" for tools and supplies suitable to collect and contain fluids on Cat® products.

Dispose of all fluids according to local regulations and mandates.

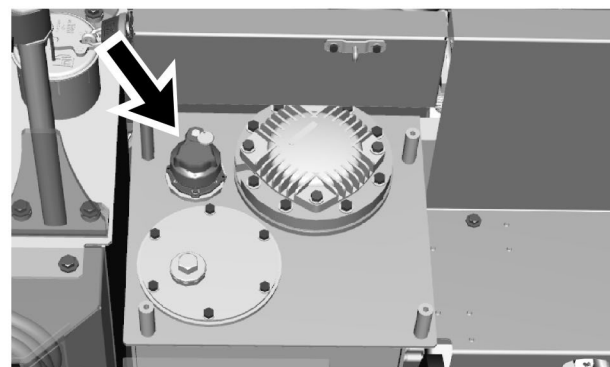

Illustration 467

g03762318

4. Clean the area thoroughly in order to keep dirt out of the screen cover. Clean the area thoroughly in order to keep dirt out of the filler cap.

⚠ WARNING

Pressurized system!

The hydraulic tank contains hot oil under pressure. To prevent burns from the sudden release of hot oil, relieve the tank pressure with the engine off by slowly turning the cap approximately 1/8 of a turn until the cap reaches the secondary stop.

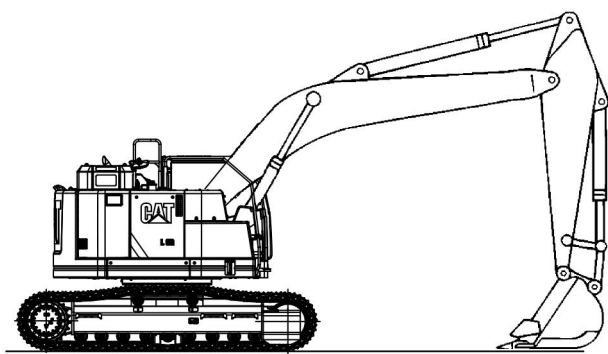

Illustration 465

g03748524

1. Park the machine on level ground. Lower the bucket to the ground so that the stick is vertical.
2. Open the engine access cover.

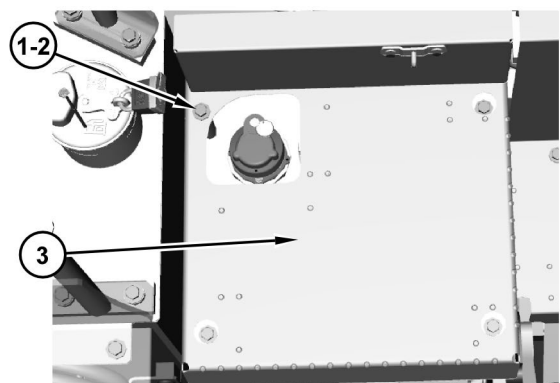

Illustration 466

g03762317

3. Remove bolts (1), washers (2), and cover (3) from the top of the hydraulic tank.

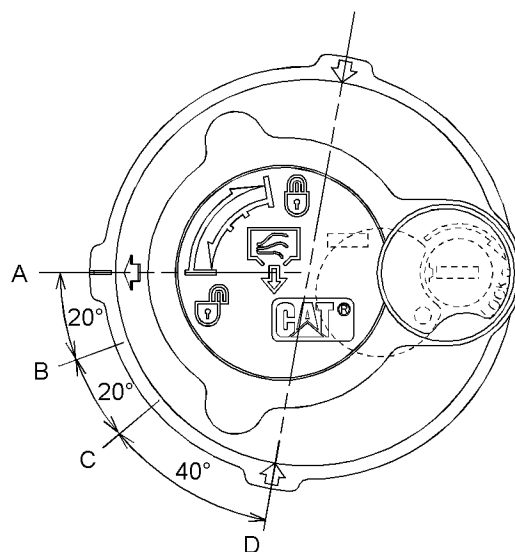

Illustration 468

g02275615

Filler cap

- (A) LOCK position
- (B) PRESSURE RELEASE - START position
- (C) PRESSURE RELEASE - END position
- (D) OPEN position

Maintenance Section
Hydraulic System Oil - Change

5. Release the pressure that may be present in the return hydraulic circuit with the following procedure. Refer to Illustration 468 for filler cap positions.
 - a. Turn the filler cap counterclockwise, with no downward force applied, and move the arrow from position (A) to position (B).
 - b. Release the pressure for a minimum of 45 seconds by moving the arrow from position (B) to position (C).
 - c. Push the center of the filler cap down. Without tilting the filler cap, move the arrow from position (C) to position (D).
 - d. The hydraulic tank pressure is relieved. Remove the filler cap.

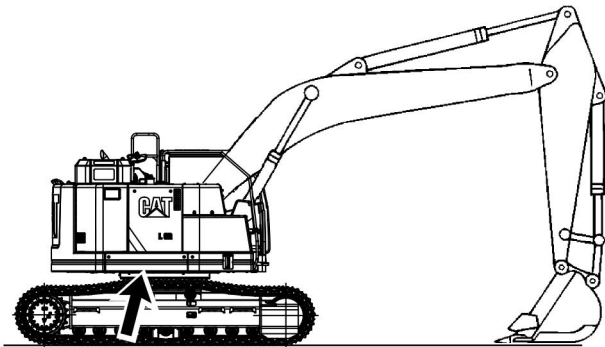

Illustration 469 g03751945

The oil drain valve is located under the hydraulic tank.

6. Remove the hydraulic tank access cover that is located under the upper structure. Removing the cover will allow access to the drain valve.

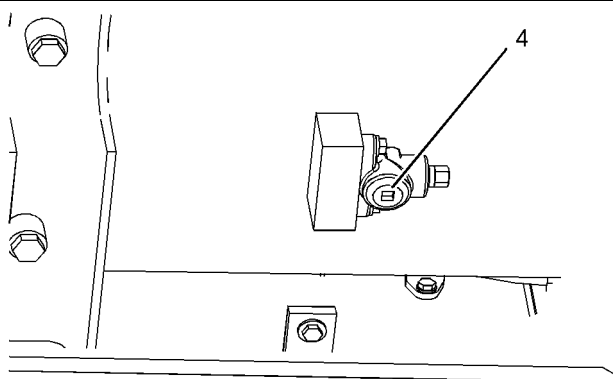

Illustration 470 g01124017

(4) Plug

Note: Refer to Operation and Maintenance Manual, "General Hazard Information" for information that pertains to containing fluid spillage.

7. Remove plug (4).
8. Inspect the O-ring. Replace the O-ring if wear or damage is evident.

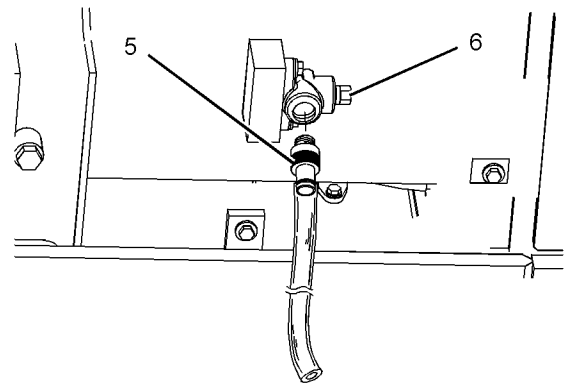

Illustration 471 g01124018

(5) Swivel hose
(6) Drain plug

9. Install swivel hose (5) with clear plastic tubing.
10. Loosen drain plug (6) in order to drain the oil.
11. Drain the oil into a suitable container.
12. After the oil has been drained, tighten drain plug (7) to 110 ± 15 N·m (81 ± 11 lb ft).
13. Remove the swivel hose.
14. Clean plug (4) and install the plug. Tighten the plug to a 75 ± 5 N·m (55 ± 3.7 lb ft).
15. Open the access door on the right side of the machine.
16. Clean the pump, the hydraulic lines, and the hydraulic tank.

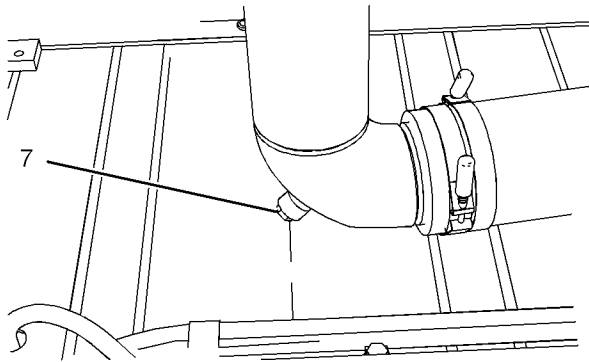

Illustration 472

g02144193

17. Remove plug (7) from the tube. Allow the oil to drain into a container.

Note: Dispose of used filters and used fluids according to local regulations.

18. Inspect the O-ring. Replace the O-ring if wear or damage is evident.

19. Clean the plug. Install the plug and the O-ring into the drain port.

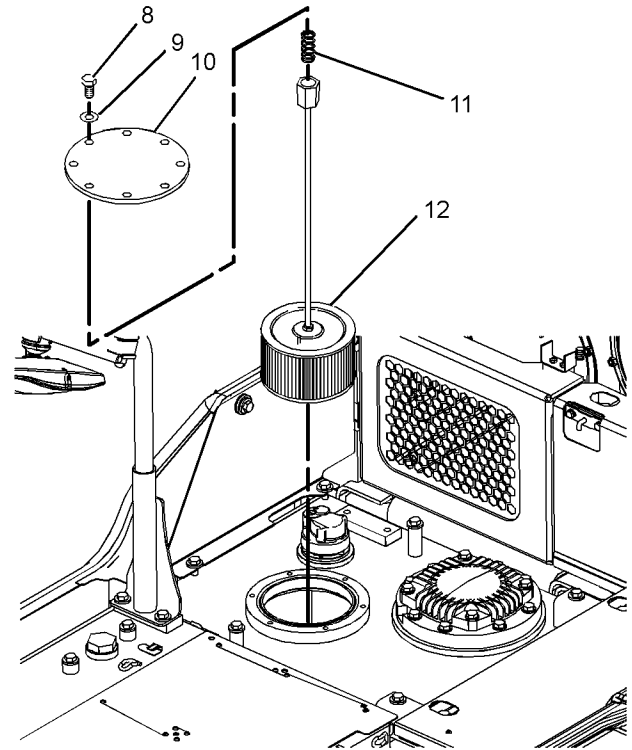

Illustration 473

g02022856

- (8) Bolts
- (9) Washers
- (10) Cover
- (11) Spring
- (12) Screen

20. Remove bolts (8), washers (9), and cover (10).

Note: Dispose of used filters and used fluids according to local regulations.

Note: Do not allow spring (11) to fall back into the tank.

21. Remove spring (11) and screen (12).

Note: Refer to Operation and Maintenance Manual, "General Hazard Information" for information on containing fluid spillage.

22. Wash the screen in a clean nonflammable solvent. Allow the screen to dry. Inspect the screen. Replace the screen, if the screen is damaged.

Maintenance Section
Hydraulic System Oil - Change

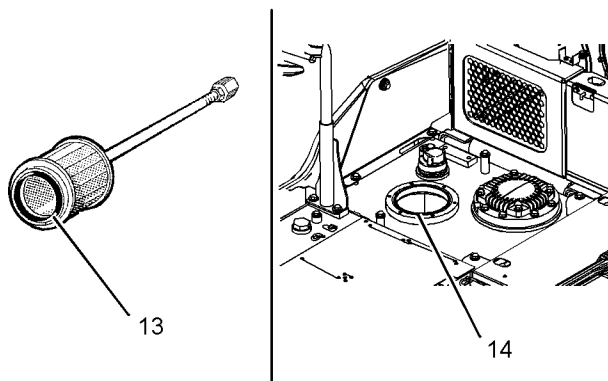

Illustration 474

g02022857

- (13) O-ring seal
(14) O-ring seal

23. Remove O-ring seal (13) from the screen.
24. Inspect O-ring seals (13) and (14). Replace the O-ring seals if wear or damage is evident.
25. Install O-ring seal (13) on screen (12).
26. Install screen (12) and spring (11). Then install cover (10), washers (9), and bolts (8).

Note: Make sure that the O-ring seals and the spring are properly positioned during installation.

27. Fill the hydraulic system oil tank. Refer to Operation and Maintenance Manual, "Capacities (Refill)".
28. Inspect the O-ring seal on the filler cap for damage. Replace the O-ring, if necessary. Clean the filler cap. Install the filler cap.

NOTICE

When the main hydraulic pump has been serviced or the hydraulic oil has been replaced, the air in the hydraulic system must be purged. Do not start the engine until the main hydraulic pump has been filled with oil.

Operating the hydraulic pump without proper lubrication will damage the pump and other hydraulic components.

29. When the hydraulic oil has been replaced, the air must be removed from the hydraulic oil system. To remove the air from the hydraulic oil system, follow Step 29a through Step 29g.

- a. Access the hydraulic pump. The hydraulic pump is located behind the right side access door.

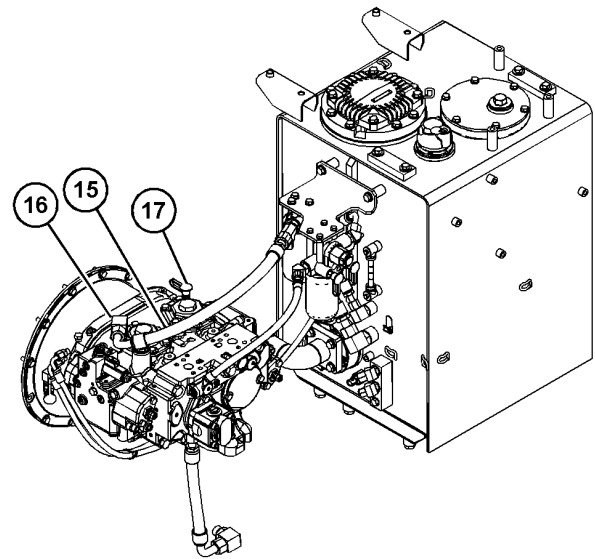

Illustration 475

g06226748

Typical example

- (15) Drain hose
(16) Connector
(17) Fitting

- b. While the engine is stopped, remove drain hose (15) and connector (16) from the top of the pump. Add hydraulic oil through the opening.

Note: Check the condition of the O-ring seals on connector (16). If the seals are damaged, replace the seals.

- c. After the pump has been filled with oil, install drain hose (15) and connector (16) to the original locations.
- d. Start the engine. When the engine is at low idle, fully raise the boom. Hold the boom in this position.
- e. Stop the engine and slowly lower the boom until the work tool is on the ground. The hydraulic tank will pressurize.
- f. Slowly loosen fitting (17) until the hydraulic oil flows out of the opening. This indicates that the air has been released from the pump.
- g. Tighten fitting (17).

30. Start the engine. Operate the engine at idling speed for 5 minutes.

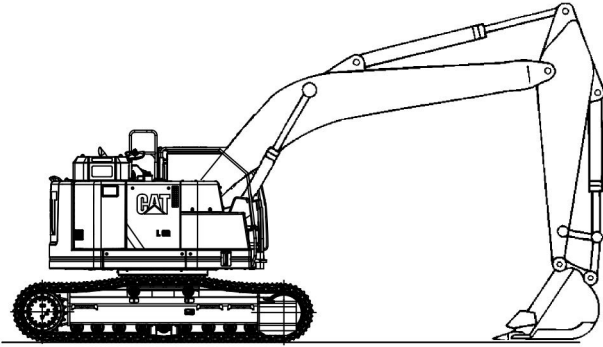

Illustration 476

g03748524

31. Operate the joysticks in order to circulate the hydraulic oil. Lower the bucket to the ground so that the stick is vertical to the ground. Stop the engine.
 32. Check the hydraulic oil level.
- Reference:** For the correct procedure, refer to Operation and Maintenance Manual, "Hydraulic System Oil Level - Check".
33. Close the access door.
 34. Close the engine hood and latch the engine hood.

i07592747

Hydraulic System Oil - Change

SMCS Code: 5056-044

S/N: SGJ1-Up

S/N: FEP1-Up

Cat HYDO Advanced Oil Change Interval

The standard Cat HYDO Advanced oil change interval is every 6000 service hours or 3 years.

A 6000 service hour or 3-year maintenance interval for hydraulic oil (change) is recommended with S·O·S monitoring of the hydraulic oil after 3000 service hours. The interval for S·O·S monitoring is every 500 hours. The Oil change is recommended when the oil deterioration or contamination is detected. The maintenance interval for the hydraulic oil filter is not changed.

Machines with hammers are not included in the 6000 service hour or 3-year maintenance interval. Machines with hammers must use the intervals that are listed in the Maintenance Interval Schedule. Machines that are used in severe conditions are not included in the 6000 service hour or 3-year maintenance interval. Machines that are used in severe conditions must use the interval in the Maintenance Interval Schedule.

Procedure to Change the Hydraulic Oil

WARNING

Hot oil and hot components can cause personal injury. Do not allow hot oil or hot components to contact skin.

NOTICE

Care must be taken to ensure that fluids are contained during performance of inspection, maintenance, testing, adjusting, and repair of the product. Be prepared to collect the fluid with suitable containers before opening any compartment or disassembling any component containing fluids.

Refer to Special Publication, PERJ1017, "Dealer Service Tool Catalog" for tools and supplies suitable to collect and contain fluids on Cat® products.

Dispose of all fluids according to local regulations and mandates.

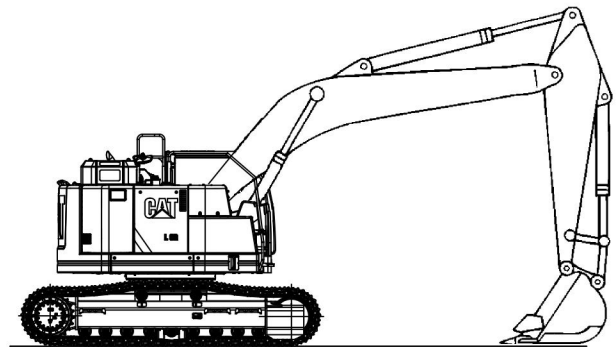

Illustration 477

g03748524

1. Park the machine on level ground. Lower the bucket to the ground so that the stick is vertical.
2. Open the engine access cover.

Maintenance Section
Hydraulic System Oil - Change

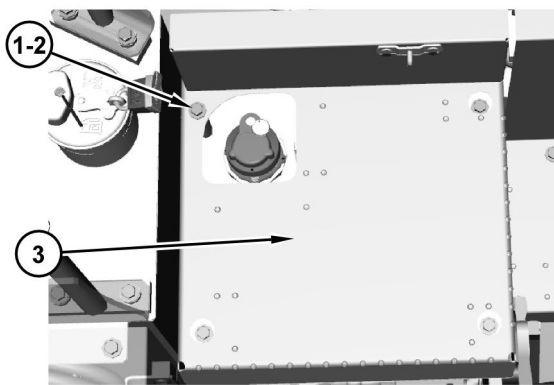

Illustration 478

g03762317

3. Remove bolts (1), washers (2), and cover (3) from the top of the hydraulic tank.

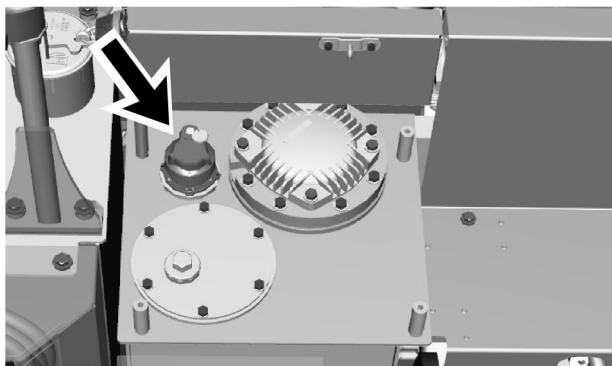

Illustration 479

g03762318

4. Clean the area thoroughly to keep dirt out of the screen cover. Clean the area thoroughly to keep dirt out of the filler cap.

⚠ WARNING

Pressurized system!

The hydraulic tank contains hot oil under pressure. To prevent burns from the sudden release of hot oil, relieve the tank pressure with the engine off by slowly turning the cap approximately 1/8 of a turn until the cap reaches the secondary stop.

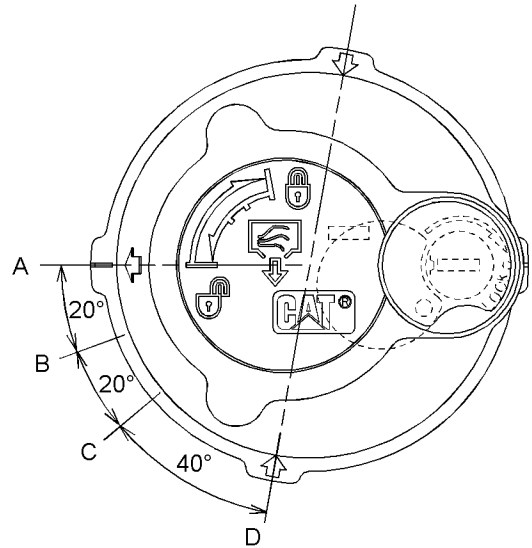

Illustration 480

g02275615

Filler cap

- (A) LOCK position
(B) PRESSURE RELEASE - START position
(C) PRESSURE RELEASE - END position
(D) OPEN position

5. Release the pressure that may be present in the return hydraulic circuit with the following procedure. Refer to Illustration 480 for filler cap positions.
- Turn the filler cap counterclockwise, with no downward force applied, and move the arrow from position (A) to position (B).
 - Release the pressure for a minimum of 45 seconds by moving the arrow from position (B) to position (C).
 - Push the center of the filler cap down. Without tilting the filler cap, move the arrow from position (C) to position (D).
 - The hydraulic tank pressure is relieved. Remove the filler cap.

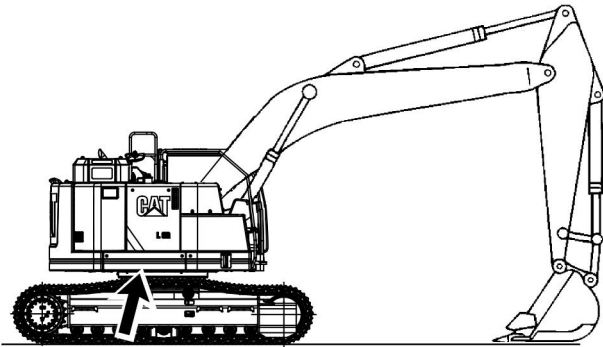

Illustration 481

g03751945

The oil drain valve is located under the hydraulic tank.

6. Remove the hydraulic tank access cover that is located under the upper structure. Removing the cover will allow access to the drain valve.

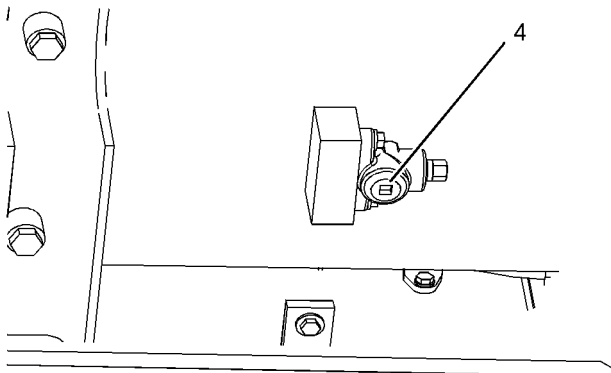

Illustration 482

g01124017

(4) Plug

Note: Refer to Operation and Maintenance Manual, "General Hazard Information" for information that pertains to containing fluid spillage.

7. Remove plug (4).
8. Inspect the O-ring. Replace the O-ring if wear or damage is evident.

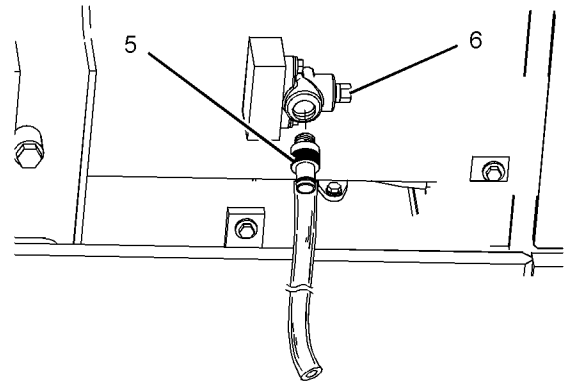

Illustration 483

g01124018

(5) Swivel hose
(6) Drain plug

9. Install swivel hose (5) with clear plastic tubing.
10. Loosen drain plug (6) to drain the oil.
11. Drain the oil into a suitable container.
12. After the oil has been drained, tighten drain plug (7) to 110 ± 15 N·m (81 ± 11 lb ft).
13. Remove the swivel hose.
14. Clean plug (4) and install the plug. Tighten the plug to a 75 ± 5 N·m (55 ± 3.7 lb ft).
15. Open the access door on the right side of the machine.
16. Clean the pump, the hydraulic lines, and the hydraulic tank.

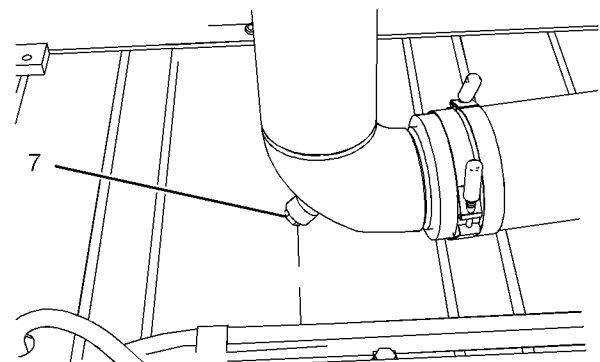

Illustration 484

g02144193

17. Remove plug (7) from the tube. Allow the oil to drain into a container.

Note: Dispose of used filters and used fluids according to local regulations.

Maintenance Section
Hydraulic System Oil - Change

18. Inspect the O-ring. Replace the O-ring if wear or damage is evident.
19. Clean the plug. Install the plug and the O-ring into the drain port.

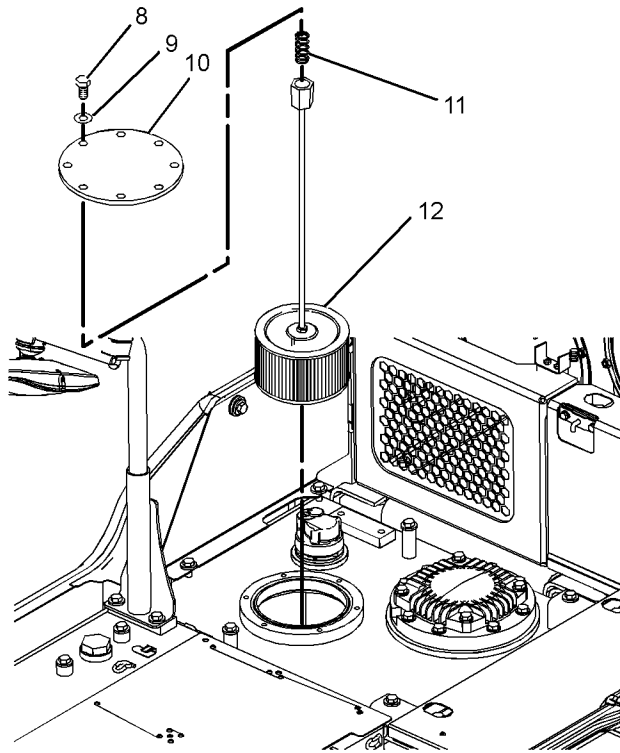

Illustration 485

g02022856

- (8) Bolts
(9) Washers
(10) Cover
(11) Spring
(12) Screen

20. Remove bolts (8), washers (9), and cover (10).

Note: Dispose of used filters and used fluids according to local regulations.

Note: Do not allow spring (11) to fall back into the tank.

21. Remove spring (11) and screen (12).

Note: Refer to Operation and Maintenance Manual, "General Hazard Information" for information on containing fluid spillage.

22. Wash the screen in a clean nonflammable solvent. Allow the screen to dry. Inspect the screen. Replace the screen, if the screen is damaged.

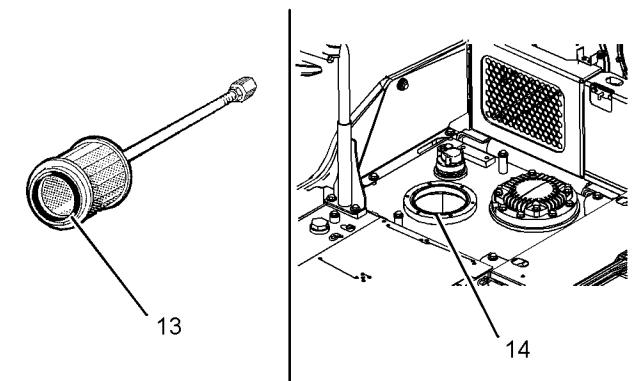

Illustration 486

g02022857

- (13) O-ring seal
(14) O-ring seal

23. Remove O-ring seal (13) from the screen.

24. Inspect O-ring seals (13) and (14). Replace the O-ring seals if wear or damage is evident.

25. Install O-ring seal (13) on screen (12).

26. Install screen (12) and spring (11). Then install cover (10), washers (9), and bolts (8).

Note: Make sure that the O-ring seals and the spring are properly positioned during installation.

27. Fill the hydraulic system oil tank. Refer to Operation and Maintenance Manual, "Capacities (Refill)".

28. Inspect the O-ring seal on the filler cap for damage. Replace the O-ring, if necessary. Clean the filler cap. Install the filler cap.

NOTICE

When the main hydraulic pump has been serviced or the hydraulic oil has been replaced, the air in the hydraulic system must be purged. Do not start the engine until the main hydraulic pump has been filled with oil.

Operating the hydraulic pump without proper lubrication will damage the pump and other hydraulic components.

29. When the hydraulic oil has been replaced, the air must be removed from the hydraulic oil system. To remove the air from the hydraulic oil system, follow Step 29a through Step 29e.

- a. Access the hydraulic pump. The hydraulic pump is located behind the right side access door.

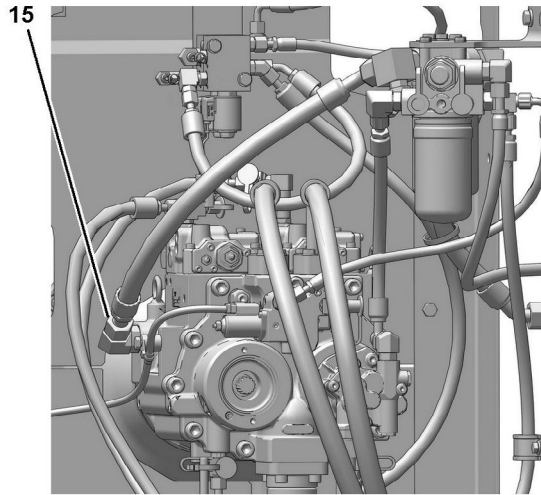

Illustration 487

g06231591

(15) Hose Coupling

- b. While the engine is stopped, loosen the hose coupling (15) on the side of the pump. Leave the hose coupling unattached for several minutes until the pump is filled with hydraulic oil. After the pump is filled with hydraulic oil, tighten the hose coupling. Start the engine. When the engine is at low idle, fully raise the boom. Hold the boom in this position.
 - c. Stop the engine. Slowly lower the boom until the bucket is on the ground. The hydraulic tank will pressurize.
 - d. Slowly loosen the hose coupling until the hydraulic oil flows out of the hose coupling. This process indicates that the air has been released from the pump. Tighten the hose coupling.
 - e. Close the access door.
- 30.** Start the engine. Operate the engine at idling speed for 5 minutes.

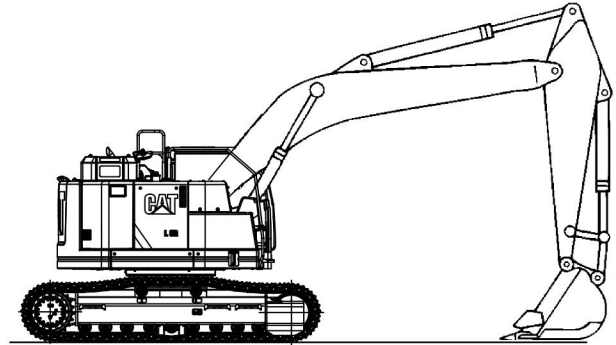

Illustration 488

g03748524

- 31.** Operate the joysticks to circulate the hydraulic oil. Lower the bucket to the ground so that the stick is vertical to the ground. Stop the engine.
 - 32.** Check the hydraulic oil level.
- Reference:** For the correct procedure, refer to Operation and Maintenance Manual, "Hydraulic System Oil Level - Check".
- 33.** Close the access door.
 - 34.** Close the engine hood and latch the engine hood.

i06004180

Hydraulic System Oil Filter (Case Drain) - Replace

SMCS Code: 5068-510; 5091-510

WARNING

Hot oil and hot components can cause personal injury. Do not allow hot oil or hot components to contact skin.

Maintenance Section
Hydraulic System Oil Filter (Case Drain) - Replace

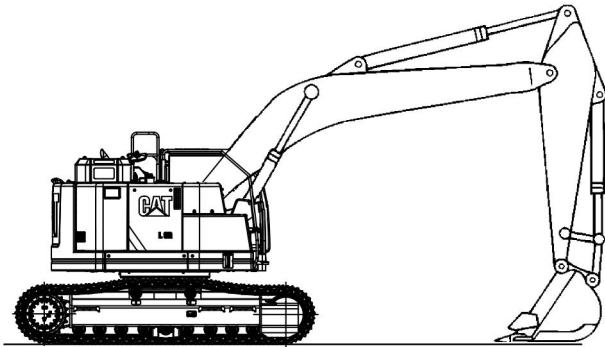

Illustration 489

g03748524

1. Park the machine on level ground. Lower the bucket to the ground so that the stick is vertical.
2. Move the hydraulic lockout control to the UNLOCKED position.
3. Turn the engine start switch to the ON position.
4. Move the joysticks and the travel levers/pedals to the full stroke positions in order to relieve the pressure in the pilot lines.
5. Turn the engine start switch to the OFF position and return the lever for the hydraulic lockout control to the LOCKED position.

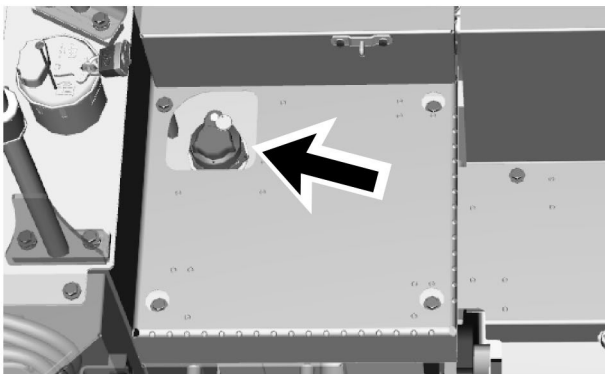

Illustration 490

g03763581

⚠ WARNING

Pressurized system!

The hydraulic tank contains hot oil under pressure. To prevent burns from the sudden release of hot oil, relieve the tank pressure with the engine off by slowly turning the cap approximately 1/8 of a turn until the cap reaches the secondary stop.

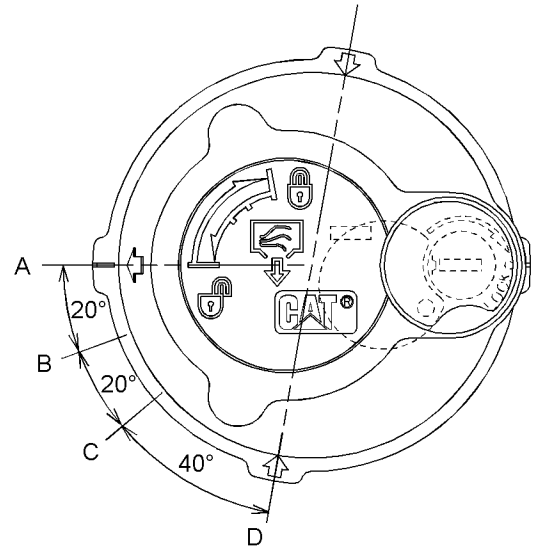

Illustration 491

g02275615

Filler cap

- (A) LOCK position
(B) PRESSURE RELEASE - START position
(C) PRESSURE RELEASE - END position
(D) OPEN position

6. Release the pressure that may be present in the return hydraulic circuit with the following procedure. Refer to Illustration 491 for filler cap positions.
 - a. Turn the filler cap counterclockwise, with no downward force applied, and move the arrow from position (A) to position (B).
 - b. Release the pressure for a minimum of 45 seconds by moving the arrow from position (B) to position (C).
 - c. Push the center of the filler cap down. Without tilting the filler cap, move the arrow from position (C) to position (D).
 - d. The hydraulic tank pressure is relieved. The filler cap can now be removed if needed.
 - e. Tighten the filler cap on the hydraulic tank to position (A).
7. After the pressure is relieved, tighten the filler cap.
8. Open the access door on the right side of the machine.

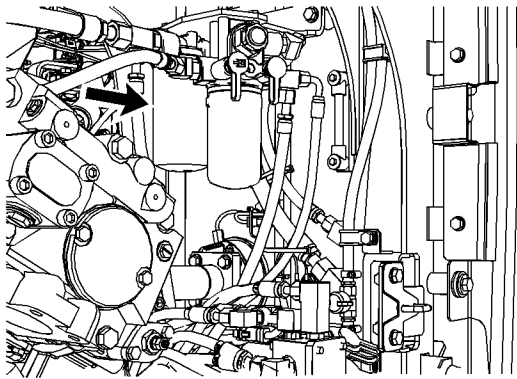

Illustration 492 g02160124
The case drain filter is located near the pilot oil filter.

9. Clean the area in order to keep dirt out of the filter base.

Note: Refer to Operation and Maintenance Manual, "General Hazard Information" for information on containing fluid spillage.

10. Remove the used case drain filter from the filter base.

Note: Used filters should always be disposed of according to local regulations.

11. Clean the filter base.

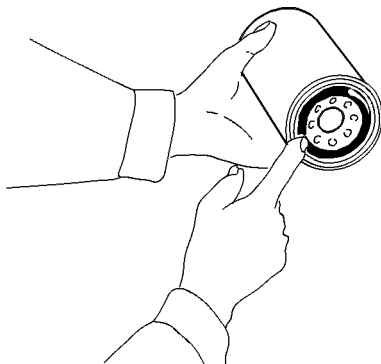

Illustration 493 g00101502

12. Coat the seal of a new case drain filter with clean hydraulic oil.

13. Install the new oil filter by hand.

Instructions for the installation of the filter are printed on the side of each Cat spin-on filter. For filters that are not Cat branded, refer to the installation instructions that are provided by the supplier of the filter.

14. Start the engine and operate the machine slowly for 10 to 15 minutes. Move each cylinder evenly through several cycles.

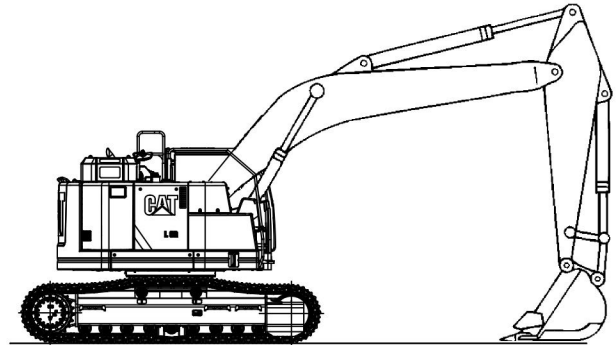

Illustration 494 g03748524

15. Return the machine to the position that is shown in Illustration 494. Check the machine for oil leaks.

16. Stop the engine.

17. Check the hydraulic oil level.

Reference: For the correct procedure, refer to Operation and Maintenance Manual, "Hydraulic System Oil Level - Check".

18. Close the access door.

i06004129

Hydraulic System Oil Filter (Pilot) - Replace

SMCS Code: 5068-510; 5068-510-PS; 5092-510

WARNING

Hot oil and hot components can cause personal injury. Do not allow hot oil or hot components to contact skin.

Maintenance Section
Hydraulic System Oil Filter (Pilot) - Replace

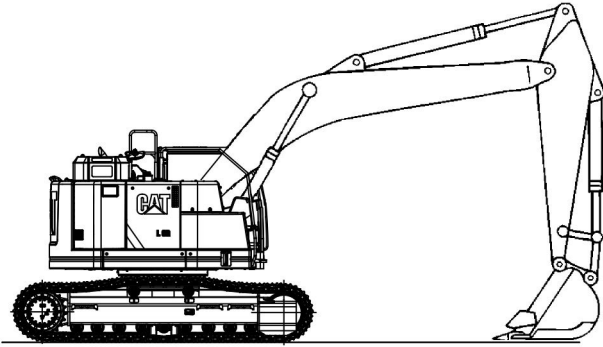

Illustration 495

g03748524

1. Park the machine on level ground. Lower the bucket to the ground so that the stick is vertical.
2. Move the hydraulic lockout control to the UNLOCKED position.
3. Turn the engine start switch to the ON position.
4. Move the joysticks and the travel levers/pedals to the full stroke positions in order to relieve the pressure in the pilot lines.
5. Turn the engine start switch to the OFF position and return the lever for the hydraulic lockout control to the LOCKED position.

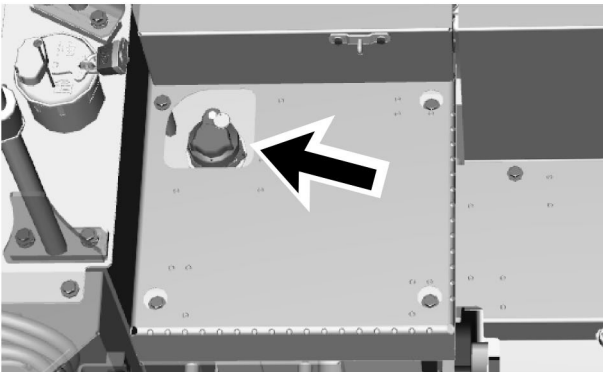

Illustration 496

g03763581

⚠ WARNING

Pressurized system!

The hydraulic tank contains hot oil under pressure. To prevent burns from the sudden release of hot oil, relieve the tank pressure with the engine off by slowly turning the cap approximately 1/8 of a turn until the cap reaches the secondary stop.

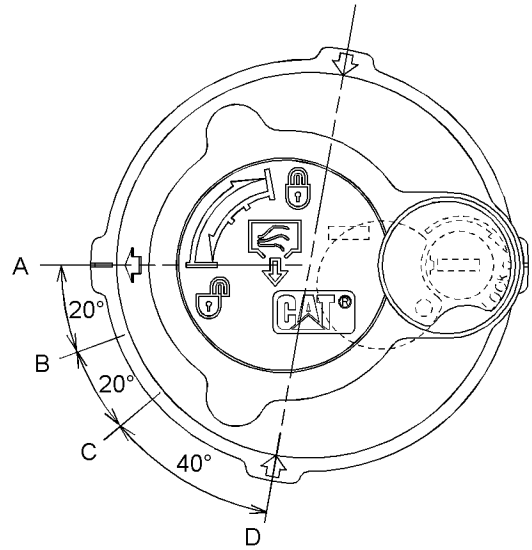

Illustration 497

g02275615

Filler cap

- (A) LOCK position
(B) PRESSURE RELEASE - START position
(C) PRESSURE RELEASE - END position
(D) OPEN position

6. Release the pressure that may be present in the return hydraulic circuit with the following procedure. Refer to Illustration 497 for filler cap positions.
 - a. Turn the filler cap counterclockwise, with no downward force applied, and move the arrow from position (A) to position (B).
 - b. Release the pressure for a minimum of 45 seconds by moving the arrow from position (B) to position (C).
 - c. Push the center of the filler cap down. Without tilting the filler cap, move the arrow from position (C) to position (D).
 - d. The hydraulic tank pressure is relieved. The filler cap can now be removed if needed.
 - e. Tighten the filler cap on the hydraulic tank to position (A).
7. Open the access door on the right side of the machine.

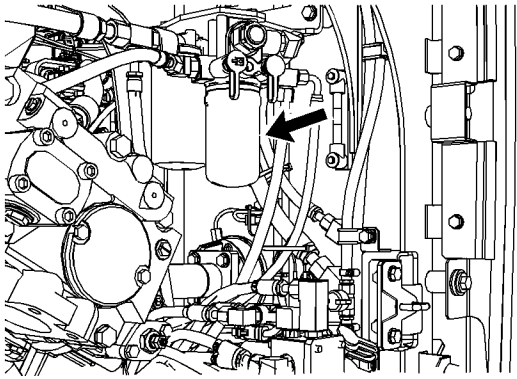

Illustration 498

g02160117

8. Clean the area in order to keep dirt out of the filter base.

Note: Refer to Operation and Maintenance Manual, "General Hazard Information" for information on containing fluid spillage.

9. Remove the used pilot filter element from the filter base.

Note: Used filters should always be disposed of according to local regulations.

10. Clean the filter base.

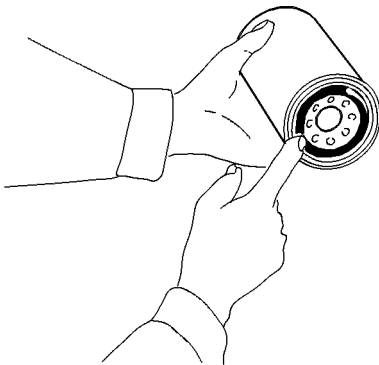

Illustration 499

g00101502

11. Coat the seal of a new pilot filter with clean hydraulic oil.

12. Install the new oil filter by hand.

Instructions for the installation of the filter are printed on the side of each Cat spin-on filter. For filters that are not Cat branded, refer to the installation instructions that are provided by the supplier of the filter.

13. Check the hydraulic oil level.

Reference: For the correct procedure, refer to Operation and Maintenance Manual, "Hydraulic System Oil Level - Check".

14. Close the access door.

i04766136

Hydraulic System Oil Filter (Return) - Replace

SMCS Code: 5068-510-RJ

WARNING

Hot oil and hot components can cause personal injury. Do not allow hot oil or hot components to contact skin.

The return filter is a cartridge type filter. The amount of foreign material that enters the hydraulic system is reduced when the filter element is replaced.

Two different filters are available for the return filter. One filter is used for standard applications such as digging and normal use of a hammer. The second filter is used for an application such as demolishing a ceiling in a tunnel with a hammer.

Note: If the message display shows that the hydraulic return filter is plugged, turn off the machine. After you make sure that the warning has disappeared, start the machine and run the machine on level ground for approximately 10 minutes. If the warning still appears in the message display, inspect the filter and replace the filter, if necessary.

Maintenance Section
Hydraulic System Oil Filter (Return) - Replace

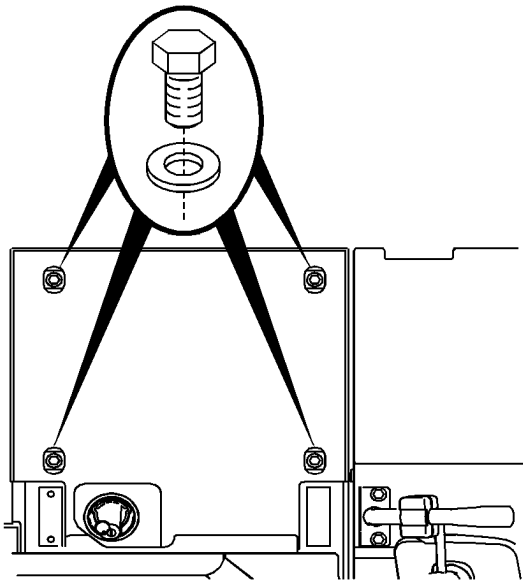

Illustration 500

g02515157

1. Remove the bolts, washers, and the cover from the top of the hydraulic tank.
2. Clean the area thoroughly in order to keep dirt out of the return filter. Clean the area thoroughly in order to keep dirt out of the filler cap.

WARNING

Pressurized system!

The hydraulic tank contains hot oil under pressure. To prevent burns from the sudden release of hot oil, relieve the tank pressure with the engine off by slowly turning the cap approximately 1/8 of a turn until the cap reaches the secondary stop.

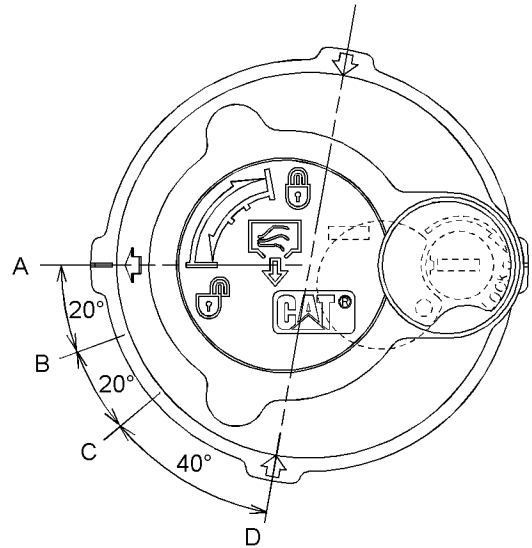

Illustration 501

g02275615

Filler cap

- (A) LOCK position
(B) PRESSURE RELEASE - START position
(C) PRESSURE RELEASE - END position
(D) OPEN position

3. Release the pressure that may be present in the return hydraulic circuit with the following procedure. Refer to Illustration 501 for filler cap positions.
 - a. Turn the filler cap counterclockwise, with no downward force applied, and move the arrow from position (A) to position (B).
 - b. Release the pressure for a minimum of 45 seconds by moving the arrow from position (B) to position (C).
 - c. Push the center of the filler cap down. Without tilting the filler cap, move the arrow from position (C) to position (D).
 - d. The hydraulic tank pressure is relieved. The filler cap can now be removed if needed.
 - e. Tighten the filler cap on the hydraulic tank to position (A).
4. Check the hydraulic system oil level.

Reference: For the correct procedure, refer to Operation and Maintenance Manual, "Hydraulic System Oil Level - Check".

5. Remove the filter cartridge. Perform the following steps in order to remove the filter cartridge.

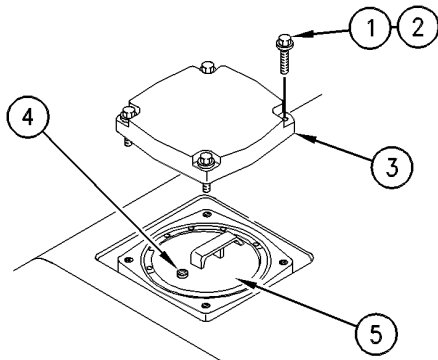

Illustration 502

g00102211

- (1) Bolts
- (2) Washers
- (3) Cover
- (4) Plug
- (5) Filter cartridge

a. Remove bolts (1), washers (2), and cover (3).

Note: Refer to Operation and Maintenance Manual, "General Hazard Information" for information on containing fluid spillage.

b. Remove plug (4) in order to release the pressure in filter cartridge (5).

Note: When plug (4) is removed the oil level in the return filter drops to the level of the hydraulic tank.

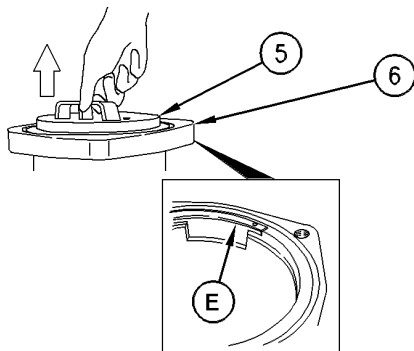

Illustration 503

g02515262

- (5) Filter cartridge
- (6) Filter case
- (E) Guide

c. Pull up the handle at the top of filter cartridge (5) until the filter cartridge contacts guide (E) on filter case (6).

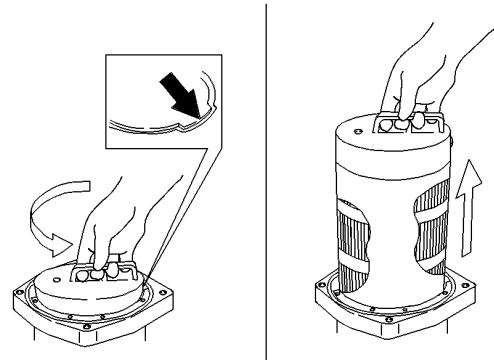

Illustration 504

g00102214

d. Turn the filter cartridge counterclockwise by 180 degrees in order to align the projection of the filter cartridge with the notch of the filter case. Pull out the filter cartridge.

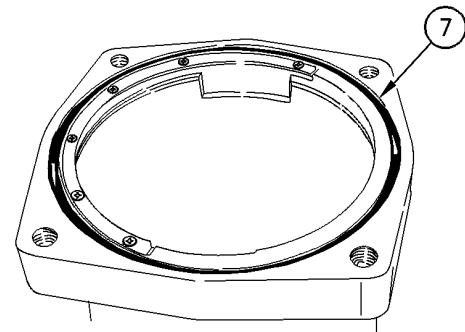

Illustration 505

g00102219

(7) O-ring

e. Inspect the cover and O-ring (7). If either part is damaged, replace the part.

f. Inspect the filter cartridge for debris and for damage. If necessary, replace the filter cartridge.

6. Remove the filter element. Perform Step 6a through Step 6f in order to remove the filter element.

Maintenance Section
Hydraulic System Oil Filter (Return) - Replace

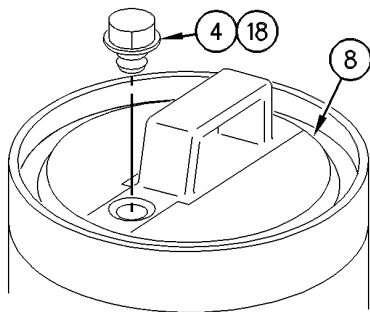

Illustration 506

g00104507

- (4) Plug
- (8) Plate
- (18) O-ring

a. Make sure that plug (4) is removed. Make sure that all of O-ring (18) is removed from plate (8).

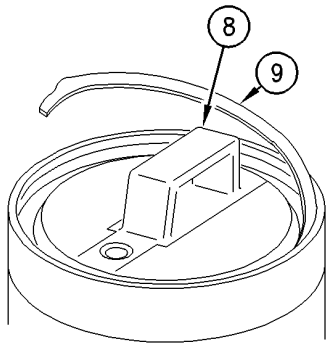

Illustration 507

g00918893

- (8) Plate
- (9) Spiral retaining ring

b. Remove spiral retaining ring (9).

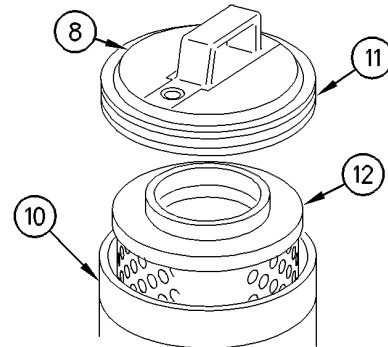

Illustration 508

g00104510

- (8) Plate
- (10) Shell
- (11) O-ring
- (12) Filter element

c. Hold the filter cartridge with one hand. Grasp the grip of plate (8) with your other hand. Lift plate (8) in order to separate plate (8) from the filter cartridge.

d. Remove O-ring (11) from plate (8).

e. Lift filter element (12) from shell (10).

f. Pour the remaining oil into a suitable container.

Note: Dispose of used oil according to local regulations.

g. Repeat Step 6a through Step 6f for the other filter groups.

7. Clean the shell of the filter cartridge. Perform Step 7a through Step 7d in order to clean the shell of the filter cartridge.

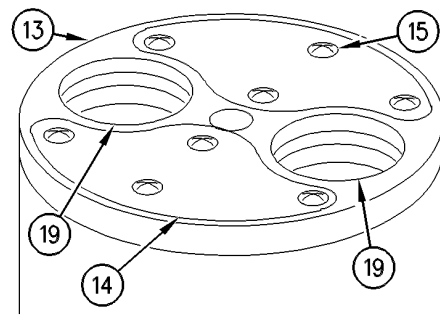

Illustration 509

g00104511

- (13) Slide plate
- (14) Pads
- (15) Screws
- (19) Port

a. Turn shell (10) upside-down.

- b. Remove screws (15).
- c. Remove Pads (14) from slide plate (13).
- d. Wash the following parts in a clean nonflammable solvent: plug (4), plate (8), spiral retaining ring (9), shell (10) and Pads (14). Dry the parts.

8. Install the filter elements. Perform Step 8a through Step 8k in order to install the filter elements.

Note: Consult a Caterpillar dealer for the Service Kit that is needed to install the filter element and the filter cartridge.

- a. Apply spray type oil to the inside of shell (10) in order to prevent rust.
- b. Apply grease to a new O-ring (11).
- c. Plate (8) will contact the inside of shell (10). Apply grease to this point.
- d. Apply grease to O-rings inside ports (19) at the bottom of shell (10).
- e. Install new Pads (14). Tighten the screws to a torque of 0.4 N·m (3.5 lb in).
- f. Apply spray type oil into the clearance between shell (10) and slide plate (13).

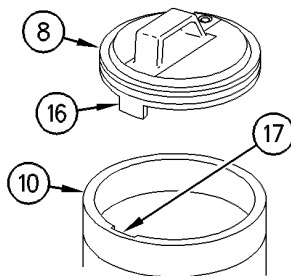

Illustration 510

g00104512

- (8) Plate
- (10) Shell
- (16) Boss
- (17) Notch

- g. Turn over shell (10). Apply grease to the two O-rings on new element (12). Install element (12) into shell (10).
- h. Move boss (16) in alignment with notch (17). Install plate (8) into shell (10).
- i. Install spiral retaining ring (9) into the groove in shell (10).

- j. Apply grease to new O-ring (18). Install O-ring (18) on plug (4).

k. Install plug (4) into plate (8).

9. Install the filter cartridge. Perform Step 9a through Step 9e in order to install the filter cartridge.

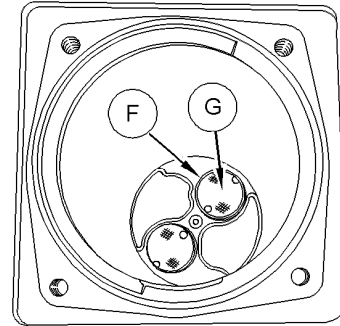

Illustration 511

g02515259

- (F) Port
- (G) Slide plate

- a. Check that ports (F) at the bottom of the filter case are closed.

Note: If the ports are open, rotate slide plate (G) counterclockwise to the stopper in order to fully close the ports. When the ports are fully closed, any remaining oil in the filter case should be completely removed.

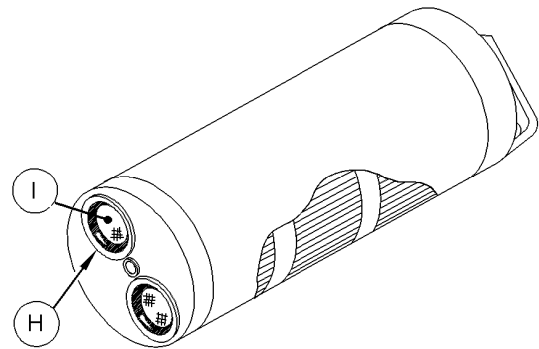

Illustration 512

g02515258

- (I) Slide plate
- (H) Port

- b. Check that ports (H) of the filter cartridge are fully closed.

Note: The filter cartridge cannot be installed unless the ports are fully closed. If the ports are open, rotate slide plate (I) counterclockwise to the stopper in order to fully close the ports.

i05970178

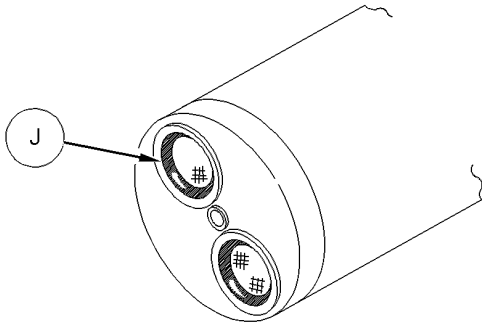

Illustration 513 g02515257
(J) O-rings

- c. Check that O-rings (J) have been installed and that oil has been applied to O-rings (J).

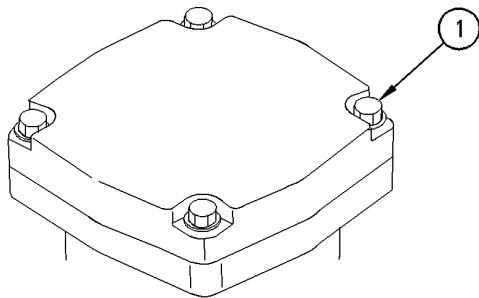

Illustration 514 g00102225
(1) Bolts

- d. Install the filter cartridge into the filter case. Turn the filter cartridge clockwise by 180 degrees and push down the filter cartridge when the filter cartridge contacts guide (E).
- e. Install plug (4), cover (3), washers (2), and bolts (1). Tighten bolts (1) to a torque of 29 ± 5 N·m (22 ± 4 lb ft).

10. Check the hydraulic system oil level.

Reference: For the correct procedure, refer to Operation and Maintenance Manual, "Hydraulic System Oil Level - Check".

Hydraulic System Oil Level - Check

SMCS Code: 5050-535

WARNING

Hot oil and hot components can cause personal injury. Do not allow hot oil or hot components to contact skin.

NOTICE

Never remove the fill/vent plug from the hydraulic tank if the oil is hot.

Air can enter the system and cause pump damage.

Note: In addition to an oil level gauge, your machine may be equipped with an automated function for checking fluid levels. Refer to Operation and Maintenance Manual, "Monitoring System" regarding the automated system.

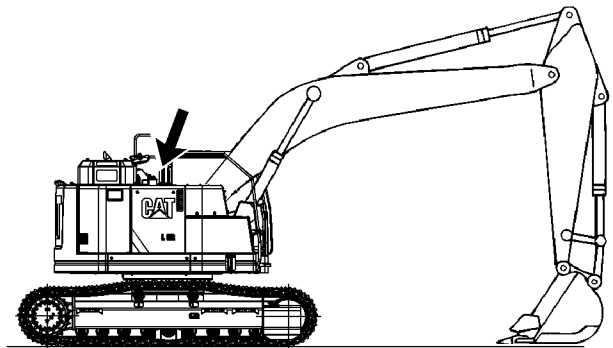

Illustration 515 g03742779

The hydraulic oil tank is on the right side of the machine.

1. Park the machine on level ground. Lower the bucket to the ground with the stick in a vertical position, as shown.
2. Open the access door on the right side of the machine.

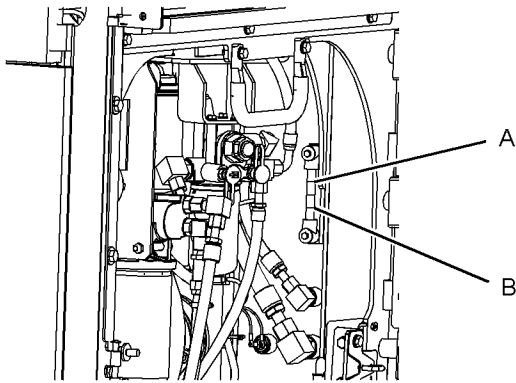

Illustration 516 g02024082

(A) High temperature range
(B) Low temperature range

3. For a cold machine, maintain the hydraulic oil level in the low temperature range (B). For a machine that is at normal operating temperature, maintain the hydraulic oil level in the high temperature range (A).

4. Close the access door.

Note: Perform Step 5 through Step 8 if the oil level is low.

Note: Refer to Operation and Maintenance Manual, "General Hazard Information" for information that pertains to Containing Fluid Spillage.

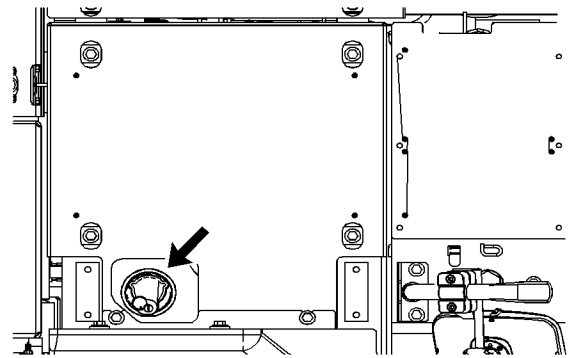

Illustration 517 g02024028

⚠ WARNING

Pressurized system!

The hydraulic tank contains hot oil under pressure. To prevent burns from the sudden release of hot oil, relieve the tank pressure with the engine off by slowly turning the cap approximately 1/8 of a turn until the cap reaches the secondary stop.

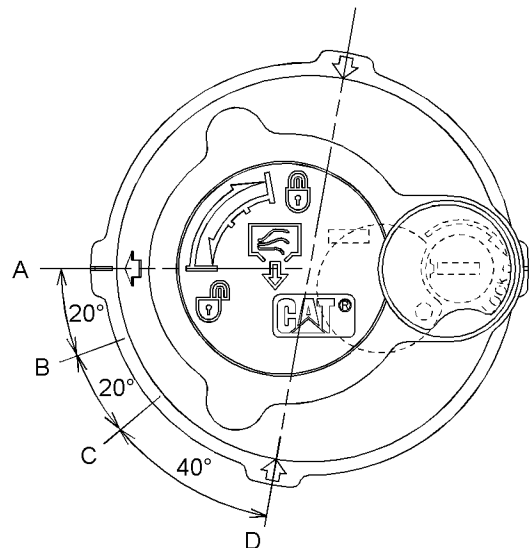

Illustration 518 g02275615

Filler cap

(A) LOCK position
(B) PRESSURE RELEASE - START position
(C) PRESSURE RELEASE - END position
(D) OPEN position

5. Release the pressure that may be present in the return hydraulic circuit with the following procedure. Refer to Illustration 518 for filler cap positions.

Maintenance Section
Hydraulic System Oil Sample - Obtain

- a. Turn the filler cap counterclockwise, with no downward force applied, and move the arrow from position (A) to position (B).
 - b. Release the pressure for a minimum of 45 seconds by moving the arrow from position (B) to position (C).
 - c. Push the center of the filler cap down. Without tilting the filler cap, move the arrow from position (C) to position (D).
 - d. The hydraulic tank pressure is relieved. Remove the filler cap.
6. Add oil if necessary. See Operation and Maintenance, "Lubricant Viscosities"
 7. Check the O-ring seal of the filler cap. Replace the O-ring seal if the O-ring seal is damaged.
 8. Clean the filler cap. Tighten the filler cap on the hydraulic tank to position (A).

i05966675

Hydraulic System Oil Sample - Obtain

SMCS Code: 5050-008-OC; 5095-008; 5095-SM; 7542; 7542-008

Note: If Cat HYDO Advanced hydraulic oils are used, the hydraulic oil change interval is extended to 6000 hours. S·O·S services after 3,000 hour is strongly Recommended. Consult your Cat dealer for details.

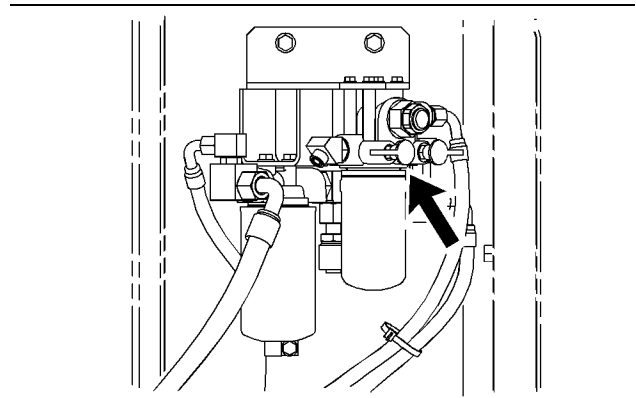

Illustration 519

g01345563

The hydraulic oil sampling valve is near the pilot filter. Obtain a sample of the hydraulic oil from the hydraulic oil sampling valve that is located on the hydraulic oil filter housing. Refer to Special Publication, SEBU6250, "S·O·S Oil Analysis" for information that pertains to obtaining a sample of the hydraulic oil. Refer to Special Publication, PEGJ0047, "How To Take A Good Oil Sample" for more information about obtaining a sample of the hydraulic oil.

i03753191

Indicators and Gauges - Test

SMCS Code: 7450-081; 7490-081

1. Look for broken lenses on the gauges, broken indicator lights, broken switches, and other broken components in the cab.
2. Start the engine.
3. Look for inoperative gauges.
4. Turn on all machine lights. Check for proper operation.
5. Move the machine forward. Release the travel levers and the travel pedals. The machine should stop.
6. Stop the engine.
7. Make any repairs that are required before operating the machine.

i07051364

Oil Filter (Hydraulic Hammer) - Replace

SMCS Code: 5068-510

WARNING

Hot oil and hot components can cause personal injury. Do not allow hot oil or hot components to contact skin.

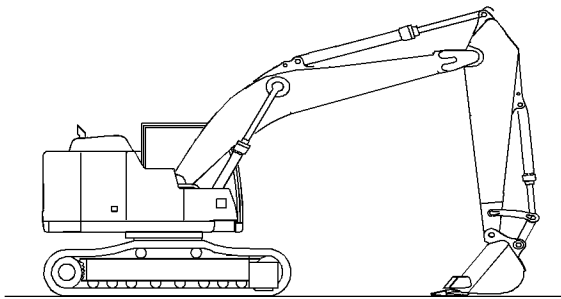

Illustration 520

g02419476

1. Park the machine on level ground in the service position as shown.
2. Move the hydraulic lockout control to the UNLOCKED position.
3. Turn the engine start switch to the ON position.
4. Move the joysticks and the travel levers/pedals to the full stroke positions to relieve the pressure in the hydraulic lines.
5. Turn the engine start switch to the OFF position and return the lever for the hydraulic lockout control to the LOCKED position.

WARNING

Pressurized system!

The hydraulic tank contains hot oil under pressure. To prevent burns from the sudden release of hot oil, relieve the tank pressure with the engine off by slowly turning the cap approximately 1/8 of a turn until the cap reaches the secondary stop.

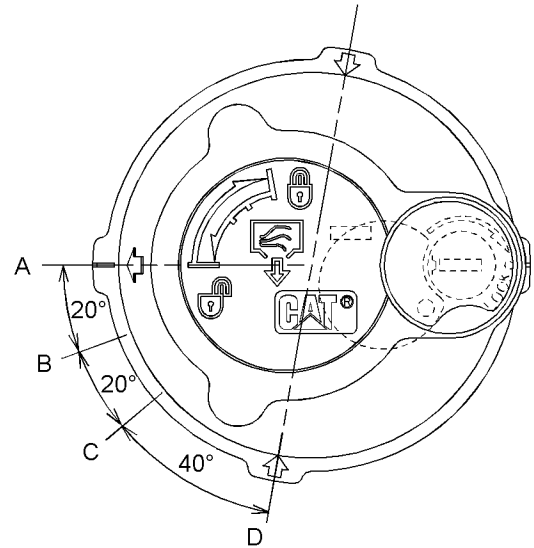

Illustration 521

g02275615

Filler cap

- (A) LOCK position
- (B) PRESSURE RELEASE - START position
- (C) PRESSURE RELEASE - END position
- (D) OPEN position

6. Release the pressure that may be present in the return hydraulic circuit with the following procedure. Refer to Illustration 521 for filler cap positions.
 - a. Turn the filler cap counterclockwise, with no downward force applied, and move the arrow from position (A) to position (B).
 - b. Release the pressure for a minimum of 45 seconds by moving the arrow from position (B) to position (C).
 - c. Push the center of the filler cap down. Without tilting the filler cap, move the arrow from position (C) to position (D).
 - d. The hydraulic tank pressure is relieved. Tighten the filler cap on the hydraulic tank to position (A).
7. The oil filter for the hammer is located near the base of the boom.

Note: Some configurations may invert the hammer filter installation.

Maintenance Section
Oil Filter (Hydraulic Hammer) - Replace

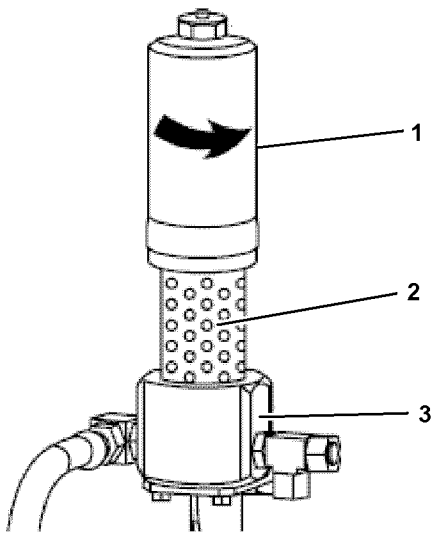

Illustration 522

g02902799

- (1) Filter case
- (2) Filter element
- (3) Filter base

8. Position a suitable container to contain the oil.

Note: Refer to Operation and Maintenance Manual, "General Hazard Information" for information on containing fluid spillage.

9. Loosen filter case (1).

10. Lift filter case (1) to remove filter element (2).

11. Remove the used filter element from filter base (3).

Note: The element cannot be reused.

Note: Used filter elements should always be disposed of according to local regulations.

12. Clean filter case (1) and inspect the O-ring for damage. Replace the O-ring if necessary.

13. Install the new filter element.

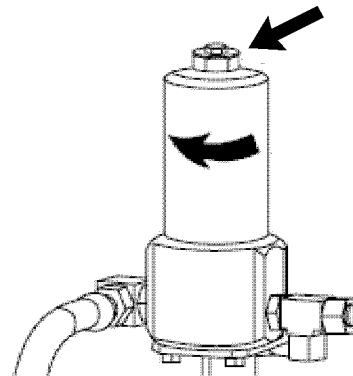

Illustration 523

g02909599

14. Assemble filter case (1). Tighten the nut on the filter case to a torque of $100 \pm 10 \text{ N}\cdot\text{m}$ ($74 \pm 7 \text{ lb ft}$).

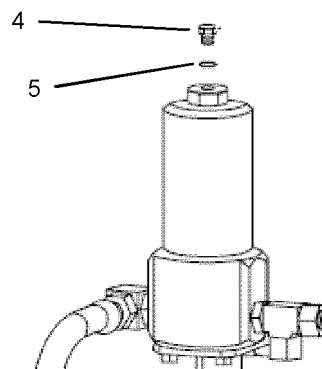

Illustration 524

g02909737

15. Remove plug (4) and inspect O-ring (5) for damage. Replace the O-ring if necessary. Tighten plug (4) to a torque of $60 \pm 5 \text{ N}\cdot\text{m}$ ($44 \pm 3.5 \text{ lb ft}$)

16. Start the engine and operate the machine slowly for 10 to 15 minutes. Move each cylinder evenly through several cycles and operate the hammer.

17. Return the machine to the service position. Check the machine for oil leaks.

18. Stop the engine.

19. Check the hydraulic oil level.

Reference: For the correct procedure, refer to Operation and Maintenance Manual, "Hydraulic System Oil Level - Check".

i05254495

i05805860

Radiator, Aftercooler and Oil Cooler Cores - Clean

SMCS Code: 1063-070-KO; 1353-070-KO; 1374-070-KO

1. Open the engine hood.
2. Open the rear access door on the left side of the machine.

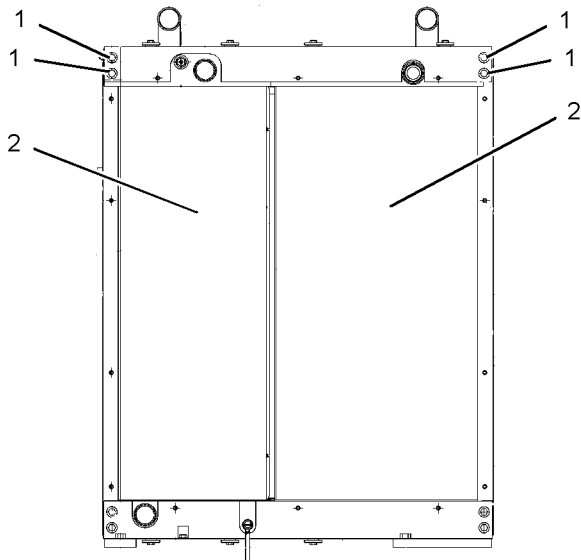

Illustration 525

g03346364

3. Remove four pins (1).
4. Remove screens (2)
5. Check all of the core fins for debris.
6. Remove dust and debris from all of the core fins and from the screens.

Compressed air is preferred, but high-pressure water or steam can be used to remove dust and general debris from a core.

See Special Publication, SEBD0518, "Know Your Cooling System" for more detailed information about cleaning core fins.

7. Install screens (2) with bolts (1).
8. Close the rear access door on the left side of the machine.
9. Close the engine hood.

Receiver Dryer (Refrigerant) - Replace

SMCS Code: 7322-510; 7322-710

WARNING

Personal injury can result from contact with refrigerant.

Contact with refrigerant can cause frost bite. Keep face and hands away to help prevent injury.

Protective goggles must always be worn when refrigerant lines are opened, even if the gauges indicate the system is empty of refrigerant.

Always use precaution when a fitting is removed. Slowly loosen the fitting. If the system is still under pressure, release it slowly in a well ventilated area.

Personal injury or death can result from inhaling refrigerant through a lit cigarette.

Inhaling air conditioner refrigerant gas through a lit cigarette or other smoking method or inhaling fumes released from a flame contacting air conditioner refrigerant gas, can cause bodily harm or death.

Do not smoke when servicing air conditioners or wherever refrigerant gas may be present.

Use a certified recovery and recycling cart to properly remove the refrigerant from the air conditioning system.

NOTICE

If the refrigerant system has been open to the outside air (without being plugged) for more than 30 minutes, the receiver-dryer must be replaced. Moisture will enter an open refrigerant system and cause corrosion which will lead to component failure.

Refer to Service Manual, "Air Conditioning and Heating R-134a for All Caterpillar Machines" for the proper procedure to change the receiver-dryer assembly and for the procedure to reclaim the refrigerant gas.

i05252968

Rollover Protective Structure (ROPS) - Inspect

SMCS Code: 7323-040; 7325-040

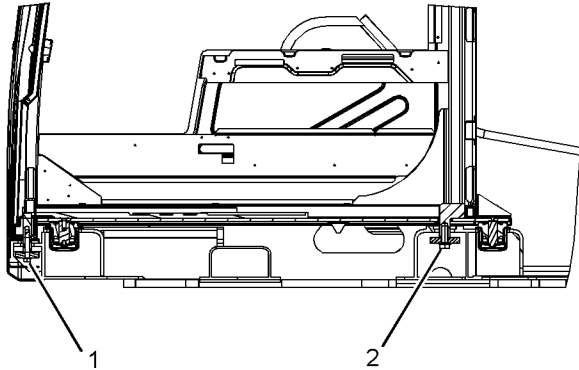

Illustration 526

g02008734

Inspect the ROPS for loose bolts or for damaged bolts. Replace any damaged bolts or missing bolts with original equipment parts only.

- Tighten the M16 bolt (1) to 125 ± 20 N·m (92 ± 15 lb ft).
- Tighten the M24 bolt (2) to 425 ± 50 N·m (315 ± 40 lb ft).

Do not straighten the ROPS. Do not repair the ROPS by welding reinforcement plates to the ROPS.

Consult your Cat dealer for inspection of any potential damage or repair of any damage to any operator protective structure. (Including ROPS, FOPS, TOPS, OPS, and OPG) Refer to Special Instruction, SEHS6929, "Inspection, Maintenance, and Repair of Operator Protective Structures (OPS) and Attachment Installation Guidelines for All Earthmoving Machinery"

i04423622

Seat Belt - Inspect

SMCS Code: 7327-040

Always inspect the condition of the seat belt and the condition of the seat belt mounting hardware before you operate the machine. Replace any parts that are damaged or worn before you operate the machine.

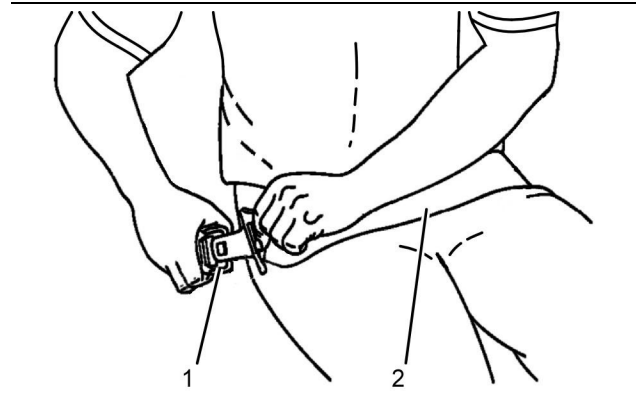

Illustration 527

g02620101

Typical example

Inspect buckle (1) for wear or for damage. If the buckle is worn or damaged, replace the seat belt.

Inspect seat belt (2) for webbing that is worn or frayed. Replace the seat belt if the webbing is worn or frayed.

Inspect all seat belt mounting hardware for wear or for damage. Replace any mounting hardware that is worn or damaged. Make sure that the mounting bolts are tight.

If your machine is equipped with a seat belt extension, also perform this inspection procedure for the seat belt extension.

Contact your Cat dealer for the replacement of the seat belt and the mounting hardware.

Note: The seat belt should be replaced within 3 years of the date of installation. A date of installation label is attached to the seat belt retractor and buckle. If the date of installation label is missing, replace belt within 3 years from the year of manufacture as indicated on belt webbing label, buckle housing, or installation tags (non-retractable belts).

i02012090

Seat Belt - Replace

SMCS Code: 7327-510

Within three years of the date of installation (2) or within five years of the date of manufacture (1), replace the seat belt. Replace the seat belt at the date which occurs first. A date label for determining the age of the seat belt is attached to each seat belt.

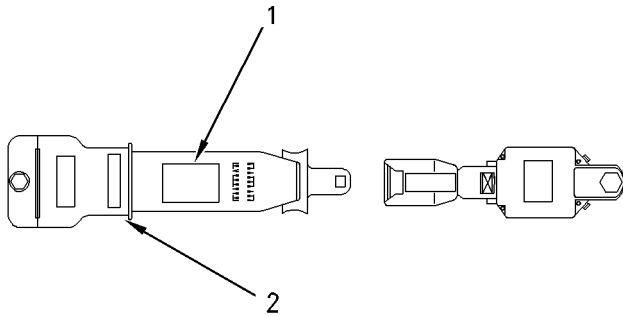

Illustration 528

g00951532

- (1) Date of Manufacture
(2) Date of Installation

Contact your Caterpillar dealer for the replacement of the seat belt.

i05978417

Swing Bearing - Lubricate

SMCS Code: 7063-086

Note: Refer to Operation and Maintenance Manual, "Lubricant Viscosities" for more information on the types of grease to use.

Note: Refer to Special Publication, SEBU6250, "Caterpillar Machine Fluids Recommendations" for more information on grease.

Wipe the fittings before you lubricate the swing bearing.

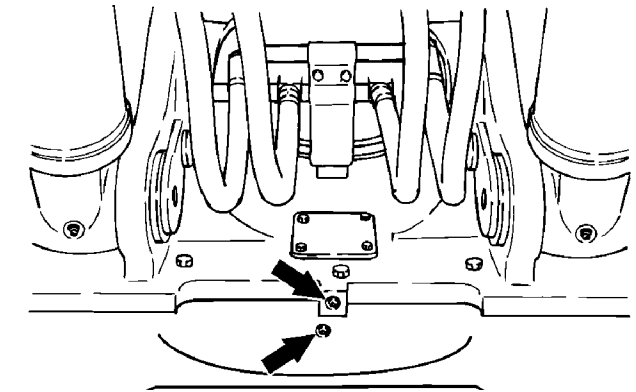

Illustration 530

g00752615

Apply lubricant through the fittings until the lubricant overflows the bearing seals.

i03966033

Swing Drive Oil - Change

SMCS Code: 5459-044

WARNING

Hot oil and hot components can cause personal injury. Do not allow hot oil or hot components to contact skin.

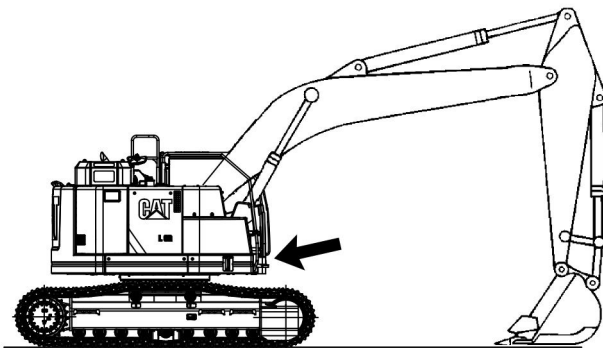

Illustration 529

g03745283

The swing bearing is under the base of the boom.

Maintenance Section
Swing Drive Oil - Change

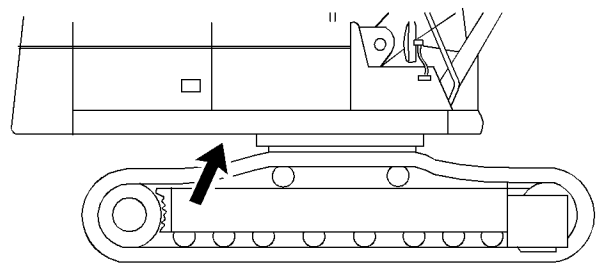

Illustration 531

g02110675

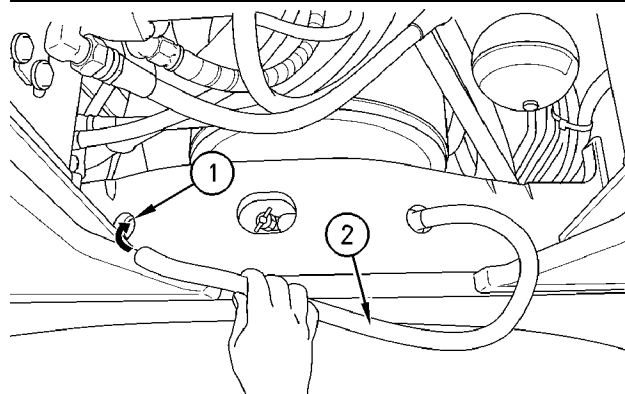

Illustration 533

g00834927

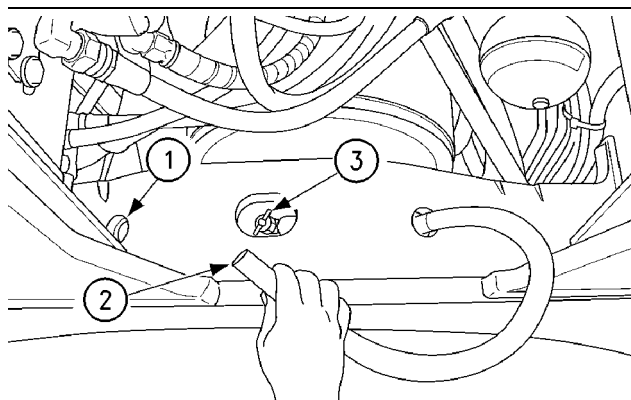

Illustration 532

g00834920

1. Remove the access cover that is located below the swing drives.

Note: Refer to Operation and Maintenance Manual, "General Hazard Information" for information that pertains to Containing Fluid Spillage.

2. Remove drain hose (2) from holder (1) on the upper frame. Face the end of the hose toward the container.
3. Use a universal joint with a socket extension to loosen the drain valve in hole (3). Drain the oil into a suitable container.

Note: Drained fluids should always be disposed of according to local regulations.

4. Tighten the drain valve. Hook the drain hose (2) to the holder (1). Make sure that the end of the hose is facing upward.

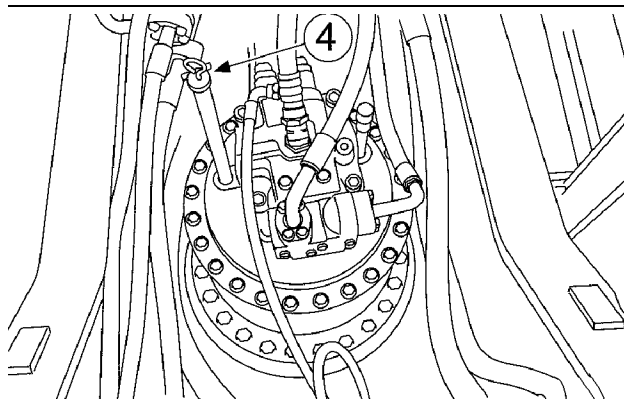

Illustration 534

g00834933

5. Remove dipstick (4).
6. Add the specified quantity of oil through the dipstick tube. See Operation and Maintenance, "Capacities (Refill)".



Illustration 535

g01049757

7. Maintain the oil level between the tip of the dipstick and the mark on the dipstick (4).
8. Check the oil that has been drained for metal chips or metal particles. Consult your Caterpillar dealer if any metal chips or metal particles are found.
9. Drained materials should always be disposed of according to local regulations.

i04067190

Swing Drive Oil Level - Check

SMCS Code: 5459-535-FLV

WARNING

Hot oil and hot components can cause personal injury. Do not allow hot oil or hot components to contact skin.

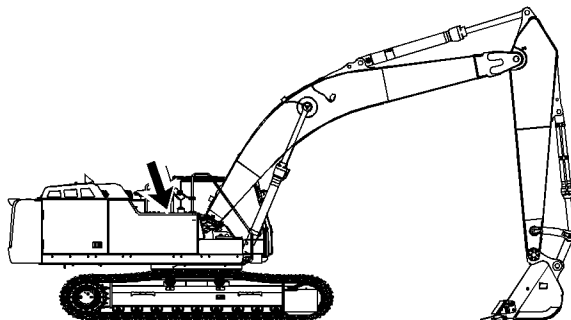

Illustration 536

g02280455

The dipstick for the swing drive oil is on the swing drive at the rear base of the boom.

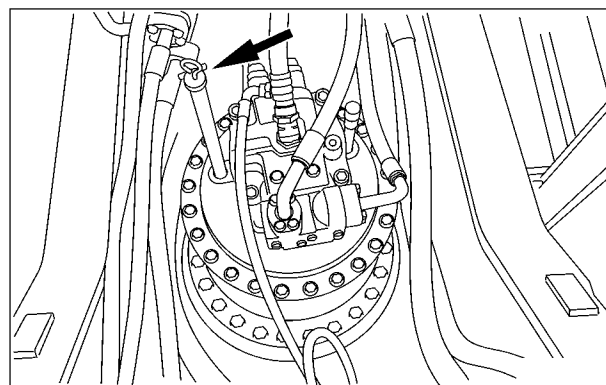

Illustration 537

g00831846

1. Remove the dipstick.



Illustration 538

g01049757

Note: Refer to Operation and Maintenance Manual, "General Hazard Information" for information that pertains to Containing Fluid Spillage.

2. Check the dipstick. Maintain the oil level between the tip of the dipstick and the mark on the dipstick. Add oil through the dipstick tube, if necessary. See Operation and Maintenance Manual, "Lubricant Viscosities".
3. Insert the dipstick.

i03754129

Swing Drive Oil Sample - Obtain

SMCS Code: 5459-008; 5459-008-OC; 5459-OC;
5459-554-OC; 7542-008

WARNING

Hot oil and hot components can cause personal injury. Do not allow hot oil or hot components to contact skin.

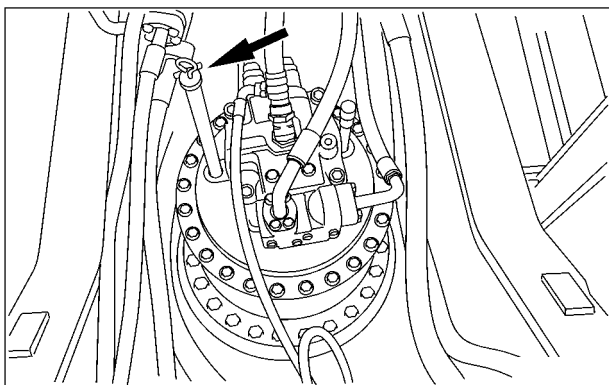

Illustration 539

g00831846

Obtain an oil sample of the swing drive oil through the opening for the dipstick. Refer to Special Publication, SEBU6250, "S-O-S Oil Analysis" for information that pertains to obtaining an oil sample from the swing drive housing. Refer to Special Publication, PEGJ0047, "How To Take A Good Oil Sample" for more information about obtaining an oil sample from the swing drive housing.

i01880393

Swing Gear - Lubricate

SMCS Code: 7063-086

Note: Refer to Operation and Maintenance Manual, "Lubricant Viscosities" for more information on the types of grease to use. Refer to Special Publication, SEBU6250, "Caterpillar Machine Fluids Recommendations" for more information on grease.

NOTICE

Improper lubrication can cause damage to machine components.

To avoid damage, make sure that the proper amount of grease is applied to the swing drive.

When the amount of grease in the compartment becomes too large, the agitation loss becomes large, thereby accelerating grease deterioration.

Grease deterioration can cause damage to the pinion gear of the swing drive and swing internal gear.

Not enough grease will result in poor gear lubrication.

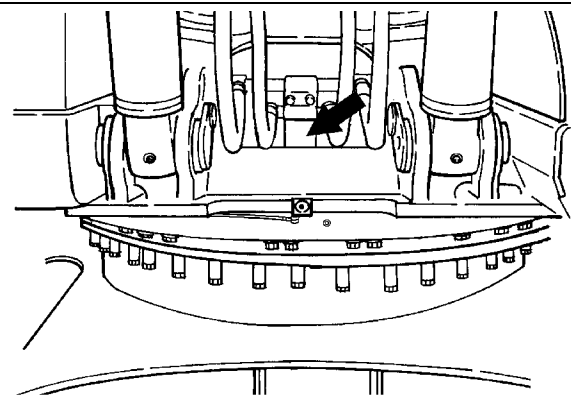

Illustration 540

g00688052

Remove the inspection cover that is located near the boom base. Inspect the grease.

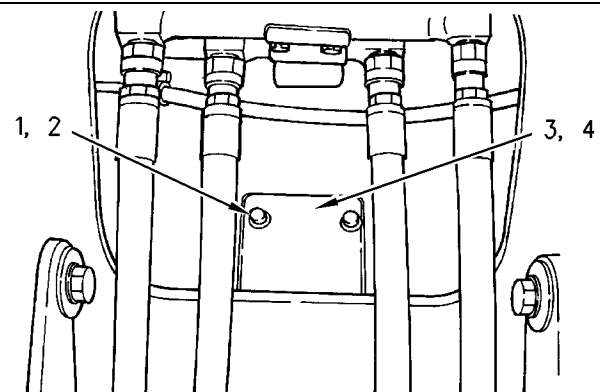

Illustration 541

g00688056

- (1) Bolts
- (2) Washers
- (3) Cover
- (4) Gasket

1. Remove bolts (1) and washers (2). Remove cover (3) and gasket (4).

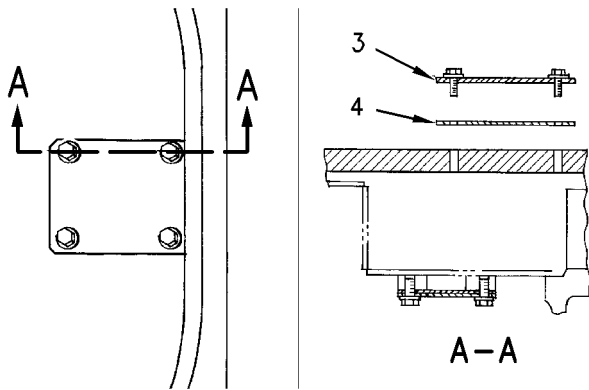

Illustration 542

g00688058

- (3) Cover
(4) Gasket

2. Inspect gasket (4). Replace the gasket if damage is evident.
3. Check the level of the grease. The grease should be evenly distributed on the floor of the pan.

Refer to Operation and Maintenance Manual, "Capacities (Refill)" for the size of the pan.

Add grease, as needed. Remove grease, as needed. Too much grease will result in the deterioration of the grease because of excessive movement of the grease. Too little grease will result in poor lubrication of the swing gear.

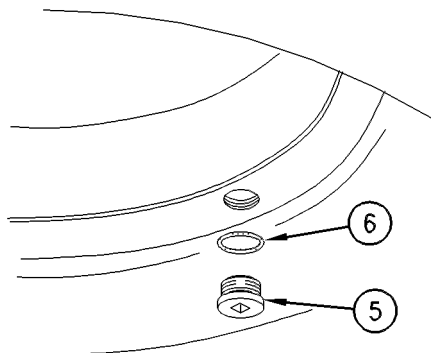

Illustration 543

g00101653

- (5) Plug
(6) O-ring

4. Check for contamination and for discolored grease.
5. If the grease is contaminated or discolored with water, change the grease. Remove plug (5) in order to allow the water to drain. When you reinstall plug (5), inspect O-ring (6). Replace the O-ring if damage is evident.

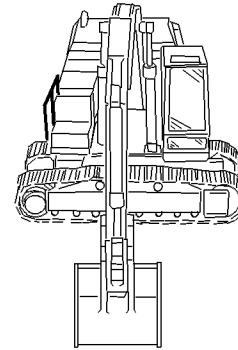

Illustration 544

g00101644

6. Raise the boom and turn the upper structure by 1/4 turn. Lower the bucket to the ground.
7. Repeat Step 6 at every 1/4 turn in four places. Add grease, as needed.
8. Install gasket (4), cover (3), washers (2), and bolts (1).

i02279232

Track Adjustment - Adjust

SMCS Code: 4170-025

WARNING

Personal injury or death can result from grease under pressure.

Grease coming out of the relief valve under pressure can penetrate the body causing injury or death.

Do not watch the relief valve to see if grease is escaping. Watch the track or track adjustment cylinder to see if the track is being loosened.

Loosen the relief valve one turn only.

If track does not loosen, close the relief valve and contact your Caterpillar dealer.

NOTICE

Keeping the track properly adjusted will increase the service life of the track and drive components.

Note: The track tension must be adjusted according to the current operating conditions. Keep the track as slack as possible if the soil is heavy.

Measuring Track Tension

1. Operate the machine in the direction of the idlers.

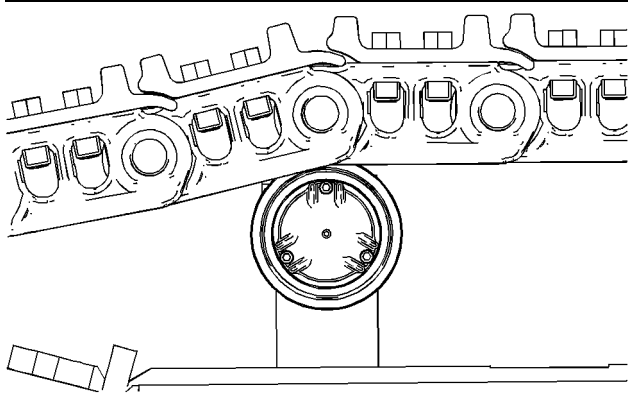

Illustration 545

g01103855

2. Stop with one track pin directly over the front carrier roller. Park the machine and turn off the engine.

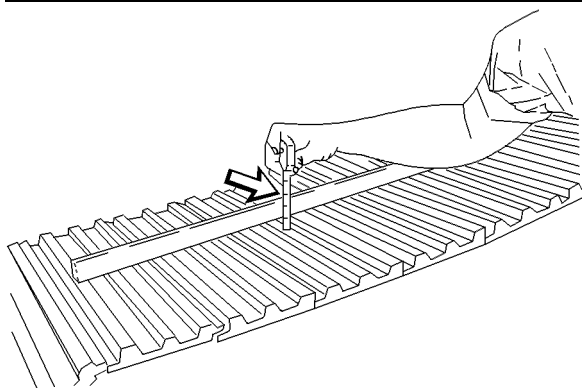

Illustration 546

g00101752

3. Place a straight edge on top of the track grousers between the front carrier roller and the idler. The straight edge should be long enough to reach from the front carrier roller to the idler.
4. Measure the maximum amount of sag in the track. The sag is measured from the highest point of the track grouser to the bottom of the straight edge. A track that is properly adjusted will have a sag of 40.0 to 55.0 mm (1.57 to 2.17 inch).
5. If the track is too tight, or if the track is too loose, adjust the track tension according to the appropriate procedure below.

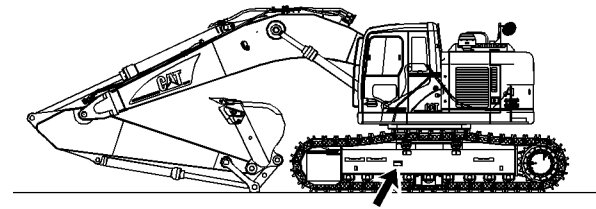

Illustration 547

g01141874

The track adjuster is located on the track frame.

Tightening the Track

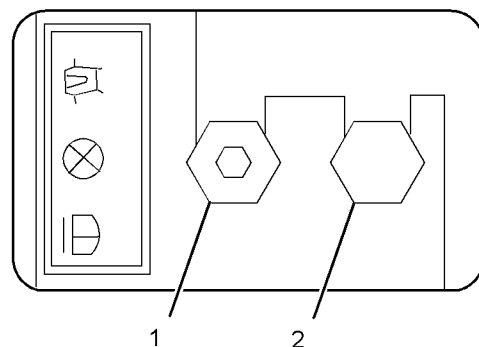

Illustration 548

g01091134

- (1) Grease fitting
- (2) Relief valve

Wipe the fitting before you add grease.

1. Add grease through grease fitting (1) until the correct track tension is reached.
2. Operate the machine back and forth in order to equalize the pressure.

3. Check the amount of sag. Adjust the track, as needed.

Loosening the Track

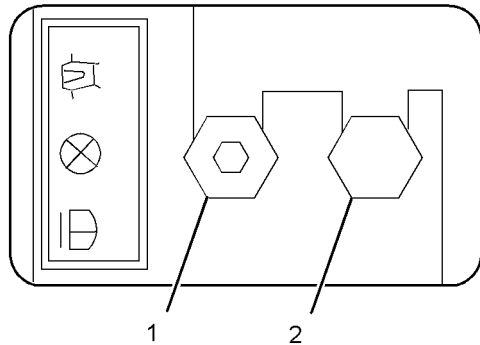

Illustration 549

g01091134

- (1) Grease fitting
(2) Relief valve

1. Loosen relief valve (2) carefully until the track begins to loosen. One turn should be the maximum.
2. Tighten relief valve (2) to 34 ± 5 N·m (25 ± 4 lb ft) when the desired track tension is reached.
3. Operate the machine back and forth in order to equalize the pressure.
4. Check the amount of sag. Adjust the track, as needed.

If the correct adjustment cannot be achieved, consult your Caterpillar Dealer.

i01590290

Track Adjustment - Inspect

SMCS Code: 4170-040

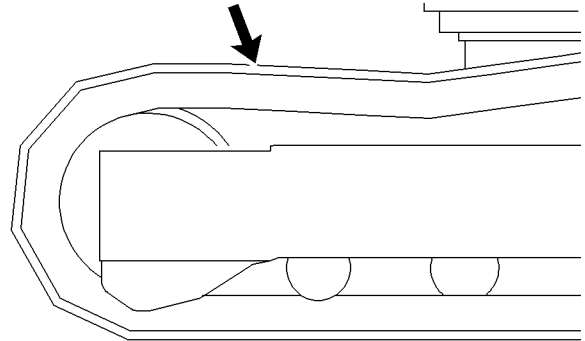

Illustration 550

g00824541

Check the track adjustment. Check the track for wear and for excessive dirt buildup.

If the track appears to be too tight or too loose, refer to Operation and Maintenance Manual, "Track Adjustment - Adjust".

i04571216

Travel Alarm - Test (If Equipped)

SMCS Code: 7429-081

Move the machine in order to test the travel alarm.

1. Start the engine. Move the hydraulic lockout control to the UNLOCKED position.
2. Raise the work tool in order to avoid any obstacles. Make sure that there is adequate overhead clearance.

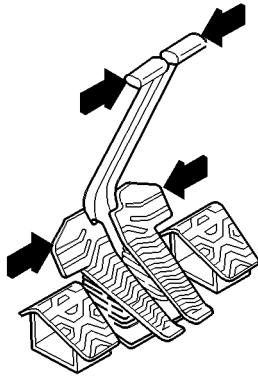

Illustration 551

g00560313

3. Use the travel levers or the travel pedals to move the machine forward. The travel alarm should sound.
4. Release the travel levers and the travel pedals in order to stop the machine.
5. Use the travel levers and the travel pedals to move the machine backward. The travel alarm should sound.

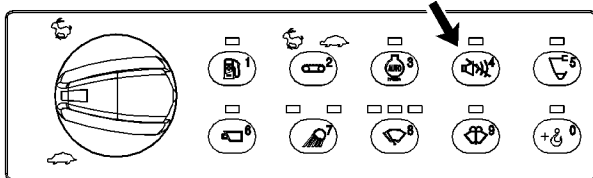

Illustration 552

g02730938

6. Push the alarm cancel switch. The travel alarm should shut off.
7. Stop the machine. Lower the work tool to the ground. Move the hydraulic lockout control to the LOCKED position. Stop the engine.

i03934011

Undercarriage - Check

SMCS Code: 4150-535

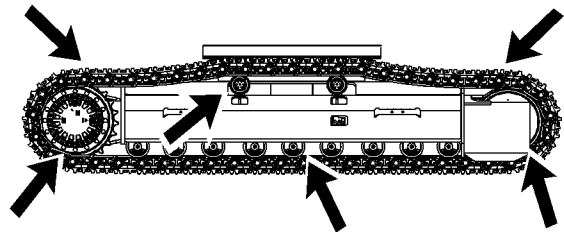

Illustration 553

g02154815

1. Check the carrier rollers, the track rollers, and the idler wheels for possible leakage.
2. Check the surface of the track, the carrier rollers, the track rollers, the idler wheels, the track shoes, and the drive sprockets. Look for signs of wear and loose mounting bolts.
3. Listen for any abnormal noises while you are moving slowly in an open area.
4. If abnormal wear exists or abnormal noises or leaks are found, consult your Caterpillar dealer.

i05976530

Window Washer Reservoir - Fill

SMCS Code: 7306-544-KE

NOTICE

When operating in freezing temperatures, use Caterpillar or any commercially available nonfreezing window washer solvent.

i03898951

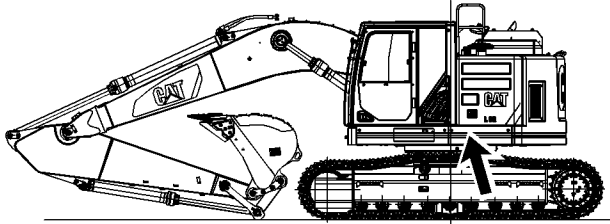

Illustration 554

g03744820

1. The window washer reservoir is located on the left side of the machine.
2. Open the access door on the left side of the machine.

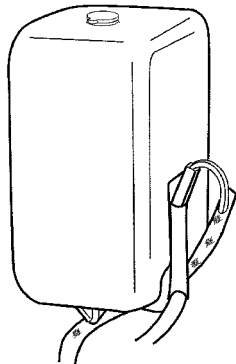

Illustration 555

g00786695

3. Remove the filler cap.
4. Fill the window washer reservoir with washer fluid through the filler opening.
5. Install the filler cap.
6. Close the access door.

i01258249

Window Wiper - Inspect/Replace

SMCS Code: 7305-510; 7305-040

Inspect the condition of the wiper blades. Replace the wiper blades if the wiper blades are worn or damaged or if streaking occurs.

Window - Check

SMCS Code: 7310-535

Check the polycarbonate windows of the cab for the following conditions.

- yellow or haze
- scratches on either side of the window that can be felt with a fingernail
- small cracks that come from the edges or mounting holes
- contact with fluids that result in haze or clouds on the window such as brake fluid

When any of the above conditions exist, contact your Caterpillar dealer for replacement.

i03912371

Windows - Clean

SMCS Code: 7310-070; 7340-070

Clean the outside of the windows from the ground, unless handholds are available.

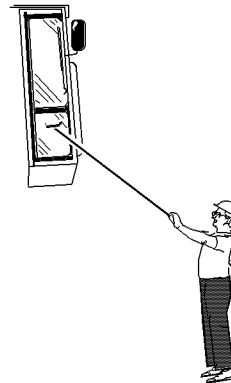

Illustration 556

g00566124

Typical example

Cleaning Methods

Aircraft Window Cleaner

Apply the cleaner with a soft cloth. Rub the window with moderate pressure until all the dirt is removed. Allow the cleaner to dry. Wipe off the cleaner with a clean soft cloth.

Soap and Water

Use a clean sponge or a soft cloth. Wash the windows with a mild soap or with a mild detergent. Also use plenty of lukewarm water. Rinse the windows thoroughly. Dry the windows with a moist chamois or with a moist cellulose sponge.

Stubborn Dirt and Grease

Wash the windows with a good grade of naphtha, of isopropyl alcohol, or of Butyl Cellosolve. Then, wash the windows with soap and with water.

Polycarbonate Windows (If equipped)

Wash polycarbonate windows with a mild soap or detergent. Never use a cleaning solvent on polycarbonate windows.

Wash polycarbonate windows with warm water and a soft sponge, or damp cloth. Never use a dry cloth or paper towels on polycarbonate windows.

Rinse the windows with a sufficient amount of clean water.

Warranty Section

Warranty Information

i06044323

Emissions Warranty Information

SMCS Code: 1000

The certifying engine manufacturer warrants to the ultimate purchaser and each subsequent purchaser that:

1. New non-road diesel engines and stationary diesel engines less than 10 liters per cylinder (including Tier 1 and Tier 2 marine engines < 37 kW, but excluding locomotive and other marine engines) operated and serviced in the United States and Canada, including all parts of their emission control systems (“emission related components”), are:
 - a. Designed, built, and equipped so as to conform, at the time of sale, with applicable emission standards prescribed by the United States Environmental Protection Agency (EPA) by way of regulation.
 - b. Free from defects in materials and workmanship in emission-related components that can cause the engine to fail to conform to applicable emission standards for the warranty period.
2. New non-road diesel engines (including Tier 1 and Tier 2 marine propulsion engines < 37 kW and Tier 1 through Tier 4 marine auxiliary engines < 37 kW, but excluding locomotive and other marine engines) operated and serviced in the state of California, including all parts of their emission control systems (“emission related components”), are:
 - a. Designed, built, and equipped so as to conform, at the time of sale, to all applicable regulations adopted by the California Air Resources Board (ARB).
 - b. Free from defects in materials and workmanship which cause the failure of an emission-related component to be identical in all material respects to the component as described in the engine manufacturer's application for certification for the warranty period.

3. New non-road diesel engines installed in construction machines conforming to the South Korean regulations for construction machines manufactured after January 1, 2015, and operated and serviced in South Korea, including all parts of their emission control systems (“emission related components”), are:
 - a. Designed, built, and equipped so as to conform, at the time of sale, with applicable emission standards prescribed in the Enforcement Rule of the Clean Air Conservation Act promulgated by South Korea MOE.
 - b. Free from defects in materials and workmanship in emission-related components that can cause the engine to fail to conform to applicable emission standards for the warranty period.

The aftertreatment system can be expected to function properly for the lifetime of the engine (emissions durability period) subject to prescribed maintenance requirements being followed.

A detailed explanation of the Emission Control Warranty that is applicable to new non-road and stationary diesel engines, including the components covered and the warranty period, is found in a supplemental Special Publication. Consult your authorized Cat dealer to determine if your engine is subject to an Emission Control Warranty and to obtain a copy of the applicable Special Publication.

Reference Information Section

Reference Materials

i07422648

Reference Material

SMCS Code: 1000; 7000

Additional literature regarding your product may be purchased from your local Cat dealer or by visiting publications.cat.com. Use the product name, sales model, and serial number to obtain the correct information for your product.

publications.cat.com

i01480753

Decommissioning and Disposal

SMCS Code: 1000; 7000

Disposal of your machine will vary on local regulations. Consult the nearest Caterpillar Dealer for additional information on disposal.

Index

A

Access Door and Cover Locations.....	220
Engine Hood	220
Left Access Door	221
Right Access Door.....	221
Additional Messages	18
Air Conditioner/Cab Heater Filter (Recirculation) - Inspect/Replace	242
Air Conditioning and Heating Control.....	146
English Versus Metric Toggle	148
Alternate Exit	101
FOGS (If Equipped).....	102
Front Window (If Equipped).....	101
Right Side Window	101
Roof Hatch (If Equipped).....	101–102

B

Battery - Clean.....	242
Battery - Recycle	242
Battery Disconnect Switch	120
Battery Hold-Down - Tighten.....	242
Battery or Battery Cable - Inspect/Replace...	242
Before Operation.....	36, 99
Before Starting Engine	33
Belt - Inspect/Adjust/Replace	243
Blade Control (If Equipped).....	159
Blade Operation (If Equipped).....	202
Boom and Stick Linkage - Lubricate	243
Boom, Stick and Bucket Operation	176
Digging.....	176
Lifting Objects	177
Machines that are Equipped with a Long Reach Configuration	179
Boom/Stick/Bucket Combinations.....	51
ANZ.....	51
EAME.....	52
NACD.....	54
Bucket - Remove and Install	191
Bolted Flag.....	193
Captured Flag	191
Crossbolt.....	195
Bucket Linkage - Inspect/Adjust.....	244
Bucket Linkage - Lubricate.....	245
Installation of the Bucket	246
Bucket Tips - Inspect/Replace	249, 252
Bucket Tips	252
Installation.....	250
Removal.....	250

Side Cutters	254
Side Cutters (If Equipped)	250
Side Protectors (If Equipped)	251, 254
Bucket Tips - Inspect/Replace (Drive- through System)	246
Bucket Tips	246
Side Cutters (If Equipped)	248
Side Protectors (If Equipped)	248
Burn Prevention.....	28
Batteries.....	28
Coolant	28
Oils.....	28

C

Cab Air Filter (Fresh Air) - Clean/Replace	255
Cab Door	152
Side Window.....	152
Cab Door Latch - Inspect/Adjust/Replace.....	256
Cab Door Latch Adjust.....	256
Cab Door Latch Inspect.....	256
Cab Door Latch Replace	257
Cab Door Stop Adjust.....	256
Camera.....	124
Rear View Camera (If Equipped).....	124
Side View Camera (If Equipped)	124
Camera - Clean (If Equipped)	257
Capacities (Refill)	230
Circuit Breakers - Reset	258
Condenser (Refrigerant) - Clean.....	259
Cooling System Coolant (ELC) - Change	259
Cooling System Coolant Extender (ELC) - Add	261
Cooling System Coolant Level - Check.....	262
Cooling System Coolant Sample (Level 1) - Obtain	263
Cooling System Coolant Sample (Level 2) - Obtain	264
Crushing Prevention and Cutting Prevention..	27

D

Daily Inspection	99
Declaration of Conformity.....	98
Decommissioning and Disposal.....	324
DEF Filler Screen - Clean (Emission Related Component)	264
DEF Manifold Filters - Replace (Emission Related Component)	265

Demolition	40	Ether	32
Diesel Exhaust Fluid - Fill	269	Fire Extinguisher	32
Diesel Exhaust Fluid Filter - Replace	267	General	29
Diesel Exhaust Fluid Injector - Replace	268	Lines, Tubes, and Hoses	31
E		Regeneration	29
Electrical Storm Injury Prevention	33	Wiring	31
Emissions Certification Film	97	Fire Safety	32
Emissions Warranty Information	323	Foreword	5
Engine Air Filter Primary Element - Clean/ Replace	270	California Proposition 65 Warning	5
Cleaning Primary Air Filter Elements	271	Certified Engine Maintenance	6
Inspecting the Primary Air Filter Elements	272	Literature Information	5
Engine Air Filter Secondary Element - Replace	273	Machine Capacity	6
Engine and Machine Warm-Up	165	Maintenance	5
Hydraulic System	165	Operation	5
Improve Cold Weather Performance	166	Product Identification Number	6
Engine Oil and Filter - Change	274	Safety	5
Procedure for Changing Engine Oil and Filter	275	Freezing Conditions	203
Selection of the Oil Change Interval	274	Frozen Ground Conditions	168
Engine Oil Level - Check	273	Fuel Lift Pump Strainer - Replace	280
Engine Oil Sample - Obtain	274	Fuel System - Prime	281
Engine Starting	36, 164	Fuel System Primary Filter (Water Separator) Element - Replace	282
Engine Starting (Alternate Methods)	217	Fuel System Secondary Filter - Replace	283
Engine Starting with Auxiliary Start Receptacle	218	Fuel System Water Separator - Drain	284
Engine Starting with Jump Start Cables	217	Fuel Tank Cap Filter - Replace	284
Engine Stopping	40	Fuel Tank Shutoff and Drain Control	163
Equipment Lowering with Engine Stopped 168		Fuel Tank Strainer - Clean	284
Blade (If Equipped)	170	Fuel Tank Water and Sediment - Drain	285
Machine with a Boom Lowering Control Valve	170	Fumes Disposal Filter Element - Replace	285
Machine without a Boom Lowering Control Valve	168	Fuses - Replace	286
Pressure Release of Auxiliary Lines	170	Relays	287
Ether Starting Aid Cylinder - Replace (If Equipped)	277	G	
F		General Hazard Information	25
Final Drive Oil - Change	278	Containing Fluid Spillage	26
Final Drive Oil Level - Check	279	Dispose of Waste Properly	27
Final Drive Oil Sample - Obtain	280	Fluid Penetration	26
Final Drive Ring Gear Removal	215	Inhalation	27
Fire Extinguisher Location	33	Pressurized Air and Water	26
Fire Prevention and Explosion Prevention	29	Trapped Pressure	26
Battery and Battery Cables	30	General Information	47
		Guards	45
		Guards (Operator Protection) Other Guards (If Equipped)	46
		Rollover Protective Structure (ROPS), Falling Object Protective Structure (FOPS) or Tip Over Protection Structure (TOPS)	45

H

High Intensity Discharge Lamp (HID) - Replace (If Equipped).....	288
Hydraulic System Oil - Change.....	288, 293
Cat HYDO Advanced 10 Oil Change Interval	288
Cat HYDO Advanced Oil Change Interval	293
Procedure to Change the Hydraulic Oil....	288, 293
Hydraulic System Oil Filter (Case Drain) - Replace	297
Hydraulic System Oil Filter (Pilot) - Replace	299
Hydraulic System Oil Filter (Return) - Replace	301
Hydraulic System Oil Level - Check.....	306
Hydraulic System Oil Sample - Obtain.....	308

I

Identification Information	96
Important Safety Information.....	2
Indicators and Gauges - Test	308

J

Joystick Controls	154
Joystick Controls (Medium Pressure (If Equipped)).....	153
Rotating Tool Control	154
Joystick Controls Alternate Patterns	160
Changing Machine Control Pattern By Four- Way Valve (If Equipped)	160
Changing Machine Control Pattern by Two- Way Valve (If Equipped)	161

L

Leaving the Machine	205
Lifting and Tying Down the Machine	210
Lifting the machine.....	211
Lifting the Machine Segments	213
Tying Down the Machine	211
Lifting Capacities.....	58
335F LC BLADE UP 6150 mm (242 inch) Reach Boom with a 2650 mm (104 inch) Stick and 7700 kg (16975 lb) Counterweight.....	83
335F LC BLADE UP 6150 mm (242 inch) Reach Boom with a 3200 mm (126 inch)	

Stick and 7700 kg (16975 lb) Counterweight.....	77
335F LCR 6150 mm (242 inch)Reach Boom with a 2650 mm (104 inch)Stick and 7700 kg (16975 lb) Counterweight.....	65
335F LCR 6150 mm (242 inch)Reach Boom with a 3750 mm (148 inch)Stick and 7700 kg (16975 lb) Counterweight.....	71
335F LCR6150 mm (242 inch)Reach Boom with a 3200 mm (126 inch)Stick and 7700 kg (16975 lb) Counterweight.....	59
335F LCRBLADE UP 6150 mm (242 inch) Reach Boom with a 3750 mm (148 inch) Stick and 7700 kg (16975 lb) Counterweight.....	89
Symbols Found in the Lifting Capacity Charts	59
Lifting Objects.....	40
Lubricant Viscosities (Fluids Recommendations)	222
Biodiesel	228
Coolant Information	229
Diesel Exhaust Fluid	226
Diesel Fuel Recommendations	225
Engine Oil	222
Fuel Additives	228
General Information for Lubricants.....	222
Hydraulic Systems.....	223
Other Fluid Applications	224
Selecting the Viscosity.....	222
Special Lubricants	225
Lubricant Viscosities and Refill Capacities ...	222

M

Machine Operation	101
Machine Security System (If Equipped).....	123
Basic Operation	123
Operation Section.....	123
Regulatory Compliance Section	124
Security Management.....	123
Maintenance Access	220
Maintenance Interval Schedule.....	239
Every 10 000 Service Hours	241
Every 10 Service Hours or Daily.....	239
Every 100 Service Hours of Continuous Hammer Use	240
Every 1000 Service Hours of Partial Hammer Use (50% of Service Hours)	241
Every 1000 Service Hours or 6 Months.....	240
Every 12 000 Service Hours or 6 Years.....	241

Every 1500 Service Hours or 9 Months.....	241	Mounting and Dismounting	99
Every 2000 Service Hours or 1 Year	241	Alternate Exit	99
Every 250 Service Hours	240	Machine Access System Specifications	99
Every 250 Service Hours of Continuous Hammer Use	240	o	
Every 250 Service Hours of Partial Hammer Use (50% of Service Hours)	240	Oil Filter (Hydraulic Hammer) - Replace	309
Every 250 Service Hours or Monthly	240	Operating Technique Information	172
Every 3 Years After Date of Installation or Every 5 Years After Date of Manufacture	241	Operating Precaution.....	174
Every 3000 Service Hours or 18 Months... ..	241	Restricted Operation.....	172
Every 500 Service Hours	240	Operating Techniques	172
Every 500 Service Hours of Partial Hammer Use (50% of Service Hours)	240	Operation.....	37, 167
Every 500 Service Hours or 3 Months.....	240	Limiting Conditions and Criteria	37
Every 5000 Service Hours	241	Machine Operating Temperature Range	37
Every 600 Service Hours of Continuous Hammer Use	240	Machine Operation	39
Every 6000 Service Hours or 3 Years	241	Machine Operation when the Machine is not Completely Assembled	40
Every Year	241	Operation Information	167
Initial 250 Service Hours.....	240	Lifting Objects	168
Initial 500 Hours (for New Systems, Refilled Systems, and Converted Systems)	240	Operation Section.....	99
When Required.....	239	Operator Controls.....	110
Maintenance Section.....	220	Air Conditioning and Heating Control (10).....	115
Maintenance Support	232	Automatic Engine Speed Control (15).....	116
Mirror (If Equipped)	148	Cat Grade Control (If Equipped).....	110
Mirror Adjustment	149	Cat Grade Control Monitor (5) (if equipped)	114
Mirror Installation	210	Engine Speed Control (12)	116
Monitoring System.....	125	Engine Start Switch (7)	115
Action Lamp (1)	126	Fine Swing Control (28B)	120
Camera View (4) (If Equipped)	127	Heavy Lift Control (18).....	117
Changing the Password	139	Hydraulic Lockout Control (1).....	112
Clock Bar (2).....	126	Joystick Controls (6)	114
Current Totals	138	Light Switch (21)	118
Display Setting.....	133	Lower Window Wiper and Window Washer (26-27) (If Equipped).....	119
Engine Shutdown Setting	139	Monitor (4)	114
Gauges (3).....	126	Operator Controls	111
Key Pad (7).....	127	Operators Seat (9).....	115
Language Selection.....	136	Overload Warning Device (29)	120
Machine Warnings.....	128	Power Mode (13)	116
Main Menu	133	Quick Coupler Control (23).....	119
Maintenance Intervals	137	Radio (11)	116
Multi-information Area (6)	127	Radio Mute Switch (25)	119
Other Messages	132	Rear/Side View Camera (22).....	119
Performance	136	Service Hour Meter (3)	114
Power Mode Setting	136	Service Port	120
Prestart Monitoring Function	128	SmartBoom Control (28A)	120
Selecting the Work Tool	138	Travel Alarm Cancel Switch (16).....	117
Warning Display Area (5).....	127	Travel Control (2).....	113
		Travel Speed Control (14)	116

Window Wiper and Window Washer (19-20).....	117
Work Tool Control (17).....	117
Operator Station.....	45

P

Parking.....	41, 203
Plate Locations and Film Locations.....	96
Electromagnetic Emissions.....	96
Engine Serial Number.....	97
Product Identification Number (PIN) and CE Plate.....	96
Sound Certification Film.....	97
Power Receptacle (If Equipped).....	123
Product Information Section.....	47
Product Link.....	121
Data Broadcasts.....	122
Operation in a Blast Site for Product Link Radios.....	122

Q

Quick Coupler Operation (Circuit for Universal Coupler (If Equipped)).....	188
Operation.....	188
Releasing the Work Tool.....	190
Resetting the Quick Coupler Controls.....	188
Securing the Work Tool.....	188
Quick Coupler Operation (Hydraulic Pin Grabber Quick Coupler (If Equipped)).....	180
General Operation.....	180
Quick Coupler Operation.....	181

R

Radiator, Aftercooler and Oil Cooler Cores - Clean.....	311
Radio (If Equipped).....	141, 144
Loss of Memory.....	143
Presetting Radio Stations.....	142
Radio Reception.....	143
Radio Reception Area.....	146
Scan and Auto Memory.....	143
Receiver Dryer (Refrigerant) - Replace.....	311
Reference Information Section.....	324
Reference Material.....	324
Reference Materials.....	324
Restricted Visibility.....	34
Rollover Protective Structure (ROPS) - Inspect.....	312
Roof Hatch.....	151

S

S·O·S Information.....	231
Safety Messages.....	7
Aerosol Starting Aid (14).....	15
Crushing Hazard (10).....	13
Crushing Hazard (12).....	14
Crushing Hazard (19).....	17
Crushing Hazard (2).....	10
Crushing Hazard (22).....	17
Crushing Hazard (6).....	12
Crushing Hazard (9).....	13
Crushing Injury (4).....	11
Do Not Operate (1).....	10
Do Not Weld or Drill on ROPS (7).....	12
Electrical Power Lines (5).....	11
High Pressure Cylinder (16).....	16
High Pressure Gas (17).....	16
Hot Surface (20).....	17
Jump Start Cables (15).....	15
Lifting Restriction/Counterweight Only (23).....	18
Overload Warning Device (3).....	11
Pressurized System (13).....	14
Product Link (11).....	13
Relieve Hydraulic Tank Pressure (18).....	16
Rotating Fan (21).....	17
Seat Belt (8).....	12
Safety Section.....	7
Seat.....	104
Heated Seat and Ventilated Seat (If Equipped).....	105
Seat Belt.....	105
Extension of the Seat Belt.....	107
Seat Belt Adjustment for Non-Retractable Seat Belts.....	105
Seat Belt Adjustment for Retractable Seat Belts.....	107
Seat Belt - Inspect.....	312
Seat Belt - Replace.....	312
Securing the Machine.....	207
Selective Catalytic Reduction Warning System.....	107
Definitions.....	108
Inducement Strategy for DEF Level.....	108
Inducement Strategy for DEF Quality, Tampering, SCR System Fault, and Impeded EGR.....	109
Service Interval Chart.....	232
Severe Service Application.....	237
Improper Maintenance Procedures (Maintenance Procedures Which May	

Contribute to a Severe Service Application)	237	Loosening the Track	319
Severe Environmental Factors	237	Measuring Track Tension	318
Severe Operating Conditions	237	Tightening the Track	318
Shipping the Machine	207	Track Adjustment - Inspect.....	319
Shipping a Machine that is not Completely Assembled	207	Track Information	33
Slope Operation	41	Transportation Information	207
SmartBoom Control (If Equipped).....	155	Travel Alarm - Test (If Equipped).....	319
SmartBoom Operation (If Equipped).....	179	Travel Control (Straight Travel Pedal (If Equipped)).....	152
Advantages.....	180	Travel in Water and Mud	174
Excavation and Loading	180	Procedure for Removing the Machine from Water or Mud	175
Hammering	180		
Sound Information and Vibration Information.....	42	U	
Sound Level Information.....	42	Undercarriage - Check	320
Sound Level Information for Machines in European Union Countries and in Countries that Adopt the "EU Directives"	42		
Sources.....	45	V	
"The European Union Physical Agents (Vibration) Directive 2002/44/EC"	43	Visibility Information	33
Specifications	47		
335F LCR Reach Boom	48	W	
Application/Configuration Restrictions	47	Warranty Information.....	323
Intended Use	47	Warranty Section.....	323
Specification Data.....	48	Welding on Machines and Engines with Electronic Controls	236
Working Ranges	50	Window - Check	321
Stopping the Engine	203	Window (Front).....	150
Engine Stop Control	204	Window Washer Reservoir - Fill	320
Stop the Engine if an Electrical Malfunction Occurs.....	204	Window Wiper - Inspect/Replace	321
Stopping the Machine.....	203	Windows - Clean	321
Sun Screen (If Equipped).....	151	Cleaning Methods.....	321
Swing Bearing - Lubricate	313	Polycarbonate Windows (If equipped)	322
Swing Drive Oil - Change	313	Work Tool Control (One-Way Flow) (If Equipped)	156
Swing Drive Oil Level - Check.....	315	Foot Switch	157
Swing Drive Oil Sample - Obtain.....	316	Joystick	156
Swing Gear - Lubricate.....	316	Work Tool Pedal.....	156
System Pressure Release.....	233	Work Tool Control (Two-Way Flow) (If Equipped)	158
Coolant System	233	Joystick	158
Hydraulic System.....	233	Work Tool Pedal.....	158
		Work Tool Operation (If Equipped).....	197
T		Crusher Operation (If Equipped)	200
Table of Contents	3	Hammer Operation (If Equipped)	197
Towing Information	214	Shear Operation (If Equipped)	199
Towing the Machine.....	214	Work Tools.....	36
Lightweight Towing	215		
Retrieval and Towing of Machine	215		
Track Adjustment - Adjust	317		

Product and Dealer Information

Note: For product identification plate locations, see the section "Product Identification Information" in the Operation and Maintenance Manual.

Delivery Date: _____

Product Information

Model: _____

Product Identification Number: _____

Engine Serial Number: _____

Transmission Serial Number: _____

Generator Serial Number: _____

Attachment Serial Numbers: _____

Attachment Information: _____

Customer Equipment Number: _____

Dealer Equipment Number: _____

Dealer Information

Name: _____ Branch: _____

Address: _____

Dealer Contact

Phone Number

Hours

Sales: _____

Parts: _____

Service: _____



SEBU8760
©2019 Caterpillar
All Rights Reserved

CAT, CATERPILLAR, LET'S DO THE WORK, their respective logos, "Caterpillar Yellow", the "Power Edge" and Cat "Modern Hex" trade dress as well as corporate and product identity used herein, are trademarks of Caterpillar and may not be used without permission.